

USE AND MAINTENANCE MANUAL

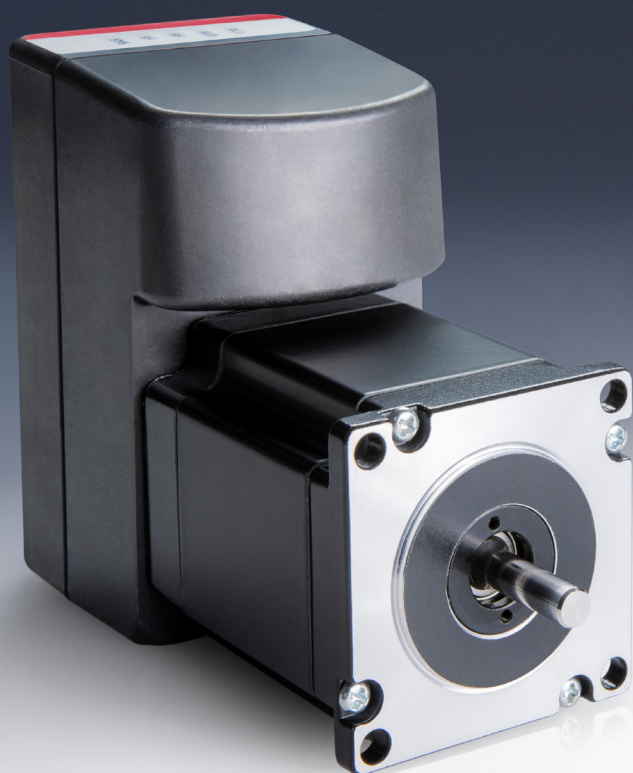

SERIE DRVI CANOPEN V 1.4



Contents

Chapter 1 General recommendations	1
1.1 Product storage and transport	2
1.2 Use	2
1.3 Limitations of use	2
1.4 Maintenance	2
1.5 Ecological Information	3
Chapter 2 Introduction	4
2.1 About this manual	4
2.2 Unit overview	4
Chapter 3 Technical data	5
3.1 Environmental conditions	5
3.2 Electrical specifications	5
3.2.1 Power supply	5
3.2.2 Wiring	6
3.2.3 Encoder	6
3.3 Electrical connections	7
3.3.1 1 - Power supply	8
3.3.2 2 - GPIO	8
3.3.3 3 - STO (NOT CERTIFIED)	10
3.3.4 4, 5 - CANopen fieldbus interface	11
3.3.5 6 - USB interface	12
3.3.6 Earth connection	12
3.4 LED indicators	12
Chapter 4 Operation Modes	14
4.1 Fieldbus Modes	14
4.1.1 Speed	14
4.1.2 Positioning	15
4.1.2.1 Relative Positioning	16
4.1.2.2 Absolute Positioning	16
4.1.3 Torque	16
4.1.4 Jog	17
4.1.5 Homing	18
4.1.5.1 Positioning homing	18
4.1.5.2 Proximity homing: negative direction	18
4.1.5.3 Proximity homing: positive direction	18
4.1.5.4 Proximity homing: negative direction + zero encoder	19
4.1.5.5 Proximity homing: positive direction + zero encoder	20

4.1.5.6	Torque homing: negative direction	20
4.1.5.7	Torque homing: positive direction	20
4.1.5.8	Torque homing: negative direction + zero encoder	21
4.1.5.9	Torque homing: positive direction + zero encoder	21
4.1.5.10	Homing offset	22
4.1.6	Other features	23
4.1.6.1	Profile software limits	23
4.1.6.2	Torque limit	23
4.2	Digital Inputs mode	23

Chapter 5 CANopen Protocol 25

5.1	Conventions	25
5.2	Configuration via EDS file	26
5.3	Object dictionary	26
5.3.1	Communication Profile - CiA 301 objects	26
5.3.2	CiA 301 objects descriptions	31
5.3.2.1	1000h Device type	31
5.3.2.2	1001h Error register	31
5.3.2.3	1002h Manufacturer status register	31
5.3.2.4	1003h Pre-defined error field	31
5.3.2.5	1005h COB-ID sync	32
5.3.2.6	1006h Communication cycle period	32
5.3.2.7	1007h Synchronous Window Length	32
5.3.2.8	1008h Manufacturer hardware name	32
5.3.2.9	1009h Manufacturer hardware version	33
5.3.2.10	100Ah Manufacturer software version	33
5.3.2.11	100Ch Guard time	33
5.3.2.12	100Dh Life time factor	33
5.3.2.13	1010h Store parameter field	33
5.3.2.14	1011h Restore parameter field	33
5.3.2.15	1014h COB-ID EMCY	33
5.3.2.16	1015h Inhibit time emergency	34
5.3.2.17	1017h Producer heartbeat time	34
5.3.2.18	1018h Identity object	34
5.3.2.19	1400h – 1407h Rx PDO communication parameter	34
5.3.2.20	1600h – 1607h Receive PDO Mapping Parameter	35
5.3.2.21	1800h – 1807h Tx PDO communication parameter	35
5.3.2.22	1A00h – 1A07h Tx PDO mapping parameter	36
5.3.2.23	1F80h NMT Start-up	36
5.3.3	Device Profile - CiA 402 objects	37
5.3.4	CiA 402 objects descriptions	37
5.3.4.1	603Fh Error code	38
5.3.4.2	6040h Controlword	38

5.3.4.3	6041h Statusword	39
5.3.4.4	6060h Mode of operation	40
5.3.4.5	6061h Mode of operation display	40
5.3.4.6	6064h Position actual value	40
5.3.4.7	606Ch Velocity actual value	40
5.3.4.8	606Fh Velocity threshold	40
5.3.4.9	6070h Velocity threshold time	41
5.3.4.10	6071h Target torque	41
5.3.4.11	6074h Torque demand value	41
5.3.4.12	6077h Torque actual value	41
5.3.4.13	607Ah Target position	41
5.3.4.14	607Ch Home offset	41
5.3.4.15	607Eh Polarity	41
5.3.4.16	6081h Profile velocity in pp-mode	42
5.3.4.17	6083h Profile acceleration	42
5.3.4.18	6083h Profile deceleration	42
5.3.4.19	6087h Torque slope	42
5.3.4.20	6091h Gear ratio	42
5.3.4.21	6098h Homing method	42
5.3.4.22	6099h Homing speeds	43
5.3.4.23	609Ah Homing acceleration	43
5.3.4.24	60FFh Target velocity	43
5.3.5	Manufacturer custom objects	43
5.3.6	Manufacturer custom objects descriptions	43
5.3.6.1	2001h Feed converter	44
5.3.6.2	2002h Input status	44
5.3.6.3	2003h Output status	44
5.3.6.4	2004h Homing ok	44
5.3.6.5	2006h Warnings	44
5.3.6.6	2010h Limits enable	44
5.3.6.7	2011h PID parameters	45
5.3.6.8	2012h Profile parameters	45
5.3.6.9	2013h Homing torque limit	45
5.3.6.10	2014h Actuator type	45
5.3.6.11	2015h Torque limit enable	45
5.4	Profile position	46
5.5	Profile velocity	47
5.6	Profile torque	47
5.7	Homing mode	48
5.8	Jog mode	50
5.9	Diagnostic behavior	51
5.9.1	Emergency Object	51
5.9.2	Errcode codes	51

5.9.3	Error dictionary objects	52
5.9.4	Warnings	52
5.10	NMT protocol description	53
5.10.1	NMT services for device control	53
5.10.1.1	NMT states machine	53
5.10.2	NMT services for device monitoring	55
5.10.2.1	Node Guarding	55
5.10.2.2	Heartbeat	56
5.11	Inputs GPIO	58
5.12	Outputs GPIO	58

Chapter 6 Uvix 59

6.1	Introduction	59
6.2	General information	60
6.3	Status information	61
6.4	Details	62
6.4.1	Variables	62
6.4.2	Alarms	62
6.4.3	Commands	65
6.5	Configuration	66
6.5.1	Actuator	66
6.5.2	Motion	66
6.5.3	Communication	67
6.5.4	GPIO	67
6.6	Commissioning	68
6.6.1	DRVI states	68
6.6.2	Mode operation parameters	69
6.6.2.1	Homing	69
6.6.2.2	Speed Profile	70
6.6.2.3	Absolute position	70
6.6.2.4	Relative position	71
6.6.2.5	Torque profile	72
6.6.3	PID	72
6.7	CANopen configuration	73
6.8	UVIX USB Gateway	74
6.8.1	Main page	74
6.8.2	Firmware update	75

General recommendations

▲ Please comply with the recommendations for safe use described in this document.

- Some hazards can only be associated with the product after it has been installed on the machine/equipment. It is the responsibility of the end user to identify these hazards and reduce the risks associated with them.
- For information regarding the reliability of the components, contact Camozzi Automation.
- Before commissioning, carefully check that the DRVI has been correctly configured with regard to the data relating to the determination of the position and movement of the device. Failure to follow these instructions can result in injury or equipment damage.
- Avoid unprotected contact with hot surfaces. Be sure that the DRVI can dissipate the heat generated during normal operation to avoid equipment damage.
- Read the information in this document carefully before using the product.
- Keep this document in a safe place and close at hand for the whole of the product's life cycle.
- Pass this document on to any subsequent owner or user.
- The instructions in this manual must be observed in conjunction with the instructions and additional information concerning the product in this manual, available from the following reference links:
 - Website www.camozzi.com
 - Camozzi general catalogue
 - Technical assistance service
- Assembly and commissioning must be performed exclusively by qualified and authorised personnel on the basis of these instructions.
- It is the responsibility of the system/machine designer to ensure the correct selection of the most suitable component according to the intended application.
- Use of appropriate personal protective equipment is recommended to minimise the risk of physical injury.
- For all situations not contemplated in this manual and in situations in which there is the risk of potential damage to property, or injury to persons or animals, contact Camozzi for advice.
- Do not make unauthorised modifications to the product. In this case, any damage or injury to property, persons or animals will be the responsibility of the user.
- It is recommended to comply with all safety regulations that apply to the product.
- Never intervene on the machine/system until you have verified that all working conditions are safe.
- Before installation or maintenance, ensure that the required safety locks are active, and then disconnect the electrical mains (if necessary) and system pressure supply, discharging all residual compressed air from the circuit and deactivating residual energy stored in springs, condensers, recipients and gravity.
- After installation or maintenance, the electrical power supply (if necessary) must be reconnected, and the regular operation of the product must be checked. In the event of a malfunction, the product

1.1 Product storage and transport

must not be used.

- Avoid covering the equipment with paint or other substances that may reduce heat dissipation.

1.1 Product storage and transport

- Adopt all measures possible to avoid accidental damage to the product during transport, and when available use the original packaging.
- Observe the specified storage temperature range of $-20 \div 70$ °C.

1.2 Use

- Make sure that the distribution network voltage and all operating conditions are within the permissible values.
- The product may only be used in observance of the specifications provided; if these requirements are not met, the product may only be used upon authorisation by Camozzi.
- Follow the indications shown on the identification plate.

1.3 Limitations of use

- Do not exceed the technical specifications given in Paragraph 2 (General characteristics and conditions of use) and in the Camozzi general catalogue.
- Do not install the product in environments where the air itself may cause hazards.
- With the exception of specific intended uses, do not use the product in environments where direct contact with corrosive gases, chemicals, salt water, water or steam may occur.

1.4 Maintenance

- Incorrectly performed maintenance operations can compromise the good working order of the product and harm surrounding persons.
- Check conditions to prevent sudden release of parts, then suspend the power supply and allow residual stresses to discharge before taking action.
- Assess the possibility of having the product serviced by a technical service centre.
- Never disassemble a live unit.
- Isolate the product electrically before maintenance.
- Always remove accessories before maintenance.
- Always wear the correct personal protective equipment as envisaged by local authorities and in compliance with current legislation.
- In the event of maintenance, or replacement of worn parts, exclusively use the original Camozzi kits and ensure that operations are performed by specialised and authorised personnel. Otherwise product approval will be rendered invalid.

1.5 Ecological Information

1.5 Ecological Information

- At the end of the product's life cycle, it is recommended to separate the materials for recycling.
- Follow the waste disposal regulations in force in your country.
- The product and relative parts all comply with the ROHS and REACH standards.

Introduction

2.1 About this manual

This manual contains the technical description of the universal integrated servomotor, designed by Camozzi Automation S.p.A.

▲ Failure to observe the information contained in this manual can result in injury or equipment damage.

Please contact Camozzi Automation S.p.A. for technical assistance.

PRODUCT SPECIFICATIONS AND DATA ARE SUBJECT TO CHANGE WITHOUT NOTICE.

© Camozzi Automation S.p.A. All rights reserved.

2.2 Unit overview

The universal integrated servomotor unit is composed of a brushless or stepper motor and a FOC (Field Oriented Control) drive.

The unit is equipped with CAN interface, that provides fieldbus communication capability with other devices, such as PLCs.

An absolute encoder allows to detect the rotor position of the motor, which is a fundamental quantity for the closed-loop control algorithms.

The power supply is divided in two sections: one for the logic stage and one for the power stage. In the following chapter are described the technical data of the drive.

Technical data

3.1 Environmental conditions

⚠ The drive installation must respect the environmental conditions specified in Table 3.1.

Table 3.1: Environmental conditions.

Condition	Value
Protection class	IP65, except motor shaft
Operating ambient temperature	-20 ... 50 °C
Storage ambient temperature	-20 ... 70 °C
Air humidity (non-condensing)	5 ... 95 %
Maximum altitude	1000 m

3.2 Electrical specifications

3.2.1 Power supply

The power supply section of the drive is divided into two parts:

- Logic (VL): provides supply to the logic stage, fieldbus interface and input-outputs.
- Main (VDC): provides supply to the power stage.

It's recommended to supply both Logic and Main power supplies by 2 different PELV (Protective Extra-Low Voltage) electronic circuits compliant to EN 60204-1

In Table 3.2 are shown the power supply operating ranges.

Table 3.2: Power supplies ranges.

Supply	Nominal value	Min/Max values
VL	24 V	24 V \pm 10%
VDC	48 V	60 V

The current absorption of the logic stage is <200mA (including auxiliary +24V output at maximum load).

⚠ During deceleration ramps the motor acts as a generator, returning a voltage on the VDC bus. The entity of such regeneration depends on the deceleration value and on the moment of inertia of the load attached to the shaft. If the voltage generated reaches the maximum VDC voltage, **the excess energy must be dissipated using an external braking system**, or changing the deceleration value otherwise the drive or the power supply could be damaged.

⚠ Install fuses for power supply cable in accordance with the electrical requirements of the equipment (be careful about inrush currents). A recommended fuse value is **T4A**.

It is also recommended to install a capacitor of 1000 uF, rated 100 V, after the output of the power supply.

3.2 Electrical specifications

⚠ The drive does not have an inrush current limitation, hence you must use the input of the power supply to turn the drive on and off. Never switch the output voltage of the power supply (hot plugging). In Figures 3.1 and 3.2 are shown the wiring examples for VDC and VL.

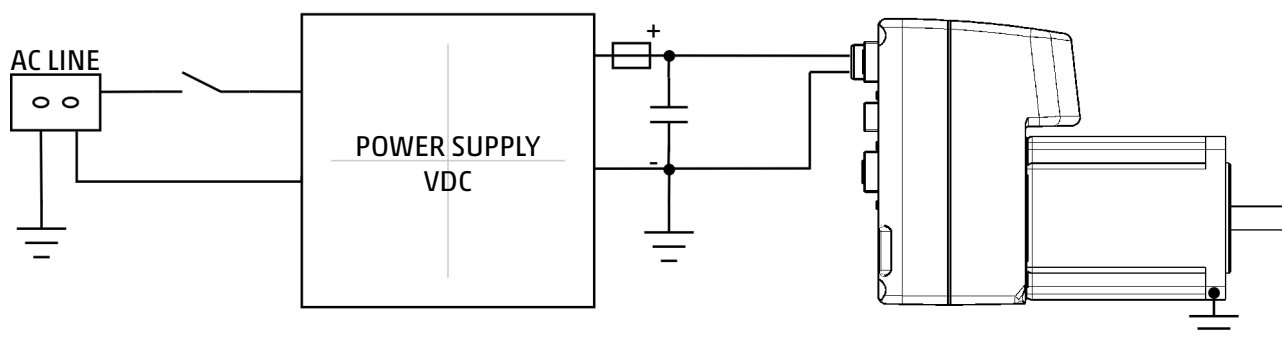

Figure 3.1: VDC wiring example.

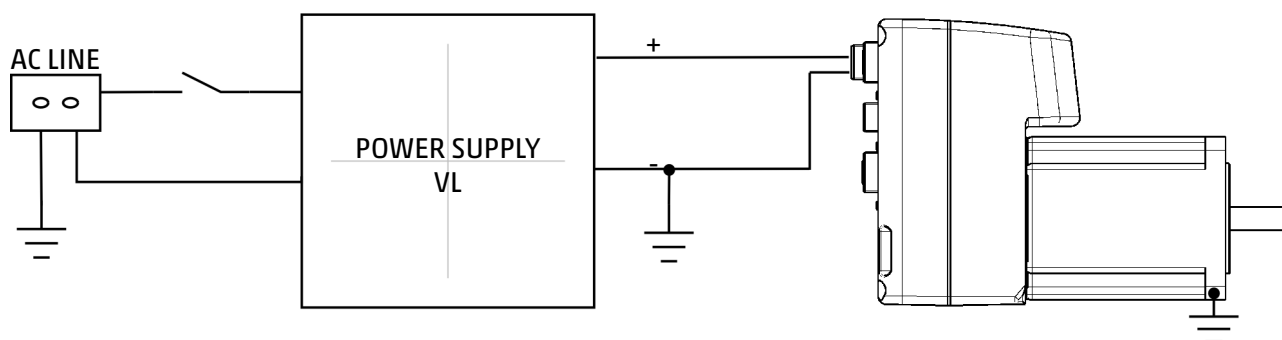

Figure 3.2: VL wiring example.

3.2.2 Wiring

The actual cable type, wire gauge, shield type, and filtering devices used are dependent on the environment, application, and system. However, we advise to use the following guidelines, when sizing the cables:

- The minimum section for the power supply cable should be AWG22 (0.75 mm²) when the motor uses the nominal current.
- For length less than 15 m, DC power supply cables can be used. Otherwise AC power supply cables should be used.
- To reduce EMC issues, use twisted and shielded cables.
- The shield should be connected to ground on the power supply side.

3.2.3 Encoder

The motor shaft position is measured using an absolute magnetic encoder.

3.3 Electrical connections

3.3 Electrical connections

In Figure 3.3 is shown the placement of the electrical connectors.



Figure 3.3: Connectors placement.

In Table 3.3 are shown the functionalities of the electrical connectors.

Table 3.3: Electrical connections.

Connection	Name	Functionality
①	PWS	Power supply
②	I/O	Inputs and outputs
③	STO	Safe Torque Off (when present) ⚠ NOT CERTIFIED
④	P1 = CAN IN	CANopen Fieldbus Interface
⑤	P2 = CAN OUT	CANopen Fieldbus Interface
⑥	-	USB (Micro-B)

NOTE: All connectors are screw type. During the wiring phase, be careful not to tighten the connectors too forcefully. The use of tools to tighten the connectors is absolutely not recommended.

3.3 Electrical connections

3.3.1 1 - Power supply

The power supply connector is a 5-poles M12 (male) A-coded. In Table 3.4 is represented the pinout of the power supply connector.

Table 3.4: 1 - Power supply connector pinout.

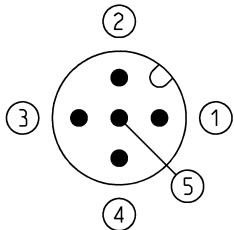
PIN	Signal	Function	Symbol
1, 5	VDC	Main power supply	
2	GND	Main power ground	
3	VL	Logic power supply	
4	GND	Main power ground	

Camozzi connector receptacle:

- CS-LF05HC, straight connector M12 5-poles male.
- CS-LF04HB, straight connector M12 5-poles male (Pin 5 is not connected).
- CS-LF05HB-D200, cable with straight M12 5-poles male connector, length 1m.
- CS-LF05HB-D500, cable with straight M12 5-poles male connector, length 5m.

⚠ The pins with GND indication are internally connected.

3.3.2 2 - GPIO

The GPIO connector is a 12-poles M12 (female) A-coded. In Table 3.5 is described the functionality of each pin and is represented the pinout of the GPIO connector.

3.3 Electrical connections

Table 3.5: 2 - GPIO connector pinout.

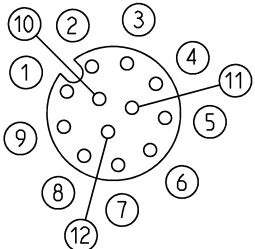
PIN	Signal	Function	Symbol
1, 2	IN1	Digital input 1 (compliant to IEC61131-2)	
3, 4	IN2	Digital input 2 (compliant to IEC61131-2)	
5, 6	OUT	Solid state relay output (PTC resettable fuse, 0.5 A hold current)	
7, 8	EXT PROXY	Digital input (24 V) for external proximity	
9, 10	PROXY HOMING	Digital input (24 V) for homing proximity	
11	GND	Digital ground	
12	+24V	Auxiliary +24 V output, max 130 mA	

NOTE: the EXT PROXY is usually used to connect the optional limit switch sensor, whilst the PROXY HOMING is used for the homing zero position

NOTE: IN1 and IN2 are general purpose inputs, typically they could be used for the jog clockwise and counter-clockwise function (see Chapter 4.2)

3.3 Electrical connections

Camozzi connector receptacle:

- CS-LM12HC, circular connector field attachable M12 12-poles (male) A-coded.
- CS-LO12HC-0025, straight connector M12 12-poles (male) and two M8 female (proximity), length 20 cm.
- CS-LM12HC-D500, straight connector M12 12-poles (male), length 5m.

Digital inputs are bidirectional: in Figure 3.4 is represented the input hardware stage.

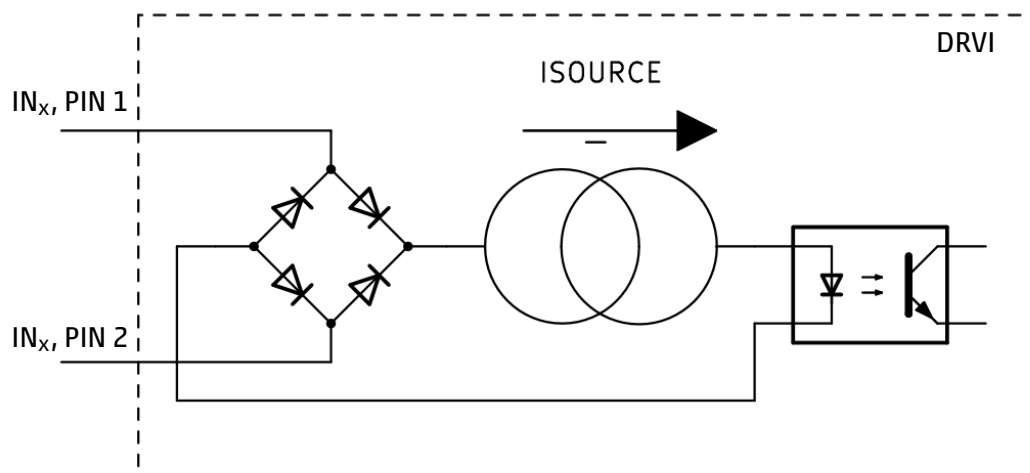

Figure 3.4: GPIO IN stage.

In Figure 3.5 is represented the output hardware stage.

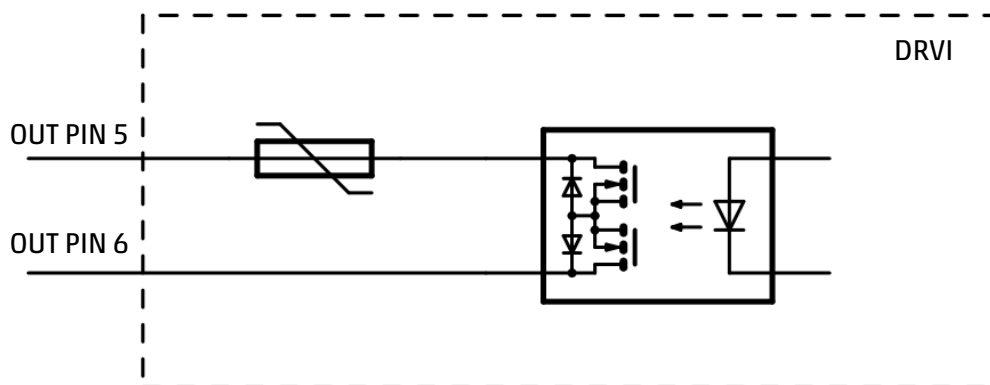

Figure 3.5: GPIO OUT stage.

3.3.3 3 - STO (NOT CERTIFIED)

⚠ STO (SAFE TORQUE OFF) FEATURE IS NOT CERTIFIED.

The STO connector (when present) is 4-poles M8 (female) A-coded. In Table 3.6 is shown the connector pinout and is displayed the STO connector. To allow the motor movement, IN1 and IN2 must be connected to +24 V, while COM1 and COM2 to GND. If IN1 or IN2 voltages are missing, the STO intervenes disconnecting the motor phases.

Camozzi connector receptacle:

- CS-DM04HB, circular connector field attachable M8 4-poles (male) A-coded.

3.3 Electrical connections

- CS-LM04HB-D500, straight connector M8 4-poles (male), length 5m.

Table 3.6: 3 - STO connector pinout.

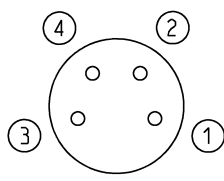
PIN	Signal	Function	Symbol
1	IN1	STO1 signal	
2	COM1	Common signal of STO1	
3	IN2	STO2 signal	
4	COM2	Common signal of STO2	

3.3.4 4, 5 - CANopen fieldbus interface

The connector for the CANopen network IN is M12A 5-pole male. In Table 3.7 is shown the connector pinout and is displayed the connector CAN IN.

Table 3.7: CAN IN connector pinout.

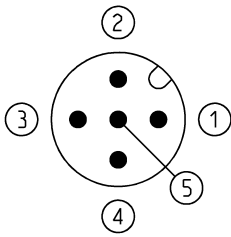
PIN	Signal	Function	Symbol
1	EARTH	Earth connection	
2	CANV+	Not connected	
3	GND	Common reference for CAN bus	
4	CANH	CANH bus line	
5	CANL	CANL bus line	

The connector for the CAN network OUT is M12A 5-pole female. In Table 3.8 is shown the connector pinout and is displayed the connector CAN OUT.

3.4 LED indicators

Table 3.8: CAN OUT connector pinout.

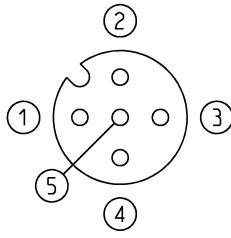
PIN	Signal	Function	Symbol
1	EARTH	Earth connection	
2	CANV+	Not connected	
3	GND	Common reference for CAN bus	
4	CANH	CANH bus line	
5	CANL	CANL bus line	

Camozzi connector receptacle:

- CS-LF05HC, straight female M12 connector for Bus-IN.
- CS-LM05HC, straight male M12 connector for Bus-OUT.
- CS-LP05H0, straight male M12 termination resistor.

Camozzi cables:

Only for BUS IN connector, is possible to use these cables:

- CS-LM05HC-D200, molded cable with straight male M12D 5-poles connector, length 2m.
- CS-LM05HC-D500, molded cable with straight male M12D 5-poles connector, length 5m.

Only for BUS OUT connector, is possible to use these cables:

- CS-LF05HB-D200, co-molded cable with straight M12A 5-poles female connector, length 2m.
- CS-LF05HB-D500, co-molded cable with straight M12A 5-poles female connector, length 5m.

3.3.5 6 - USB interface

The USB port allows the drive configuration using the UVIX interface. The USB connector is a Micro USB type B.

Camozzi connector receptacle:

- G11W-G12W-2, standard cable with micro-USB connector length 2m.

3.3.6 Earth connection

▲ It is mandatory to connect the motor flange to earth (\perp). The GND must be connected to the earth, using a common central point, near to the power supply.

3.4 LED indicators

The integrated drive provides visual information using LED indicators. Their functionality is shown in Table 3.9, and their detailed description is given in Table 3.10.

Table 3.9: LED indicators functionality.

Name	Color	Function	Indicator
ERR	Red	CAN bus errors	
RUN	Green	CAN status	
SYS	Red / green (bicolor)	Drive system LED	

Table 3.10: LED indicators description.

Name	Color	State	Description
ERR	●	OFF	No CAN bus errors
	☀	1ON-10FF BLINK	CAN bus invalid, LSS
	☀	1ON-50FF BLINK	CAN bus warning
	☀	2ON-50FF BLINK	CAN bus NMT error
	☀	3ON-50FF BLINK	CAN bus SYNC error
	☀	4ON-50FF BLINK	CAN bus Event error
RUN	○	OFF	No CAN diagnostic
	☀	1ON-50FF BLINK	CAN Stopped status
	☀	1ON-10FF BLINK	CAN Pre-operational status
SYS	●	ON	CAN Operational status
	☀	1 BLINK	Servo OFF
	☀	2 BLINK	Servo ON
	☀	1 BLINK	VL / VDC UVLO or OVLO error
	☀	2 BLINK	Over temperature or I ² T error
	☀	3 BLINK	STO error
	☀	4 BLINK	Homing error / internal error

Operation Modes

This Chapter describes the possible operation modes of the drive that could be fieldbus modes or digital inputs mode

4.1 Fieldbus Modes

4.1.1 Speed

This drive mode operation requires a specific target speed, acceleration and deceleration: once the velocity target is set, the motor accelerates until the target speed is reached and then maintains the required velocity until a new request is made. The speed profile executed is trapezoidal.

In Figure 4.1 is shown an example of speed profile with the following parameters:

- Target acceleration = 60 RPM / s
- Target deceleration = 60 RPM / s
- Initial speed = 0 RPM
- Target speed = 60 RPM (target given at $t = 0$ s)
- Target speed = 0 RPM (target given at $t = 2$ s)

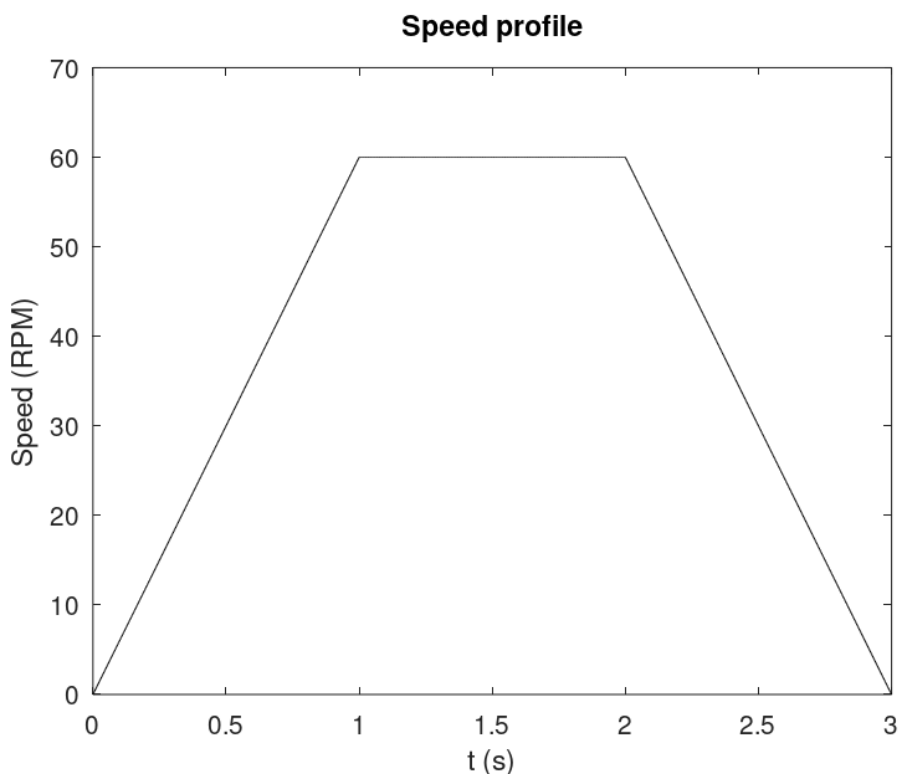

Figure 4.1: Speed profile example.

4.1 Fieldbus Modes

4.1.2 Positioning

This drive operation modes requires a specific target position, velocity, acceleration and deceleration, to compute the motion profile used to reach the target position. The position profile executed is of "S" type and the speed profile is trapezoidal.

In Figure 4.2 is shown an example of positioning profile with the following parameters:

- Initial position = 0 °
- Target position = 720 ° (target given at t = 0 s)
- Initial speed = 0 RPM
- Target speed = 60 RPM
- Target acceleration = 60 RPM / s
- Target deceleration = 60 RPM / s

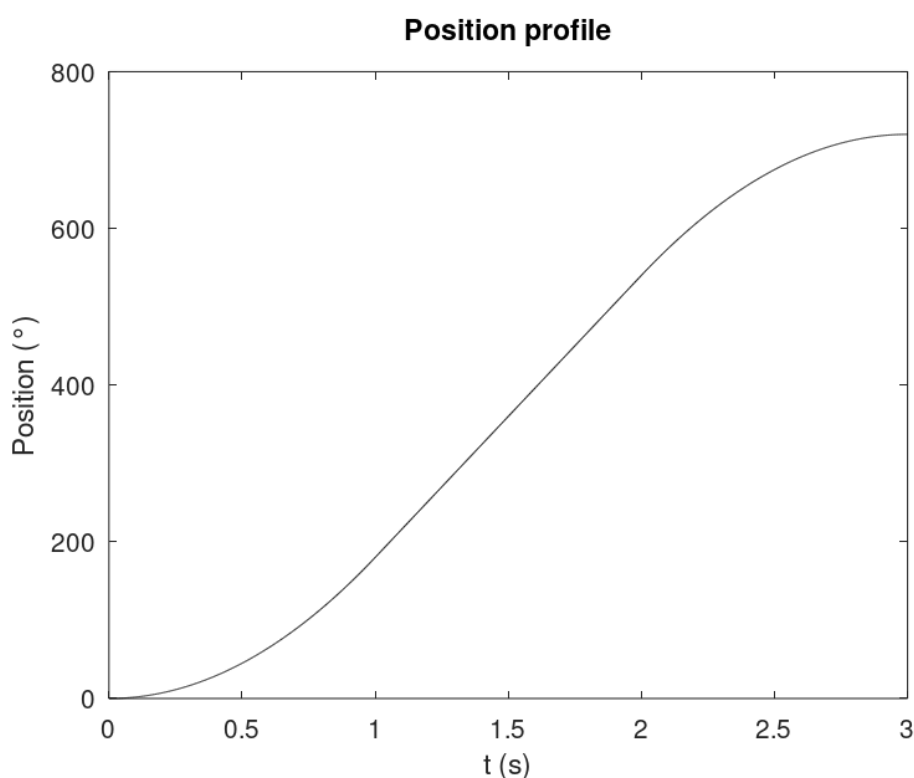

Figure 4.2: Positioning profile example.

In Figure 4.3 are represented both the position (continuous line) and speed (dashed line) profiles per unit (position / 360 ° and speed / 60 RPM).

4.1 Fieldbus Modes

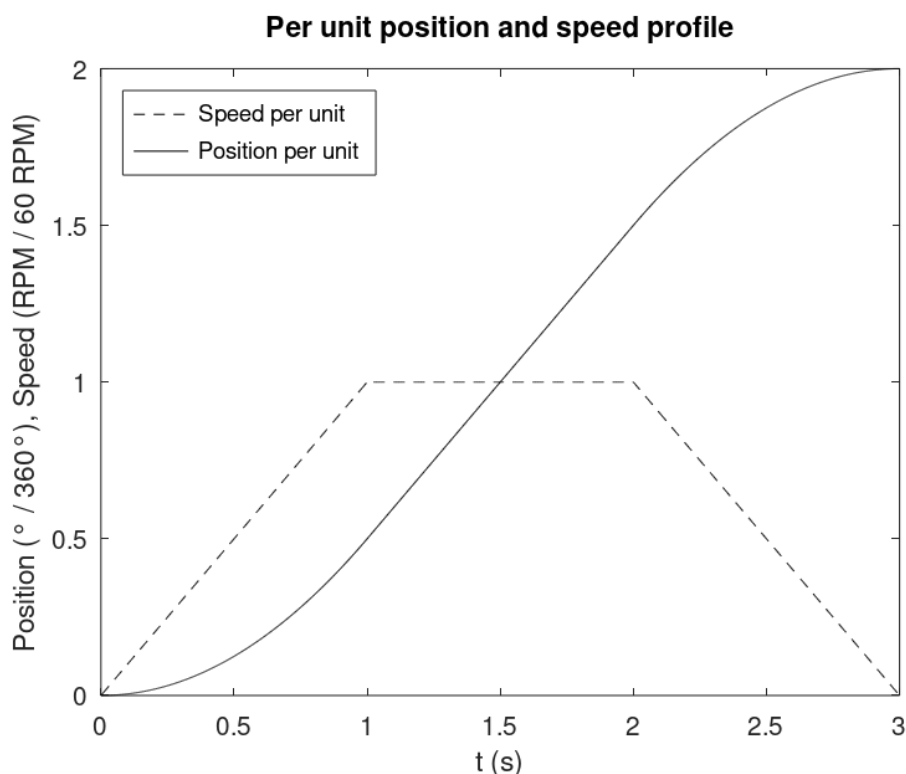

Figure 4.3: Positioning and speed profile example.

4.1.2.1 Relative Positioning

In relative positioning profile the target is computed as offset with respect to the current position. For example, if the actual absolute rotor position is 360° and the requested relative positioning target is 360° , the motor will rotate to reach the absolute position of 720° .

4.1.2.2 Absolute Positioning

In absolute positioning profile the target is absolute. For example, if the absolute rotor position is 360° and an absolute positioning target of 360° is given, the motor will not move.

4.1.3 Torque

This drive operation mode requires a specific target (current) torque, positive torque slope and negative torque slope. Target torque is expressed in mA and torque slopes in mA / s.

In Figure 4.4 is shown an example of torque profile with the following parameters:

- Positive torque slope = 1000 mA / s
- Negative torque slope = 1000 mA / s
- Initial torque = 0 mA
- Target torque = 1000 mA (target given at t = 0 s)
- Target torque = 0 mA (target given at t = 2 s)

4.1 Fieldbus Modes

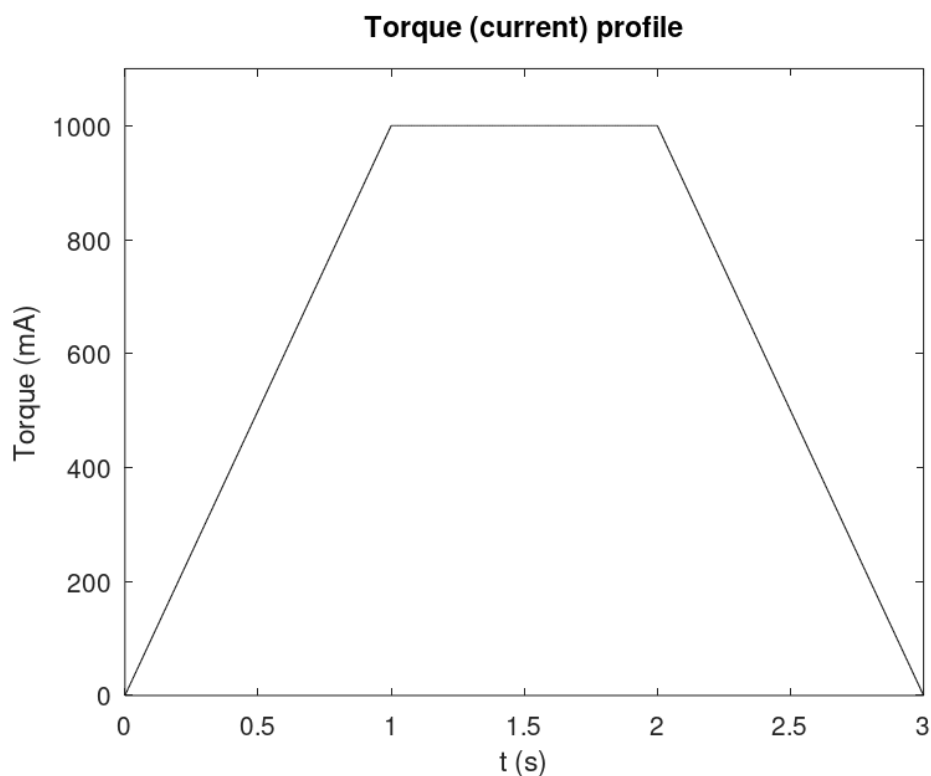

Figure 4.4: Torque (current) profile example.

4.1.4 Jog

The JOG mode allows to control the drive in speed mode using two bits of the controlword

Table 4.1: JOG truth table.

Bit 6	Bit 5	Effect
0	0	Stop (zero speed)
1	0	Clockwise rotation
0	1	Counter-clockwise rotation
1	1	Invalid command (previous state persists)

4.1 Fieldbus Modes

4.1.5 Homing

In this Section are described the possible homing procedures. It is mandatory to execute homing before using positioning operations. Homing parameters can be configured using UVIX interface (refer to Section 6.6.2.1). If proximity is used it must be connected to the PROXY INPUT (refer to Section 3.3.2).

4.1.5.1 Positioning homing

Homing at the current position (refer to Figure 4.5). This mode does not require an external proximity

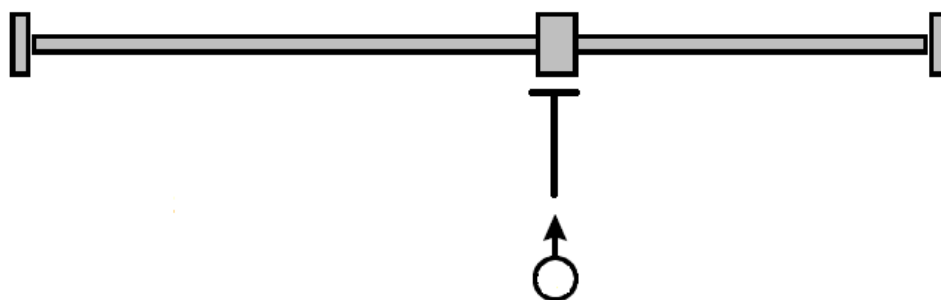

Figure 4.5: Positioning homing.

and the homing procedure consists of setting the current position (without moving the motor) as zero position.

4.1.5.2 Proximity homing: negative direction

Proximity search in negative direction (refer to Figure 4.6).

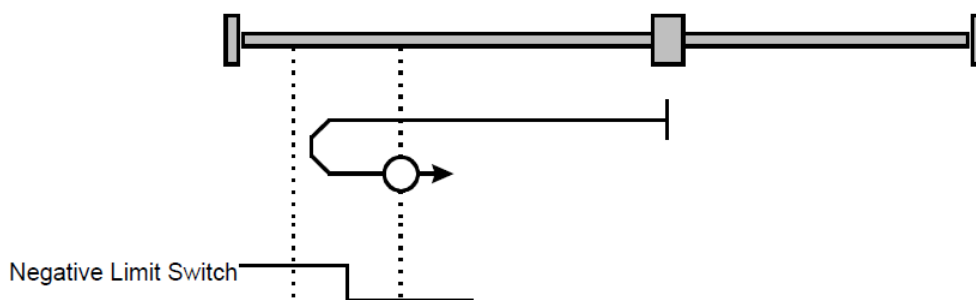

Figure 4.6: Proximity homing: negative direction.

In this mode, the motor searches for the zero proximity in the negative direction of the movement, with the velocity set to "homing speed search". As soon as the proximity is detected, the motor stops and exits the proximity, in the opposite direction, with the velocity set to "homing speed out". If the proximity is already detected on the start of the homing procedure, the motion will start with the "homing speed out" phase. If the proximity is surpassed because of the inadequate speed / deceleration combination, the homing procedure is interrupted and a homing error is returned.

4.1.5.3 Proximity homing: positive direction

Proximity search in positive direction (refer to Figure 4.7).

4.1 Fieldbus Modes

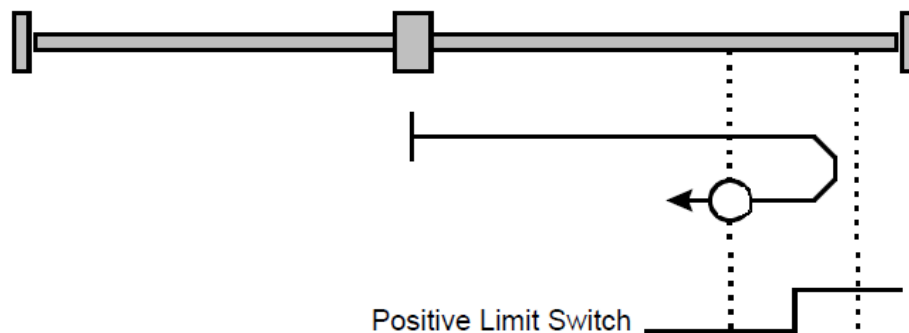

Figure 4.7: Proximity homing: positive direction.

In this mode, the motor searches for the zero proximity in the positive direction of the movement, with the velocity set to "homing speed search". As soon as the proximity is detected, the motor stops and exits the proximity, in the opposite direction, with the velocity set to "homing speed out". If the proximity is already detected on the start of the homing procedure, the motion will start with the "homing speed out" phase. If the proximity is surpassed because of the inadequate speed / deceleration combination, the homing procedure is interrupted and a homing error is returned.

4.1.5.4 Proximity homing: negative direction + zero encoder

Proximity search in negative direction and then search for the index pulse (zero of the encoder) in the positive direction (refer to Figure 4.8).

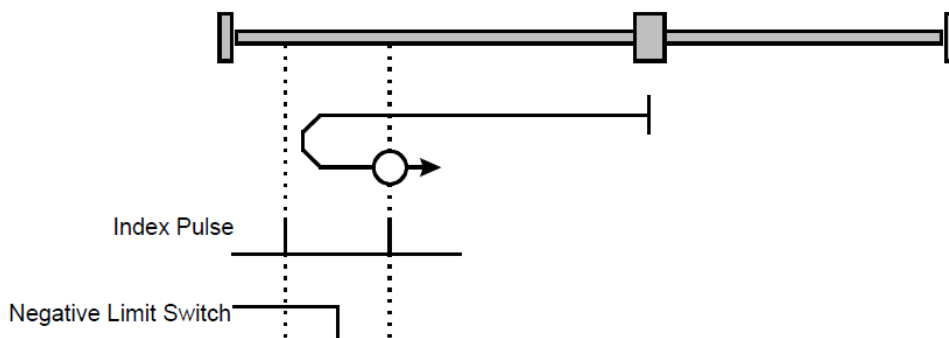

Figure 4.8: Proximity homing: negative direction + zero encoder.

In this mode, the motor searches for the zero proximity in the negative direction of the movement, with the velocity set to "homing speed search". As soon as the proximity is detected, the motor stops and exits the proximity, in the opposite direction, with the velocity set to "homing speed out", until it finds the zero encoder. If the proximity is already detected on the start of the homing procedure, the motion will start with the "homing speed out" phase. If the proximity is surpassed because of the inadequate speed / deceleration combination, the homing procedure is interrupted and a homing error is returned.

4.1 Fieldbus Modes

4.1.5.5 Proximity homing: positive direction + zero encoder

Proximity search in positive direction and then search for the index pulse (zero of the encoder) in the negative direction (refer to Figure 4.9).

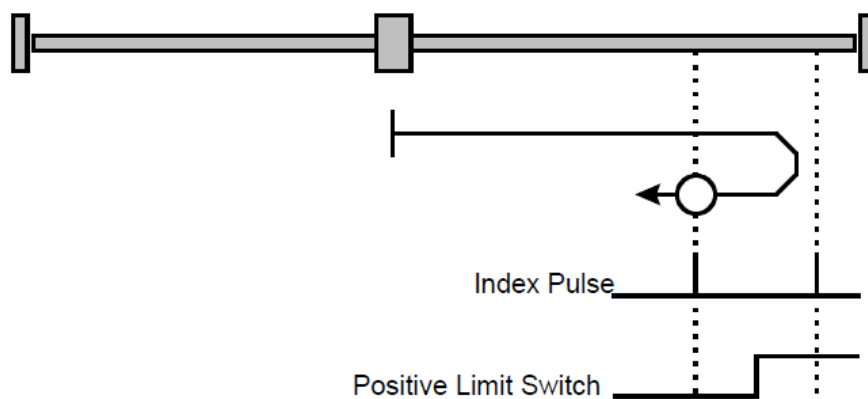

Figure 4.9: Proximity homing: positive direction + zero encoder.

In this mode, the motor searches for the zero proximity in the positive direction of the movement, with the velocity set to "homing speed search". As soon as the proximity is detected, the motor stops and exits the proximity, in the opposite direction, with the velocity set to "homing speed out", until it finds the zero encoder. If the proximity is already detected on the start of the homing procedure, the motion will start with the "homing speed out" phase. If the proximity is surpassed because of the inadequate speed / deceleration combination, the homing procedure is interrupted and a homing error is returned.

4.1.5.6 Torque homing: negative direction

Homing torque in negative direction (refer to Figure 4.10). In this mode the motor rotates in the neg-

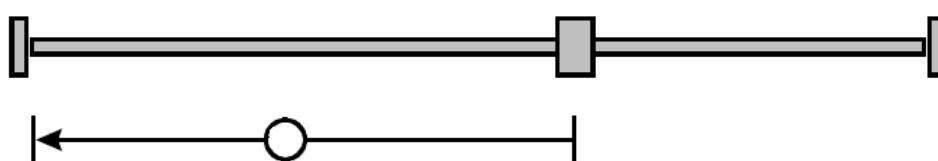

Figure 4.10: Torque homing: negative direction.

ative direction of the movement, with the velocity set to "homing speed search", until it stops against the end of the line and the I^2T reaches the homing set value.

4.1.5.7 Torque homing: positive direction

Homing torque in positive direction (refer to Figure 4.11). In this mode the motor rotates in the positive direction of the movement, with the velocity set to "homing speed search", until it stops against the end of the line and the I^2T reaches the homing set value.

4.1 Fieldbus Modes

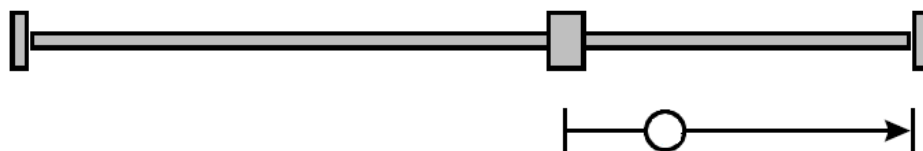

Figure 4.11: Torque homing: positive direction.

4.1.5.8 Torque homing: negative direction + zero encoder

Homing torque in negative direction and then search for the index pulse (zero of the encoder) in the positive direction (refer to Figure 4.12).

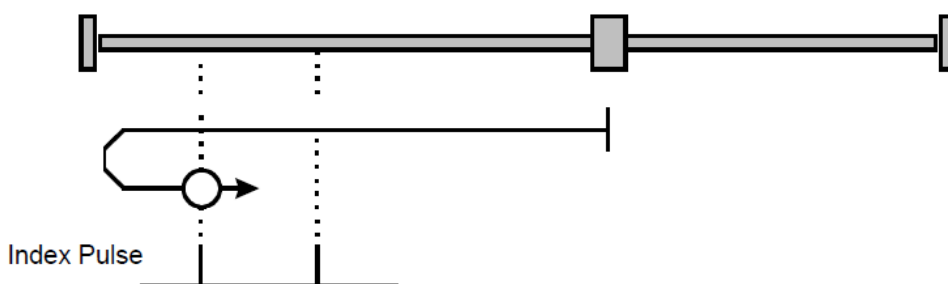

Figure 4.12: Torque homing: negative direction + zero encoder.

In this mode the motor rotates in the negative direction of the movement, with the velocity set to "homing speed search", until it stops against the end of the line and the I^2T reaches the homing set value. At this point the motor rotates in the opposite direction, with the velocity set to "homing speed out", until it finds the zero encoder.

4.1.5.9 Torque homing: positive direction + zero encoder

Homing torque in positive direction and then search for the index pulse (zero of the encoder) in the negative direction (refer to Figure 4.13).

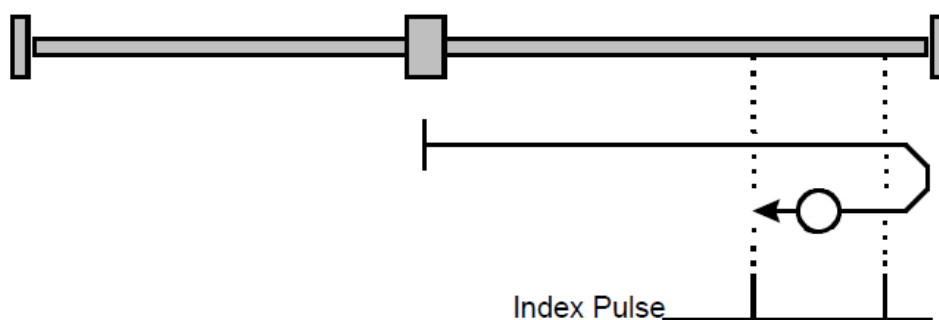

Figure 4.13: Torque homing: positive direction + zero encoder.

In this mode the motor rotates in the positive direction of the movement, with the velocity set to "homing speed search", until it stops against the end of the line and the I^2T reaches the homing set value. At this point the motor rotates in the opposite direction, with the velocity set to "homing speed out", until it finds the zero encoder.

4.1 Fieldbus Modes

4.1.5.10 Homing offset

The Homing offset indicates the configured difference between the **zero position** for the application and the machine **home position** (found during homing). During homing the motor moves to search the home position: it is possible to change the zero position, that by default is set at the same value of the home position, by adding an offset to the home position. This value could be positive or negative and all subsequent absolute movements shall be taken relative to this new zero position.

4.2 Digital Inputs mode

4.1.6 Other features

In this chapter are described other features that can be used in combination with the various modes of operation.

4.1.6.1 Profile software limits

Profile software limits can be set to restrict the motion parameters (positions, speed, acceleration and deceleration) to a desired value.

Such limits can be configured using the UVIX interface (refer to Section 6.5.1) and are valid for all the configurations different from "only motor" and for all the modes of operation.

Software limits take effect only after homing execution and if the corresponding "software limits enable" in the protocol is set (refer to Chapter 5 parameter 2010h). In case a position software limit error is triggered (for example the servo has been set momentary OFF and the motor has been moved beyond the software position limit or the EXT PROXY INPUT signal has been caught), the drive, if it was moving, stops itself using the QUICK_STOP that is the deceleration parameter set in UVIX (refer to Section 6.5.2) and it goes into error state and the correspondent error is raised on the fieldbus. In such situation, to bring back the motor into the allowed position range, the error must be reset first. Then, it is allowed to move the motor using any of the mode of operations (even if it is still out of the allowed range, because the software limit check will be momentary disabled). The error check on positioning will be restored automatically after the first movement completion (target position for positioning control or zero speed for speed control), provided that the "software limit enable" is still set.

Regarding target position, target speed, acceleration and deceleration values, if their target values exceed the limit value, the set is inhibited, that is, the parameter is not applied (the previous valid parameter remains valid) and the "command refused" warning is raised.

Profile position hardware limit: The position limit feature of Section 4.1.6.1 can be achieved also using a proximity sensor connected to the EXT PROXY INPUT (refer to Section 3.3.2). As soon as the EXT PROXY INPUT goes to HIGH state, the drive behaves as described in Section 4.1.6.1. Note that the hardware limit takes effect only if the "software limits enable" in the protocol is set.

4.1.6.2 Torque limit

Torque limitation is a feature that allows to limit the torque (current) supplied by the motor. This feature can be enabled and disabled using the provided "torque limit enable" in the protocol (refer to Chapter 5, parameter 2015h.) and it takes effect for all the modes of operation. The current limit value is configured using the fieldbus interface and it can be changed in real-time using the Target torque parameter (refer to Chapter 5).

4.2 Digital Inputs mode

The drive can be configured to be moved only using digital inputs signals. This functionality excludes the fieldbus and the motor can be moved in speed mode using only inputs IN1 and IN2 to decide the direction of the movement. PROXY EXT and PROXY INPUT can be used as limits of the range of movement

4.2 Digital Inputs mode

(refer to Section 3.3.2). The UVIX application must be used to set and enable the Digital Inputs mode and to set and store in nonvolatile memory the specific parameters of this mode. After these operations, the drive must be rebooted (turn OFF and ON the VL logic power supply) to apply the configuration. In Table 4.2 is shown the truth table of the Digital Inputs mode. Note that the option "rotation direction", settable via UVIX, is ignored when the drive is in Digital Inputs mode.

Table 4.2: Digital Inputs truth table.

IN1	IN2	Effect
LOW	LOW	Stop (zero speed)
HIGH	LOW	Clockwise rotation
LOW	HIGH	Counter-clockwise rotation
HIGH	HIGH	Invalid command (previous state persists)

When the user changes the IN1 or IN2 logical status to value one, the drive begins to move until:

- it reaches one of the PROXIES and in this case it automatically stops itself or
- the user set IN1 and IN2 to the zero logical value.
- the drive has some problems and it stops in error: in this case the only way to know which type of error, it is to check the number of flashes of the error LED; if the drive goes in error, automatically servo will be OFF.

CANopen Protocol

This Chapter describes how to configure and control the drive with a CANopen PLC.

5.1 Conventions

In this Section is given a description about the conventions used in this manual.

The data types used are shown in Table 5.1:

Table 5.1: Data types.

Name	Size
S32	32 bit signed
U32	32 bit unsigned
S16	16 bit signed
U16	16 bit unsigned
S8	8 bit signed
U8	8 bit unsigned
STR	string

In Table 5.2 are shown the units of measurement used by the drive.

Table 5.2: Units of measurement.

Quantity	Unit
Position	Degrees · 100 (*)
	mm · 100 (**)
Speed	RPM · 100 (*)
	mm / s · 100 (**)
Acceleration	RPM / s (*)
	mm / s ² (**)
	mA / s (***)
Deceleration	RPM / s (*)
	mm / s ² (**)
	mA / s (***)
Torque (current)	mA

(*) Used when the drive is configured as "only motor".

(**) Used in all other configurations different from "only motor".

(***) Used in torque (current) control.

A positive position or a positive speed target cause the motor shaft to rotate in a clockwise direction, when the motor shaft is viewed from the front. Example: a position target of 36000, when the drive is configured as "only motor", corresponds to one turn of the shaft in a clockwise direction.

5.2 Configuration via EDS file

5.2 Configuration via EDS file

To configure the DRVI in a CANopen network, the EDS file must be imported into the programming software used for the controller. The configuration file describes the working characteristics of the CANopen device.

5.3 Object dictionary

Inside the EDS file is present the dictionary with all the objects necessary for the communications and for the management of the drive. Its structure follows the CANopen CiA 301 and CiA 402 standards. In the following Sections is given a description of the dictionary.

5.3.1 Communication Profile - CiA 301 objects

In Table 5.3 are listed the CiA 301 objects.

Table 5.3: CiA 301 objects.

ID	Sub	Description	Type	Access	PDO Mapping	Default Value
1000h	0	Device Type	U32	RO		0xFF7A0192
1001h	0	Error Register	U8	RO	Yes	
1002h	0	Manufacturer status Register	U32	RO	Yes	
1003h		Pre defined error list				
	0	Number of errors	U32	RO		
	1	Standard error field	U32	RO		
	2	Standard error field	U32	RO		
	3	Standard error field	U32	RO		
	4	Standard error field	U32	RO		
	5	Standard error field	U32	RO		
	6	Standard error field	U32	RO		
	7	Standard error field	U32	RO		
	8	Standard error field	U32	RO		
1005h	0	COBID Sync	U32	RW		0x00000080
1006h	0	Communication cycle period	U32	RW		0
1007h	0	Synchronous Window Length	U32	RW		0
1008h	0	Manufacturer Device Name	STR	CONST		DRVI
1009h	0	Manufacturer Hardware Version	STR	CONST		1
100Ah	0	Manufacturer Software Version	STR	CONST		0
100Ch	0	Guard Time	U16	RW		0
100Dh	0	Life Time Factor	U16	RW		0
1010h		Store parameters field				
	0	Highest sub-index supported	U32	RO		

Continued on next page.

5.3 Object dictionary

Table 5.3 – Continued from previous page.

ID	Sub	Description	Type	Access	PDO Mapping	Default Value
	1	Save all Parameters	U32	RW		0
1014h	0	COB-ID EMCY	U32	RO		0x00000080
1015h	0	Inhibit Time Emergency	U16	RW		0
1017h	0	Producer Heartbeat Time	U16	RW		0
1018h		Identity object				
	0	number of entries	U8	RO		4
	1	Vendor Id	U32	RO		0x00000097
	2	Product Code	U32	RO		0x0000005A
	3	Revision number	U32	RO		0x0000001
	4	Serial number	U32	RO		0
1400h		Receive PDO Communication Parameter 1				
	0	Highest sub-index supported	U8	RO		0x02
	1	COB-ID	U32	RW		0x00000200
	2	Transmission type	U8	RW		0xFF
1401h		Receive PDO Communication Parameter 2				
	0	Highest sub-index supported	U8	RO		0x02
	1	COB-ID	U32	RW		0x80000300
	2	Transmission type	U8	RW		0xFF
1402h		Receive PDO Communication Parameter 3				
	0	Highest sub-index supported	U8	RO		0x02
	1	COB-ID	U32	RW		0x80000400
	2	Transmission type	U8	RW		0xFF
1403h		Receive PDO Communication Parameter 4				
	0	Highest sub-index supported	U8	RO		0x02
	1	COB-ID	U32	RW		0x80000500
	2	Transmission type	U8	RW		0xFF
1404h		Receive PDO Communication Parameter 5				
	0	Highest sub-index supported	U8	RO		0x02
	1	COB-ID	U32	RW		0x80000680
	2	Transmission type	U8	RW		0xFF
1405h		Receive PDO Communication Parameter 6				
	0	Highest sub-index supported	U8	RO		0x02
	1	COB-ID	U32	RW		0x80000000

Continued on next page.

5.3 Object dictionary

Table 5.3 – Continued from previous page.

ID	Sub	Description	Type	Access	PDO Mapping	Default Value
	2	Transmission type	U8	RW		0xFF
1406h		Receive PDO Communication Parameter 7				
	0	Highest sub-index supported	U8	RO		0x02
	1	COB-ID	U32	RW		0x80000000
	2	Transmission type	U8	RW		0xFF
1407h		Receive PDO Communication Parameter 8				
	0	Highest sub-index supported	U8	RO		0x02
	1	COB-ID	U32	RW		0x80000000
	2	Transmission type	U8	RW		0xFF
1600h		Receive PDO Mapping Parameter1				
	0	Number of mapped objects	U8	RW		0x01
	1	Mapping Entry 1	U32	RW		0x60400010
	2	Mapping Entry 2	U32	RW		0
	3	Mapping Entry 3	U32	RW		0
	4	Mapping Entry 4	U32	RW		0
	5	Mapping Entry 5	U32	RW		0
	6	Mapping Entry 6	U32	RW		0
	7	Mapping Entry 7	U32	RW		0
	8	Mapping Entry 8	U32	RW		0
1601h	0	Receive PDO Mapping Parameter2				
1602h	0	Receive PDO Mapping Parameter3				
1603h	0	Receive PDO Mapping Parameter4				
1604h	0	Receive PDO Mapping Parameter5				
1605h	0	Receive PDO Mapping Parameter6				
1606h	0	Receive PDO Mapping Parameter7				
1607h	0	Receive PDO Mapping Parameter8				
1800h		Transmit PDO Communication Parameter 1				
	0	Highest sub-index supported	U8	RO		0x05
	1	COB-ID	U32	RW		0x00000180

Continued on next page.

5.3 Object dictionary

Table 5.3 – Continued from previous page.

ID	Sub	Description	Type	Access	PDO Mapping	Default Value
	2	Transmission Type	U8	RW		0xFF
	3	Inhibit Time	U16	RW		0
	4	Compatibility Entry	U8	RW		0
	5	Event Timer	U16	RW		0x0064
1801h		Transmit PDO Communication Parameter 2				
	0	Highest sub-index supported	U8	RO		0x05
	1	COB-ID	U32	RW		0x80000280
	2	Transmission Type	U8	RW		0xFF
	3	Inhibit Time	U16	RW		0
	4	Compatibility Entry	U8	RW		0
	5	Event Timer	U16	RW		0
1802h		Transmit PDO Communication Parameter 3				
	0	Highest sub-index supported	U8	RO		0x05
	1	COB-ID	U32	RW		0x80000380
	2	Transmission Type	U8	RW		0xFF
	3	Inhibit Time	U16	RW		0
	4	Compatibility Entry	U8	RW		0
	5	Event Timer	U16	RW		0
1803h		Transmit PDO Communication Parameter 4				
	0	Highest sub-index supported	U8	RO		0x05
	1	COB-ID	U32	RW		0x80000480
	2	Transmission Type	U8	RW		0xFF
	3	Inhibit Time	U16	RW		0
	4	Compatibility Entry	U8	RW		0
	5	Event Timer	U16	RW		0
1804h		Transmit PDO Communication Parameter 5				
	0	Highest sub-index supported	U8	RO		0x05
	1	COB-ID	U32	RW		0x80000000
	2	Transmission Type	U8	RW		0xFF
	3	Inhibit Time	U16	RW		0
	4	Compatibility Entry	U8	RW		0
	5	Event Timer	U16	RW		0
1805h		Transmit PDO Communication Parameter 6				
	0	Highest sub-index supported	U8	RO		0x05
	1	COB-ID	U32	RW		0x80000000

Continued on next page.

5.3 Object dictionary

Table 5.3 – Continued from previous page.

ID	Sub	Description	Type	Access	PDO Mapping	Default Value
	2	Transmission Type	U8	RW		0xFF
	3	Inhibit Time	U16	RW		0
	4	Compatibility Entry	U8	RW		0
	5	Event Timer	U16	RW		0
1806h		Transmit PDO Communication Parameter 7				
	0	Highest sub-index supported	U8	RO		0x05
	1	COB-ID	U32	RW		0x80000000
	2	Transmission Type	U8	RW		0xFF
	3	Inhibit Time	U16	RW		0
	4	Compatibility Entry	U8	RW		0
	5	Event Timer	U16	RW		0
1807h		Transmit PDO Communication Parameter 8				
	0	Highest sub-index supported	U8	RO		0x05
	1	COB-ID	U32	RW		0x80000000
	2	Transmission Type	U8	RW		0xFF
	3	Inhibit Time	U16	RW		0
	4	Compatibility Entry	U8	RW		0
	5	Event Timer	U16	RW		0
1A00h		Transmit PDO Mapping Parameter 1				
	0	Number of mapped objects	U8	RW		0x01
	1	Mapping Entry 1	U32	RW		0x60410010
	2	Mapping Entry 2	U32	RW		0
	3	Mapping Entry 3	U32	RW		0
	4	Mapping Entry 4	U32	RW		0
	5	Mapping Entry 5	U32	RW		0
	6	Mapping Entry 6	U32	RW		0
	7	Mapping Entry 7	U32	RW		0
	8	Mapping Entry 8	U32	RW		0
1A01h	0	Transmit PDO Mapping Parameter 2				
1A02h	0	Transmit PDO Mapping Parameter 3				
1A03h	0	Transmit PDO Mapping Parameter 4				
1A04h	0	Transmit PDO Mapping Parameter 5				

Continued on next page.

5.3 Object dictionary

Table 5.3 – Continued from previous page.

ID	Sub	Description	Type	Access	PDO Mapping	Default Value
1A05h	0	Transmit PDO Mapping Parameter 6				
1A06h	0	Transmit PDO Mapping Parameter 7				
1A07h	0	Transmit PDO Mapping Parameter 8				
1F80h	0	NMT Startup	U32	RW		0x00000004

5.3.2 CiA 301 objects descriptions

In the following Sections are described the CiA 301 objects.

5.3.2.1 1000h Device type

This object contains information on the type of device and its functions. It consists in a two 16-bit fields, one describing the profile used, and a second containing additional specific information.

5.3.2.2 1001h Error register

This object contains the device's internal error mapping, it is a mandatory object for all devices and it is part of the emergency objects. The bit-field values are defined in Table 5.4.

Table 5.4: Error Bit-field.

Bit	Optional	Description
0	Mandatory	Generic error
1	Optional	Current
2	Optional	Voltage
3	Optional	Temperature
4	Optional	Communication error
5	Optional	Profile specific
6	Optional	Reserved
7	Optional	Reserved

5.3.2.3 1002h Manufacturer status register

This object contains the device status. It is manufacturer-specific.

5.3.2.4 1003h Pre-defined error field

This object contains errors that have been identified on the device and have been signaled by the emergency message. This creates an error history. Sub-index 0 contains the number of errors that are currently saved, from sub-index 1 to sub-index 8. When there are no errors, it takes the value zero. Each new error is saved at index 1 and the old ones are moved up by one index. Entering zero into sub-index 0

5.3 Object dictionary

deletes the error history, resetting all saved errors to zero. Each error consists in a 16-bit field containing the error code, defined by CANopen, and another 16-bit field containing additional manufacturer information. Error values are listed in Table 5.5.

Table 5.5: Error Values.

Manufacturer info	Error type
0x2310	Overcurrent error
0x3120	Power voltage absent/too low error
0x4210	Temperature too high error
0x5530	Flash data lost
0x5540	Hardware enable not present error
0x6100	Internal software error
0x6320	Motor configuration error
0x7305	Position, step loss (if external encoder present) error
0x7320	Positioning out of software limits error
0x8613	Homing procedure timeout error
0xFF13	Operation without reset

5.3.2.5 1005h COB-ID sync

This object contains the COB-ID configuration of the synchronization message (SYNC), indicating whether or not the device generates the sync message (refer to Table 5.6).

Table 5.6: COB-ID Sync.

Bit	Value	Description
31	x	Reserved
30	0	Does not generate SYNC message
	1	Generates SYNC message
29	0	11-bit CAN-ID
	1	29-bit CAN-ID
28-0 or 11-0	x	CAN-ID or the CAN extended frame

5.3.2.6 1006h Communication cycle period

This object contains the cyclic communication period for SYNC messages in milliseconds. When its value is zero the device does not send synchronous messages.

5.3.2.7 1007h Synchronous Window Length

This object contains the synchronous window length for PDO messages i.e. the time from the synchronization message within which the synchronous PDOs must arrive in order to be valid. If the value is set to zero, the synchronization window is disabled.

5.3.2.8 1008h Manufacturer hardware name

This object contains the device name given by the manufacturer.

5.3 Object dictionary

5.3.2.9 1009h Manufacturer hardware version

This object contains the hardware version of the device.

5.3.2.10 100Ah Manufacturer software version

This object contains the firmware version of the device.

5.3.2.11 100Ch Guard time

This object, together with the next 100Dh, represent the configuration of the "life guarding" protocol. The guard time contains the period in which the "guarding" message is sent. It is expressed in milliseconds and if it is set to zero, the "life guarding" protocol is disabled.

5.3.2.12 100Dh Life time factor

This object contains the number of "guarding" messages that can be lost. This value multiplied by the "Guard time" is the maximum amount of time within which the guarding messages must arrive in order to avoid an error and reset the communication.

5.3.2.13 1010h Store parameter field

This object stores the parameters in non-volatile memory. Sub-index 1 refers to saving all objects supported by the device. To avoid unintentionally saving data, saving is only performed if the "save" signature 0x65766173 is written in the object.

5.3.2.14 1011h Restore parameter field

This object restores the parameters from non-volatile memory. Sub-index 1 refers to saving all objects supported by the device. To avoid unintentionally saving data, saving is only performed if the "save" signature 0x64616F6C is written in the object.

5.3.2.15 1014h COB-ID EMCY

This object contains the EMCY service configuration (refer to Table 5.7).

Table 5.7: COB-ID Sync.

Bit	Value	Description
31	0	EMCY present / valid
	1	EMCY absent / invalid
30	0	Reserved
29	0	11-bit CAN-ID
	1	29-bit CAN-ID
28-0 or 11-0	x	CAN-ID or the CAN extended frame

5.3 Object dictionary

5.3.2.16 1015h Inhibit time emergency

This object contains the inhibit time of the EMCY message, which must be a multiple of 100 μ s. If set to zero it disables the inhibit time.

5.3.2.17 1017h Producer heartbeat time

This object contains the heartbeat protocol configuration, indicating the period in which the heartbeat message is produced. The period must be a multiple of 1 ms and if it set to zero, the heartbeat management will be disabled.

5.3.2.18 1018h Identity object

This object contains information about the device. Refer to Table 5.8 for detailed description.

Table 5.8: Identity object.

Sub index	Value	Description
0	4	EMCY present / valid
1	97h	Vendor ID
2	5Ah	Product code
3	1	Revision number
4	0	Serial number

5.3.2.19 1400h – 1407h Rx PDO communication parameter

These objects contain the configuration of the PDO communication that the device can receive. The PDO transmission parameters are described in the document CiA 301, Section 7.4.8.1. Sub-index 1 contains the COB-ID of the PDO (refer to Table 5.9):

Table 5.9: COB-ID RPDO.

Bit	Value	Description
31	0	PDO present / valid
	1	PDO absent / invalid
30	x	Reserved
29	0	11-bit CAN-ID
	1	29-bit CAN-ID
28-0 or 11-0	x	CAN-ID or the CAN extended frame

Sub-index 2 contains the transmission type (refer to Table 5.10):

Table 5.10: COB-ID RPDO.

Value	Description
0	Synchronous transmission (with SYNC messages)
1-240	Synchronous transmission every N SYNC messages
252-253	Transmission only on transmission request (RTR)
254	Asynchronous transmission specific to manufacturer
255	Asynchronous transmission specific to device profile

5.3 Object dictionary

RPDOs with transmission type set to 255 require the immediate updating of all mapped objects, as foreseen by the CiA drive specifications.

5.3.2.20 1600h – 1607h Receive PDO Mapping Parameter

These objects contain the PDO mapping that the device is able to receive. Sub-index 0 contains the number of objects mapped in the PDO; if the value is set to zero, it means that no object is mapped. Each sub-index from 1 to the previously specified number contains information on the object mapped in the PDO.

In the following list is described the sequence for changing the mapping of a PDO:

- *Disable the Rx PDO by setting bit 31, in sub-index 1 of the RPDO communication parameter, to a value of 1.*
- *Disable the existing mapping by setting sub-index 0 to zero.*
- *Change the mapping by editing the value of the corresponding sub-index.*
- *Enable mapping by setting sub-index 0 to the number of mapped objects.*
- *Enable the Rx PDO by setting bit 31, in sub-index 1 of the RPDO communication parameter, to the value 0.*

5.3.2.21 1800h – 1807h Tx PDO communication parameter

These objects contain the configuration of the PDO communication that the device can transmit. The PDO transmission parameters are described in the document CiA301, section 7.4.8.1. Sub-index 1 contains the COB-ID of the PDO.

Table 5.11: COB-ID TPDO.

Bit	Value	Description
31	0	PDO present / valid
	1	PDO absent / invalid
30	x	Reserved
29	0	11-bit CAN-ID
	1	29-bit CAN-ID
28-0 or 11-0	x	CAN-ID or the CAN extended frame

Sub-index 2 contains the transmission type:

Table 5.12: COB-ID TPDO.

Value	Description
0	Synchronous transmission (with SYNC messages)
1-240	Synchronous transmission every N SYNC messages
252-253	Transmission only on transmission request (RTR)
254	Asynchronous transmission specific to manufacturer
255	Asynchronous transmission specific to device profile

Sub-index 3 contains the minimum time interval with which the TPDO can be transmitted when the transmission type set is 255 or 254. This value is a multiple of 100 μ s; if it is set to zero, the minimum interval is disabled. Sub-index 4 is reserved. Sub-index 5 contains the maximum time interval with

5.3 Object dictionary

which the TPDO is transmitted when the set transmission type is 255 or 254. This value is a multiple of 1 ms; if it is set to zero, the maximum interval is disabled.

5.3.2.22 1A00h – 1A07h Tx PDO mapping parameter

Analogous to for RxPDO mapping (refer to Section 5.3.2.20).

5.3.2.23 1F80h NMT Start-up

This object contains the drive startup behaviour configuration, the bit description of its value is reported in Table 5.13:

Table 5.13: NMT Start-up.

Bit	Value	Description
31-7	0	Reserved
6	x	Stop all nodes
5	x	Flying Master
4	x	Reset all nodes
3	x	Start node
2	x	NMT master start
1	x	Start all nodes
0	x	NMT master

This object determines the startup behavior of a device in the network. This object is bit-codes as follow for bit value = 1:

- bit 0: Node is NMT master.
- bit 1: NMT service Start Remote Node with value 0 is supported.
- bit 2: Shall not switch into the state NMT/OPERATIONAL by itself.
- bit 3: The NMT master shall not start the NMT slaves and the application may start the NMT slaves.
- bit 4: NMT service Reset Node with value 0 is supported.
- bit 5: Node has Flying Master capability and shall participate on the NMT Flying Master negotiation.
- bit 6: In case of an error control event defined as mandatory the NMT service Stop Remote Node with value 0 shall be executed. Bit 4 shall be ignored.
- other: reserved content...

5.3 Object dictionary

5.3.3 Device Profile - CiA 402 objects

In Table 5.14 are listed the CiA 402 objects.

Table 5.14: CiA 402 objects.

ID	Sub	Description	Type	Access	PDO Mapping	Default Value
603Fh	0	Error Code	U16	RO	TPDO	
6040h	0	Controlword	U16	RW	RPDO	0
6041h	0	Statusword	U16	RO	TPDO	0
6060h	0	Mode of operation	S8	RW	RPDO	0
6061h	0	Mode of operation display	S8	RO	TPDO	0
6062h	0	Position Demand Value	S32	RO		0
6064h	0	Position Actual Value	S32	RO	TPDO	0
6065h	0	Following error window	U32	RO		0
6066h	0	Following error timeout	U16	RO		0
606Bh	0	Velocity Demand Value	S32	RO		0
606Ch	0	Velocity Actual Value	S32	RO	TPDO	0
606Fh	0	Velocity Threshold	U16	RW		0
6070h	0	Velocity Threshold Time	U16	RW		0
6071h	0	Target torque	S16	RW	RPDO	0
6074h	0	Torque demand value	S16	RO		0
6077h	0	Torque actual value	S16	RO		0
607Ah	0	Target position	S32	RW	RPDO	0
607Ch	0	Home offset	S32	RW	RPDO	0
607Eh	0	Polarity	U8	RW	RPDO	0
6081h	0	Profile Velocity in pp-mode	U32	RW	RPDO	0
6083h	0	Profile Acceleration	U32	RW	RPDO	0
6084h	0	Profile Deceleration	U32	RW	RPDO	0
6087h	0	Torque slope	U32	RW		0
6091h		Gear Ratio				
	0	Highest sub-index supported	U8	RO		
	1	MotorRevs	U32	RW		0
	2	ShaftRevs	U32	RW		0
6098h	0	Homing Method	S8	RW	RPDO	37
6099h		Homing Speeds				
	0	Highest sub-index supported	U8	RO		
	1	Fast Homing Speed	U32	RW	RPDO	0
	2	Slow Homing Speed	U32	RW	RPDO	0
609Ah	0	Homing acceleration	U32	RW		0
60FFh	0	Target Velocity	S32	RW	RPDO	0

5.3.4 CiA 402 objects descriptions

In the following Sections are described the CiA 402 objects.

5.3 Object dictionary

5.3.4.1 603Fh Error code

This object contains the last error code that occurred on the drive, it is the same information present in object 1003h, sub-index 1.

5.3.4.2 6040h Controlword

This object checks the drive status and function. It is used to enable / disable power and start / stop a movement. This object together with the "status word" are used for the management of the state machine of the CiA402 profile (refer to the relative manual CiA402-2).

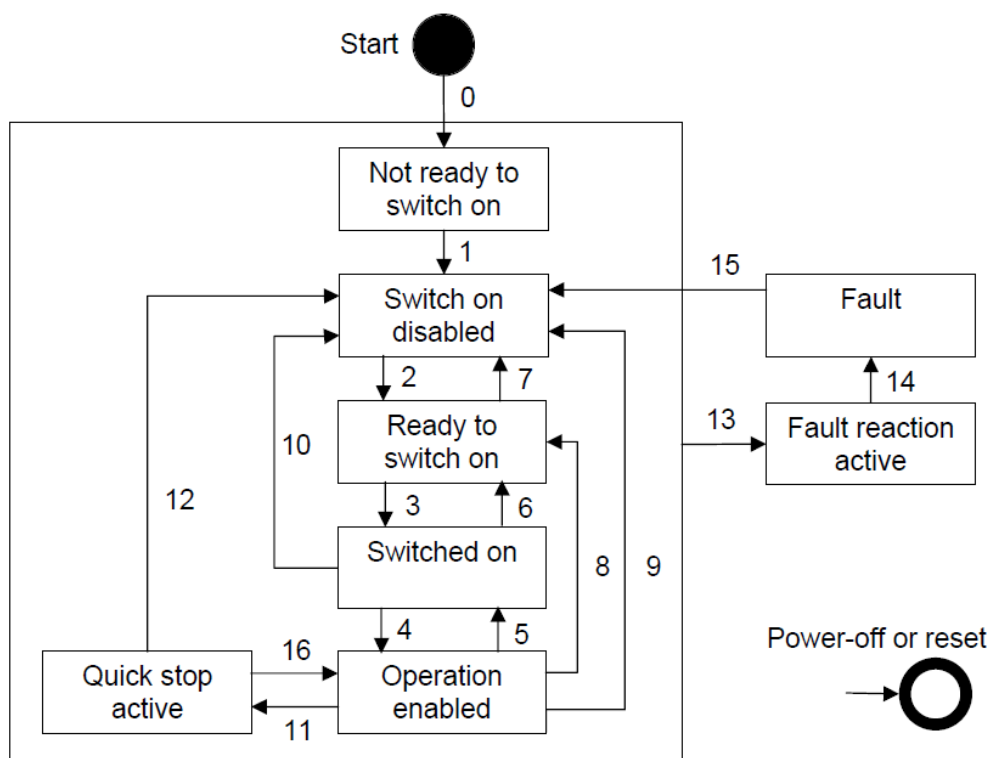

Figure 5.1: Power drive system finite state automaton.

The word is subdivided into bits with the following meanings:

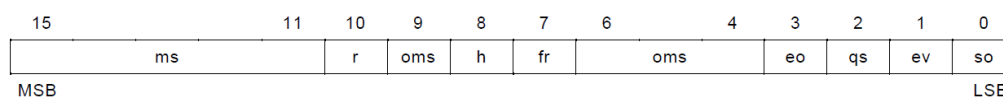

Figure 5.2: Controlword bits

- ms = manufacturer specifications
- r = reserved
- oms = dependent on operating mode
- h = halt
- fr = error reset
- eo = enable command
- qs = quick stop
- ev = enable power

5.3 Object dictionary

- so = startup

The possible commands to change the drive status are summarized in Table 5.15.

Table 5.15: Controlword bits.

Commands	fr (bit7)	eo (bit3)	qs (bit2)	ev (bit1)	so (bit0)	FSA
Shutdown	0	x	1	1	0	2, 6, 8
Switch on	0	0	1	1	1	3
Enable operation	0	x	1	1	1	4, 16
Disable voltage	0	x	x	0	x	7, 9, 10, 12
Quick stop	0	x	0	1	x	7, 10, 11
Disable operation	0	0	1	1	1	5
Fault reset	1	x	x	x	x	15

The bit 8 is the halt function and it interrupts the command execution, but as soon as it is reset, the command resumes (if possible) depending on the operating mode.

5.3.4.3 6041h Statusword

The status word (see Figure 5.3) is a read-only object that represents the current status of the drive. It is subdivided into bits with the following meanings:

- ms = manufacturer specifications (bit 14 = torque limit active)
- oms = dependent on operating mode
- ila = internal limits active (software limits enabled)
- tr = target reached
- rm = remote
- w = warning (drive status does not change)
- sod = operation disabled
- qs = quick stop
- ve = voltage enabled
- f = error (drive in error status)
- oe = command enabled
- so = active operation
- rtso = ready for operation

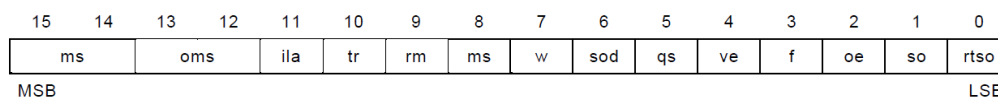

Figure 5.3: Statusword bits.

In Table 5.16 is shown the statusword bit configuration according to the possible drive status.

5.3 Object dictionary

Table 5.16: Statusword bits.

statusword (bit15 ... bit0)	Drive status
xxxx xxxx x0xx 0000	Not ready to operate
xxxx xxxx x1xx 0000	Operation disabled
xxxx xxxx x01x 0001	Ready for operation
xxxx xxxx x01x 0011	Operation active
xxxx xxxx x01x 0111	Command active
xxxx xxxx x00x 0111	Quick stop active
xxxx xxxx x0xx 1111	Error during command
xxxx xxxx x0xx 1000	Drive in error status

5.3.4.4 6060h Mode of operation

This object contains the drive operating mode request. The operating modes are specified in Table 5.17.

Table 5.17: Mode of operation bits.

Value	Operating mode
-1	Jog mode
0	No mode requested
1	Position profile
3	Velocity profile
4	Torque profile
6	Homing mode

5.3.4.5 6061h Mode of operation display

This object contains the operating mode value in which the drive is located. It can be one of the profiles listed in Table 5.17.

5.3.4.6 6064h Position actual value

This object contains the current position value measured by the drive, expressed in the unit of measurement set.

5.3.4.7 606Ch Velocity actual value

This object contains the actual velocity value measured by the drive, expressed in the unit of measurement set.

5.3.4.8 606Fh Velocity threshold

This object contains the zero velocity threshold value. When the current velocity is lower than the minimum time threshold set in the next object, the motor is considered stationary and bit 12 of the statusword is set.

5.3 Object dictionary

5.3.4.9 6070h Velocity threshold time

This object contains the minimum time in which the current velocity must remain below the threshold value, specified in the previous object, for the motor to be considered stationary, and then set bit 12 of the statusword.

5.3.4.10 6071h Target torque

This object shall indicate the configured input value for the torque controller in profile torque mode, position mode and velocity mode.

5.3.4.11 6074h Torque demand value

This object shall provide the output value of the trajectory generator.

5.3.4.12 6077h Torque actual value

This object shall provide the actual value of the torque. It shall correspond to the instantaneous torque in the motor.

5.3.4.13 607Ah Target position

This object contains the position that the motor must reach when the operation is in the position profile, using the velocity and acceleration parameters specified by the designated objects. The target position can be considered as an absolute or relative value according to the bit "abs / rel" of the controlword (specific bits for the profile). Upon reaching the position, bit 10 "target reached" of the statusword is set.

5.3.4.14 607Ch Home offset

This object contains the offset to apply to the physical zero position (imposed by the proximity position) to obtain the zero position of the motor. The drive executes the homing procedure requested (stop on proximity, stop on zero encoder, stop on torque threshold, etc ...) and when it is finished, it sets the actual position to the offset value.

5.3.4.15 607Eh Polarity

This object allows the motor rotation direction to be reversed, in order to change the movement direction, based on the physical mounting of the motor. Setting bit 7 reverses the rotation direction, as shown in Table 5.18.

NOTE: this parameter has an impact to ALL the mode of operation (homings, positioning, speed, torque)

Table 5.18: Polarity values.

Value	Direction
0x00	Forward
0x80	Reverse

5.3 Object dictionary

5.3.4.16 6081h Profile velocity in pp-mode

This object contains the value of the velocity reached after the acceleration phase, during the position profile movement, valid for both directions.

5.3.4.17 6083h Profile acceleration

This object contains the acceleration value used during the position profile movement, which determines the ramp with which the velocity set in the previous object will be reached.

5.3.4.18 6083h Profile deceleration

This object contains the deceleration value used during the position profile movement, which determines the ramp with which the zero velocity will be reached.

5.3.4.19 6087h Torque slope

This object shall indicate the configured rate of change of torque. The value shall be given in units of per thousand of rated torque per second.

5.3.4.20 6091h Gear ratio

This object shall indicate the configured number of motor shaft revolutions and the number of driving shaft revolutions. The gear ratio shall be calculated by the following formula: gear ratio = motor shaft revolutions / driving shaft revolutions. The values must be set as desired value * 100.

5.3.4.21 6098h Homing method

This object contains the zeroing method used by the device for the homing procedure; the permitted values are:

- 1 = Homing with zero proximity search in the positive direction and then search for the index pulse (zero of the encoder) in the negative direction.
- 2 = Homing with zero proximity search in the negative direction and then search for the index pulse (zero of the encoder) in the positive direction.
- 17 = Homing with zero proximity search in the negative direction.
- 18 = Homing with zero proximity search in the positive direction.
- 37 = Homing without zero proximity, the actual position will be zero position.
- -1 = Homing on negative torque and index pulse (zero of the encoder): search in the negative direction for the current limit and then go right until zero encoder is on.
- -2 = Homing on positive torque and index pulse (zero of the encoder): search in the positive direction for the current limit and then go right until zero encoder is on.
- -3 = Homing on negative torque: search in the negative direction for the current limit and then stops there.
- -4 = Homing on positive torque: search in the positive direction for the current limit and then stops there.

5.3 Object dictionary

5.3.4.22 6099h Homing speeds

This object contains the speed values used during the zero procedure:

- Fast homing speed = speed used to search for the zero proximity
- Slow homing speed = speed used to depart from the zero proximity and to find the index pulse

5.3.4.23 609Ah Homing acceleration

This object shall indicate the configured acceleration and deceleration to be used during homing operation.

5.3.4.24 60FFh Target velocity

This object contains the target velocity during the velocity profile operation.

5.3.5 Manufacturer custom objects

In Table 5.19 are listed the manufacturer custom objects.

Table 5.19: Manufacturer custom object.

ID	Sub	Description	Type	Access	PDO Mapping	Default Value
2001h	0	Feed converter Highest sub-index supported	U8	RO		2
	1	Numerator	U32	RW		1
	2	Denominator	U32	RW		1
2002h	0	Input Status	U32	RO	TPDO	0
2003h	0	Output Status	U32	RO	TPDO	0
2004h	0	Homing Ok	U8	RO	TPDO	0
2006h	0	Warnings	U16	RO		0
2010h	0	Limits enable	U8	RW		0
2011h	0	PID parameters Highest sub-index supported	U8	RO		5
	1	Pid Selection	U16	RW		1
	2	Kp Position	U16	RW		1
	3	Kp Speed	U16	RW		10000
	4	Ki Position	U16	RW		0
	5	Ki Speed	U16	RW		10
2012h	0	Profile parameters Highest sub-index supported	U8	RO		2
	1	Profile check	U8	RW		1
	2	Profile timeout	U16	RW		50
2013h	0	Homing torque limit	U8	RW		10
2014h	0	Actuator type	U8	RW		0
2015h	0	Torque limit enable	U8	RW		1

5.3.6 Manufacturer custom objects descriptions

In the following sections are described the manufacturer custom objects.

5.3 Object dictionary

5.3.6.1 2001h Feed converter

This parameter changes the unit of measurement used for the position, the speed and acceleration used to read and write dictionary objects and PDOs. The default units of measurement are:

- Position [mm]
- velocity [mm/s]
- Acceleration [mm/s²]

It is possible to change the unit of measurement with this object:

New unit = default unit · Numerator / Denominator

For example, to set the unit of measurement to inches: Numerator = 100, Denominator = 254.

5.3.6.2 2002h Input status

This read-only parameter contains the status of the inputs present in the drive. The bit representation is described in Table 5.20.

Table 5.20: Input status bit.

Bit 31-4	Bit 3	Bit 2	Bit 1	Bit 0
Reserved	Proxy	in3	in2	in1

5.3.6.3 2003h Output status

This read-only object contains the status of the output present in the drive. The bit representation is described in Table 5.21.

Table 5.21: Output status bit.

Bit 31-1	Bit 0
Reserved	out1

5.3.6.4 2004h Homing ok

This read-only object contains the homing status.

- 1 = Homing done.
- 0 = Homing not performed.

5.3.6.5 2006h Warnings

This read-only object contains the possible warnings coded with 1 bit for each warning type. A complete descriptions of every bit is described in the Table 5.36

5.3.6.6 2010h Limits enable

This object enable the check of the limits value (target, acceleration, deceleration etc.)

- 0 = Software Limits check disabled.
- 1 = Software Limits check enabled.

5.3 Object dictionary

5.3.6.7 2011h PID parameters

This object let to be possible to set main PID parameters: Sub-index 1 contains the PID type value that could be

- 0 = PID default
- 1 = PID low
- 2 = PID medium
- 3 = PID high
- 4 = PID custom

the next subindex are only for PID custom:

Sub-index 2 contains the KP position value

Sub-index 3 contains the KI position value

Sub-index 4 contains the KP speed value

Sub-index 5 contains the KI speed value

5.3.6.8 2012h Profile parameters

Sub-index 1 Enable or disable the check of the actual rotor position, with respect to the target imposed.

Sub-index 2 Profile check timeout measured in ms. If "Profile check" is enabled, this parameters represents the time after which a warning is set, if the actual rotor position does not match the imposed one.

5.3.6.9 2013h Homing torque limit

This parameter set the threshold current value when the DRVI have to execute a homing procedure. The value is set as a percent of the I^2T value (I^2T value depends of the size of the motor and can't be modified)

5.3.6.10 2014h Actuator type

This parameter set the type of the actuator. The possible values are:

- 0 = Only motor
- 7 = Custom Actuator

5.3.6.11 2015h Torque limit enable

This object enable the check of the maximum allowed torque value (the limit value must be set with the Target torque parameter)

- 0 = Torque limit check disabled.
- 1 = Torque limit check enabled.

5.4 Profile position

5.4 Profile position

The drive provides operations for the profile position described in the CiA 402 specifications. For general profile position description please refer to Section 4.1.2. This drive operation mode requires a specific target position, setting the velocity, acceleration and deceleration, with which to reach the target position. The target cannot be changed during a movement, the movement in progress must be terminated or interrupted before being able to set a new target.

To enable this operation, set the operating mode to value 1 via object 6060h "Modes of operation" and check that the drive is effectively in the correct status with object 6061h "Modes of operation display".

In this operating mode the **controlword** (profile-specific) bits become:

- Bit 4 "new set point" = this bit must be raised to indicate the start of the movement to reach the target. The drive response on the statusword is through bit 12.
- Bit 6 "abs / rel" = this bit is used to indicate the type of movement that must be done, 0 = absolute position movement, 1 = relative position movement.

At the end of the movement the **statusword** bits become:

- Bit 10 "target reached" = this bit indicates the achievement of the target at the end of the positioning.
- Bit 12 "set-point reached" = this bit indicates that the positioning is in progress and it remains high until positioning command has been completely acquired by the drive. When it is low it indicates the drive is ready to receive a new command.

The dictionary objects related to this operating profile are described in Table 5.22.

Table 5.22: Profile position objects.

Object	Object description
6060h	"mode of operation" select the operating mode
607Ah	"target position" target position to be reached
6081h	"Profile velocity in positioning mode" velocity of the movement
6083h	"profile acceleration" acceleration of the movement
6084h	"profile deceleration" deceleration of the movement

The start and stop of the movement is always controlled by bit 2 of the "controlword": transition of bit 4 from 0 to 1 will start the movement, whilst bit 8 can be used to stop the movement immediately.

5.5 Profile velocity

5.5 Profile velocity

The drive provides the operations for the velocity profile described in the CiA 402 specifications. For general profile velocity description please refer to Section 4.1.2.

This drive operation mode requires a specific target velocity, acceleration and deceleration: once the velocity target is set, the motor accelerates until the target speed is reached and then maintains the required velocity until a new request is made.

To enable this operation, set the operating mode to value 3 via object 6060h "Modes of operation" and check that the drive is effectively in the correct status with object 6061h "Modes of operation display".

In this operating mode the **controlword** (profile-specific) bits become:

- Bit 4 "new set point" = this bit must be raised to indicate the start of the movement to reach the target. The drive response on the statusword is through bit 10.
- Bit 8 "halt bit" = this bit is used to stop immediately the movement 0 = continue the movement, 1 = stop the movement.

The **statusword** is updated as follows:

- Bit 10 "target reached" = with the "halt" bit equal to zero this bit indicates the achievement of the velocity target, with the "halt" bit equal to one this bit indicates if motor is stopped: 1 = motor stopped 0 = motor being decelerated.
- Bit 12 "Speed" this bit indicates if motor is stopped: 1 = motor stopped 0 = motor moving.

The dictionary objects related to this operating profile are described in Table 5.28.

Table 5.23: Profile velocity objects.

Object	Object description
60FFh	"Target velocity" set a velocity target and then start the movement
6083h	"Profile acceleration" set the acceleration profile
6084h	"Profile deceleration" set the deceleration profile
606Fh	"Velocity threshold" set the zero velocity threshold (motor stopped)
6070h	"Velocity threshold time" set the minimum time for zero velocity

5.6 Profile torque

The drive provides the operations for the Profile Torque mode described in the CiA 402 specifications. For general torque profile description please refer to Section 4.1.2.

To enable this operation, set the operating mode to value 4 via object 6060h "Modes of operation" and check that the drive is effectively in the correct status with object 6061h "Modes of operation display".

In this operating mode the **controlword** (profile-specific) bits become as shown in Figure 5.4 and in Table 5.25.

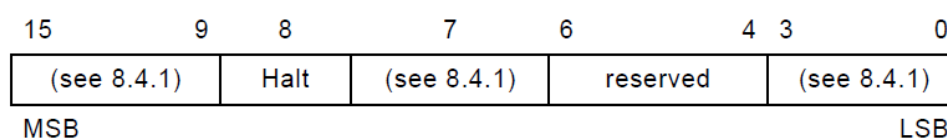

Figure 5.4: Control word for profile torque mode.

5.7 Homing mode

Table 5.24: Definition of bit 8.

Bit	Value	Definition
8	0	The motion shall be executed or continued
	1	

The **statusword** is updated as shown in Figure 5.5 and in Table 5.25.

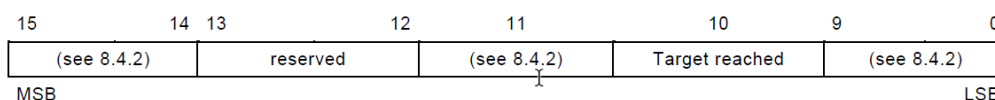

Figure 5.5: Status word for profile torque mode.

Table 5.25: Definition of bit 10.

Bit 10	Value	Definition
10	0	Halt (bit 8 in controlword) = 0: Target torque not reached Halt (bit 8 in controlword) = 1: Axis decelerates
	1	Halt (bit 8 in controlword) = 0: Target torque reached Halt (bit 8 in controlword) = 1: Velocity of axis is 0

5.7 Homing mode

The drive provides the operations for the Homing mode described in the CiA 402 specifications. For general homing description please refer to Section 4.1.2. Homing is the procedure by which the motor searches for the zero position, identified by the zero proximity position. From this position the counting of all movements starts.

To enable this operation, set the operating mode to value 6 via object 6060h "Modes of operation" and check that the drive is effectively in the correct status with object 6061h "Modes of operation display".

In this operating mode the **controlword** (profile-specific) bits become as shown in Figure 5.6 and in Table 5.27.

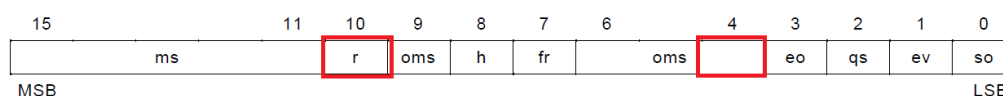

Figure 5.6: Control word for homing mode.

Table 5.26: Definition of bit 4 and bit 10.

Bit	Value	Definition
4	0	do not start homing
	1	start homing
10	0	enable bit 4
	1	stop the motor movement

The **statusword** is updated as shown in Figure 5.7 and in Table 5.27.

5.8 Jog mode

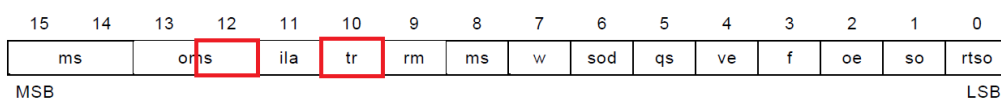

Figure 5.7: Status word for homing mode.

Table 5.27: Definition of bit 10 and bit 12.

Bit 12	Bit 10	Definition
0	0	Homing procedure is in progress or turn on condition
1	0	Homing is attained, but target is not reached
0	1	Homing procedure is completed successfully

The 2004h "Homing Ok" dictionary object contains the drive homing status: 0 means that no homing has been performed, 1 homing has been performed (ready for movement commands). To setup the execution movement for the homing procedure, the objects listed in Table 5.28 must be configured.

Table 5.28: Homing objects.

Object	Object description
6060h	"Mode of operation" to set the homing mode
609901h	"Homing velocity fast speed" proximity search velocity
609902h	"Homing velocity slow speed" proximity out velocity
6098h	"Homing method" the number of the type of homing that must be performed
609Ah	"Homing acceleration" define the acceleration/deceleration to be used during the homing movement
607Ch	"Home offset" offset to be applied to the physical zero position to move the motor zero
6071h	"Target torque" torque limit to be reached in case of a Torque Homings has been requested
2013h	"Homing torque limit" in case of a Torque Homings it is a percent used to limit the currents of the motor

The drive includes nine possible homing methods: two based on the search direction of the zero proximity, five without the zero proximity and two based on the combination of the proximity sensor and the zero of the relative encoder. Homing types and their relative correspondence with the mode of operation described in Chapter 4, is listed in Table 5.29. For general description of homing modes of operation, please refer to Chapter 4.

Table 5.29: Homing methods.

Homing number	Mode of operation
1	Proximity homing: negative direction + zero encoder
2	Proximity homing: positive direction + zero encoder
17	Proximity homing: negative direction
18	Proximity homing: positive direction
37	Positioning homing
-1	Torque homing: negative direction + zero encoder
-2	Torque homing: positive direction + zero encoder
-3	Torque homing: negative direction
-4	Torque homing: positive direction

5.8 Jog mode

5.8 Jog mode

This operation mode makes it possible to move the drive in speed mode using 2 bits of the controlword. To enable this operation, set the operating mode to value -1 via object 6060h "Modes of operation" and check that the drive is effectively in the correct status with object 6061h "Modes of operation display".

In this operating mode the **controlword** (profile-specific) bits become as shown in Figure 5.8:

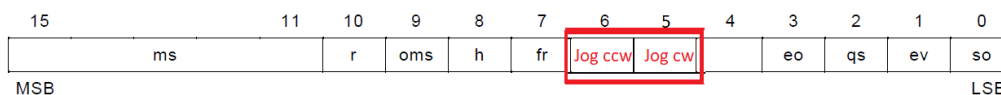

Figure 5.8: Control word for jog mode.

Table 5.30: Control word - definition of bit 5 and bit 6.

Bit 6	Bit 5	Definition
0	0	Stop (zero speed)
1	0	Clockwise rotation
0	1	Counter-clockwise rotation
1	1	Invalid command (previous state persists)

The **statusword** is updated as shown in Figure 5.9:

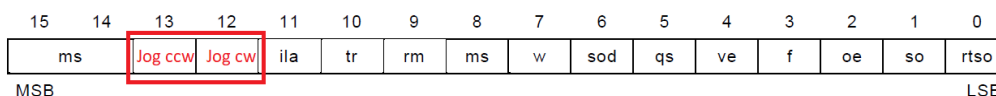

Figure 5.9: Status word for jog mode.

Table 5.31: Status word - definition of bit 12 and bit 13.

Bit 13	Bit 12	Definition
0	0	Jog OFF
0	1	Jog movement Clockwise
1	0	Jog movement Counter-clockwise
1	1	Forbidden state

To configure the execution jog movements, the following objects must be configured as shown in Table 5.32:

Table 5.32: Jog mode objects.

Object	Description
6060h	"Mode of operation" to set the Jog mode
60FFh	"Target velocity" set the target speed used during jog movements
6083h	"Profile acceleration" set the acceleration to be used during the jog movements
6084h	"Profile deceleration" set the deceleration to be used during the jog movements

5.9 Diagnostic behavior

The drive handles both errors and warnings. The difference between the two is that warnings do not impact on the drive operation (they are just signaled), whilst errors cause the motor to stop. Both errors and warnings remain latched even if the error or warning condition disappear. To reset the warning and error condition, the proper reset command must be given. The drive status can be monitored by the status LED (refer to Section 3.4). The only warnings that auto-reset are the "homing missing" and the "command refused" ones. Errors are divided into two categories: hard and soft. Soft errors are considered less severe and they cause a controlled stop of the motor rotation by triggering the command QUICK_STOP.

Soft errors are:

- Temperature motor limit
- Temperature drive limit
- Homing execution error
- Fieldbus disconnection

All the others (see Table 5.34) are hard errors and they cause the power drives to be turned off, hence the motor finishes its rotation in idle state, that is, with no control applied.

5.9.1 Emergency Object

When the drive is in error state, it sends this information through the asynchronous emergency message. The emergency COB-ID is defined using the 1014h "COB-ID EMCY" object.

Every error has its own code (Errcode); these codes are divided in sub-errors, for example into current errors, voltage errors, etc.

The emergency telegram is structured as shown in Table 5.33.

Table 5.33: Emergency message.

Byte 0-1	Byte 2	Byte 3	Byte 4-7
Errcode	reserved	Manufacturer parameter	reserved

- Byte 0 and 1 contain the Errcode value (see Section 5.9.2)
- Byte 3 has as a sub-code optional parameter

5.9.2 Errcode codes

In Table 5.34 are shown the possible ErrorCodes values and descriptions.

5.9 Diagnostic behavior

Table 5.34: Errcode and manufacturer parameters description.

Errcode value	Manufacturer parameter	Description
0000h	0	Drive is not in error state
2310h	0	Over current error
2310h	11	I ² T fault
3110h	0	Over voltage error VBUS (> 80V)
3110h	1	Over voltage error VLOG (> 29V)
3120h	0	Under voltage error VBUS (< 10V)
3120h	1	Under voltage error VLOG (< 16V)
4210h	0	Over temperature motor error (> 100°C)
4210h	1	Over temperature drive error (> 100°C)
5120h	0	VEXT missing
5530h	0	Non volatile memory fault
5540h	0	Error HW Enable is not present (STO)
6100h	0	Control fault
6120h	0	Software Limits exceed
7305h	0	Encoder fault
8120h	0	CAN in error passive
8210h	0	PDO data length too short
8220h	0	PDO data length exceeded
8613h	13	Homing execution error

5.9.3 Error dictionary objects

The dictionary objects related to the errors management are:

Table 5.35: Error dictionary objects.

Object	Description
603Fh	"Errorcode", it provides the error code of the last error occurred
1003h	"Pre defined error" holds errors that have occurred on the device

To erase the errors and try to restore the drive to operational status is necessary to:

- Write 0 in the 100300h OR set bit7 of the ControlWord to 1
- Make the NMT state machine transition to Ready to switch on.
- Make the NMT state machine transition to Switched on.
- Make the NMT state machine transition to Operation enable.

5.9.4 Warnings

The drive can manage warnings information in the following way:

- When a warning condition happens, the bit 7 of the statusword is set.

5.10 NMT protocol description

- The user can ask to the drive to send the coded information of the active warnings, reading the object 2006h.
- The procedure to erase the warnings is the same as the errors.

In Table 5.36 are shown the possible warning values and descriptions of the bits read in the object 2006h.

Table 5.36: Diagnostic word description.

Bit	Warnings
0	VDC UVLO (< 20V)
1	VDC OVLO (> 60V)
2	VL UVLO (< 21V)
3	VL OVLO (> 27V)
4	Temperature motor limit (> 75°C)
5	Temperature drive limit (> 75°C)
6	Positive position limit reached
7	Negative position limit reached
8	Homing missing
9	Target speed not reached
10	Target position not reached
11	Command refused
12 ... 15	RESERVED

NOTE: Temperature warnings don't affect the drive functionality, but they indicate the hot surface of the motor and/or the drive.

5.10 NMT protocol description

The NMT services allow to init, start, monitor, reset and stop the CAN nodes. All the NMT services have COB-ID = 0 because they have the highest priority.

Every NMT instruction is composed of two bytes: the first is the code of the NMT command, the second could be the Node-ID of the specific device or 0 if the command is of type broadcast (refer to Table 5.37).

Table 5.37: NMT structure.

Byte 0	Byte 1
Command specifier	Node ID

5.10.1 NMT services for device control

The first byte of an NMT message for device control, the "Command specifier", indicates the NMT service used. These services are transmitted as unconfirmed messages with COB-ID = 0. The possible command codes are listed in Table 5.38.

5.10.1.1 NMT states machine

In Figure 5.10 is shown the NMT states machine.

5.10 NMT protocol description

Table 5.38: NMT command specifiers.

CAN-ID	Command Code	Description
000h	1h + NodeID	Start remote node
	2h + NodeID	Stop remote node
	80h + NodeID	Enter pre-operational
	81h + NodeID	Reset node
	82h + NodeID	Reset communication

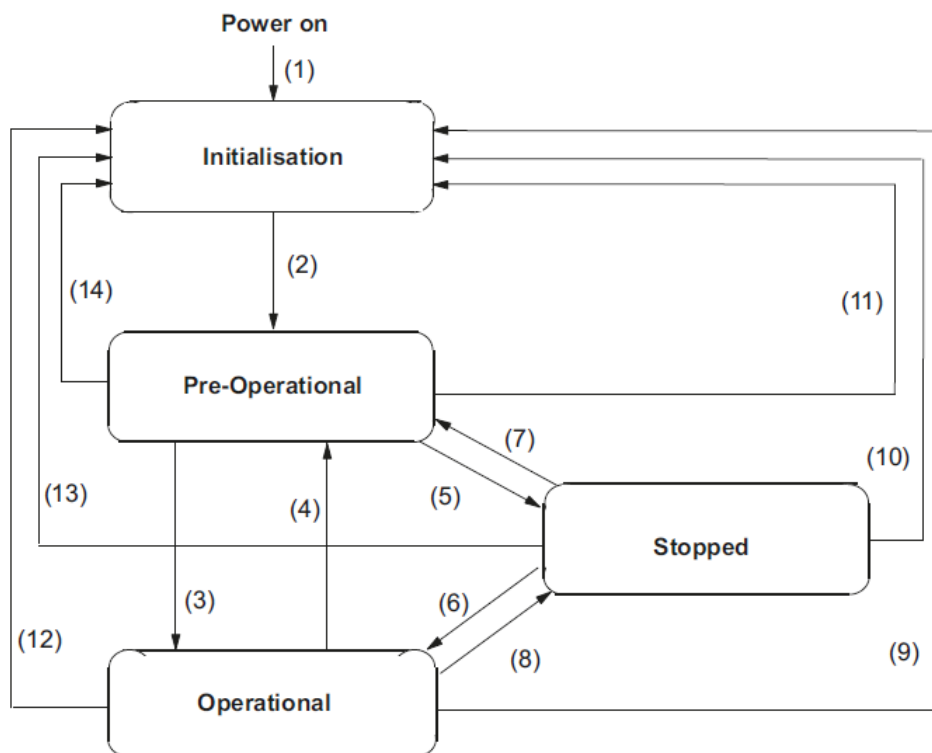

Figure 5.10: NMT states machine.

In Table 5.39 are described the transitions and the commands involved on the state machine.

Table 5.39: Transitions of the state machine.

Transition	Services
(1)	Automatically enter in this state after Power On
(2)	Automatically enter in this state after Initialization
(3), (6)	Start remote node command
(4), (7)	Enter pre-operational command
(5), (8)	Stop remote command
(9), (10), (11)	Reset node command
(12), (13), (14)	Reset communication command

The NMT states has different features, as shown in Table 5.40.

5.10 NMT protocol description

Table 5.40: NMT state features.

State	PDO	SDO	Description
Initialisation	NO	NO	When enter in this state the device sent NMT Bootup message
PreOperational	NO	YES	In this state is possible to send only NMT and SDO messages
Operational	YES	YES	Every type of messages is possible. When enter in this state an NMT message is sent with code 0x7xx + 05h
Stopped	NO	NO	Only NMT messages are possible in this state. When enter in stopped status, an NMT message is sent with code 0x7xx + 04h

5.10.2 NMT services for device monitoring

The communication state between the DRVI devices and the NMT master (e.g.: PLC) can be monitored using:

- Node Guarding
- Heartbeat

5.10.2.1 Node Guarding

The Node Guarding protocol can be used to monitor the communication between master and slaves (see Figure 5.11). Master checks the slave sending cyclical NMT messages (Guard Time) and it expects a NMT response from slave with a data byte that contains the NMT status (bit 0 ... 6) and a toggle bit that must be inverted every message.

Slave checks that the master sends a periodic NMT message within a certain time (Life time) and in case it is not received, it sends an error message.

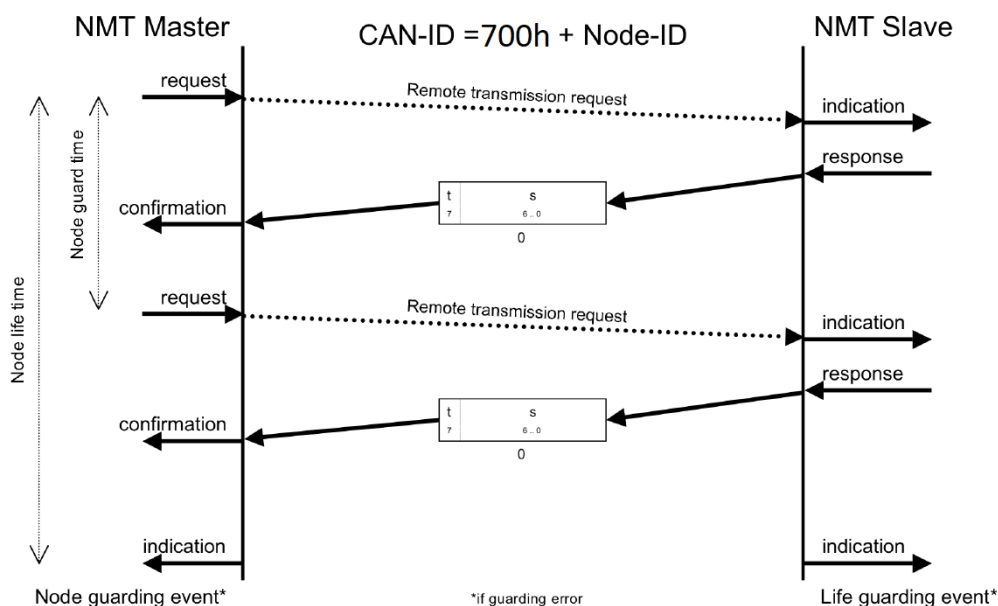

Figure 5.11: Node guarding example.

The protocol uses two objects to setup the timings, as shown in Table 5.41.

5.10 NMT protocol description

Table 5.41: Node guarding objects.

ID	Sub	Description
100Ch	0	Guard time
100Dh	0	Life time factor

The Life time is calculated according to the following formula:

$$\text{Life time} = \text{Guard time (100Ch)} \times \text{Life time factor (100Dh)}$$

If Guard time and Life time factor are 0, the Node Guarding service is disabled except at boot-up. The possible device response messages are described in the Table 5.42.

Table 5.42: Node guarding slave messages.

COB-ID	Data bit	Value	Description
700h + node-ID	0..6	00h	Boot-up
		04h	Stopped
		05h	Operational
	7	0 / 1	Toggle bit, it changes at each message

5.10.2.2 Heartbeat

The Heartbeat protocol is an optional alternative to the Node guarding: it implies that the devices (Heartbeat producers) sends periodically an NMT message that another device (Heartbeat consumer, it could be typically the PLC) checks that it arrives within a certain time. If not, the Heartbeat consumer generates an error.

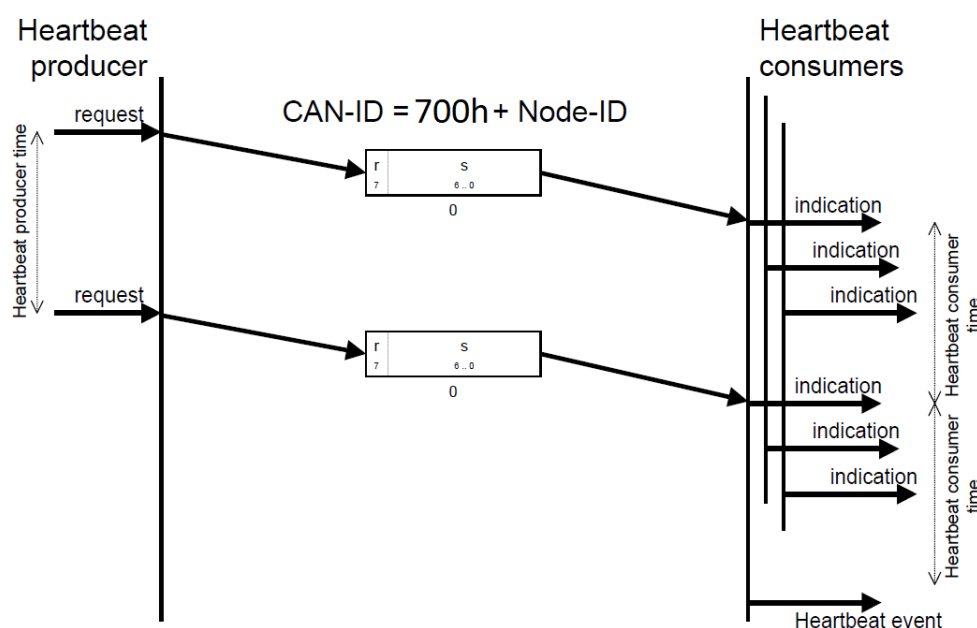

Figure 5.12: Heartbeat example.

5.10 NMT protocol description

The protocol uses the object 1017h to setup the frequency time at which the device send its Heartbeat message: if its value is 0, the Heartbeat protocol is disabled. The Heartbeat producer sends periodically messages that are the same described in Table 5.42. "Heartbeat" monitoring starts as soon as the time interval of the producer is greater than zero.

5.11 Inputs GPIO

5.11 Inputs GPIO

The INPUTS_GPIOs status present on the GPIO connector (refer to Section 3.3.2), can be checked according to the bitmask described in Table 5.43. A "0" value indicates an input LOW state while a "1" value indicates an input HIGH state.

Table 5.43: Input GPIO bitmask.

Bit	Description
0	IN1
1	IN2
2	EXT PROXY INPUT
3	PROXY INPUT

The inputs status can be read with the CANopen object 0x2002 Input Status.

5.12 Outputs GPIO

The status of the OUTPUT_GPIO present on the GPIO connector (refer to Section 3.3.2) can be changed according to the rule in Table 5.44.

Table 5.44: Output GPIO bitmask.

Bit	Value	Description
0	0	OUT LOW
	1	OUT HIGH

The output status can be modified with the CANopen object 0x2003 Output Status.

Uvix

6.1 Introduction

Camozzi's proprietary environment, called UVIX, allows the user to monitor and configure all new generation Camozzi devices (*Camozzi Smart Devices*) that support connection to it. Devices can be connected to UVIX via USB. This system has been implemented with a web-based architecture so that information can be accessed straightforwardly using a browser. Monitoring consists of displaying all the device variables, whether they relate to operation, diagnostics, or parameterization.

For details on the UVIX architecture, its installation, and general operations, see the [UVIX Manual](#).

6.2 General information

6.2 General information

The devices connected to the UVIX are displayed in a tree diagram ❶ consisting of *Device Groups*, *Family* and *Devices*. Select one of the components to view in the main window ❷ all the information on the various devices and perform configuration operations or manual commands.

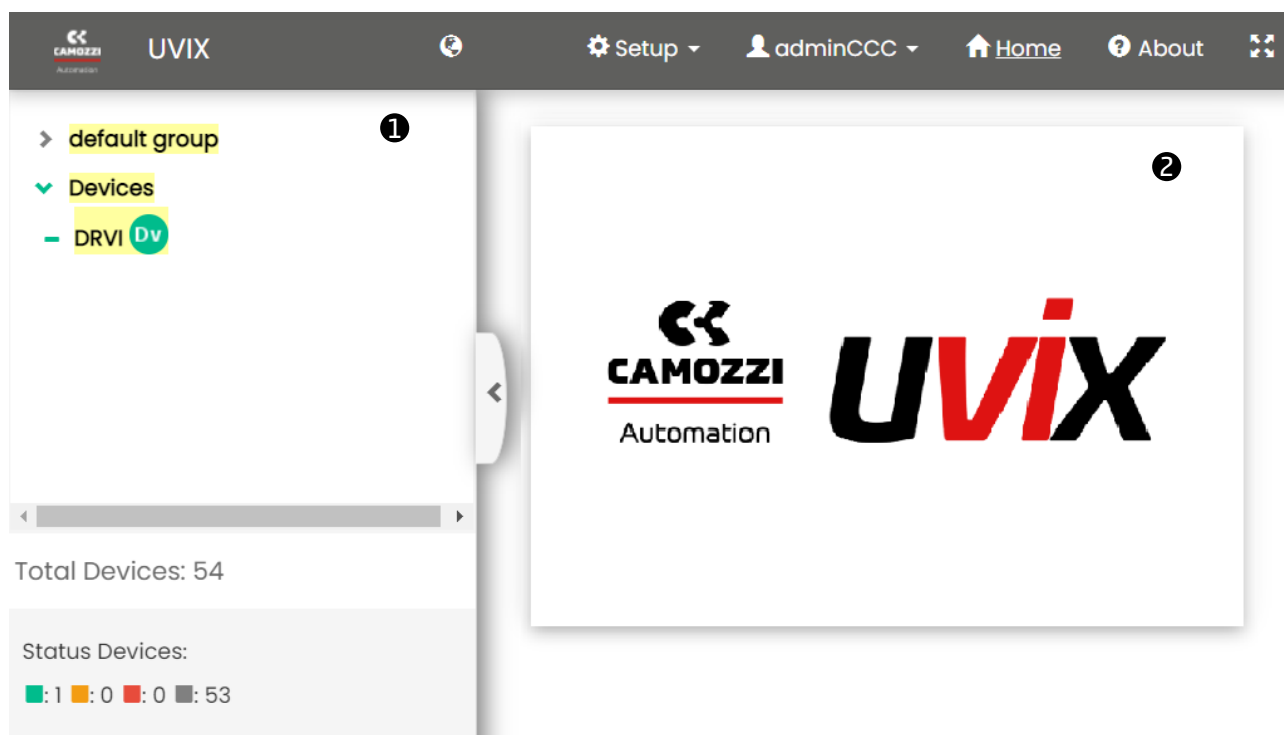

Figure 6.1: Main page of the UVIX interface.

Select the DRVI device to view the general status information and details (variables, alarms, and commands). Furthermore, it is possible to set the DRVI parameters and to communicate with the device in real-time (*Commissioning*).

6.3 Status information

6.3 Status information

- ❶ Image of the DRVI series.
- ❷ Assigned name of the device.
- ❸ Identification number of the device (17 chars).
- ❹ Family name of the device: *Series Integrated Foc Drive*.
- ❺ Subtype of the device family: *Drvi Stepper/Brushless Motor*.
- ❻ Firmware version.
- ❼ Date and time of the last data transmission.
- ❽ General status of the device: ● Not available, ● Ok, ● Warning, ● Alarm.
- ❾ Operational status of the device:
 - *Work*: normal operation.
 - *Manual*: manual operation.
- ❿ Connection status: ● Ok, ● Offline.
- ⓫ Fieldbus communication: Profinet/EtherCAT/CANopen.
- ⓬ Communication status of the Fieldbus: ● Ok, ● Offline.
- ⓭ Fieldbus configuration (par. ??).
- ⓮ DRVI parameters configuration (par. 6.5).
- ⓯ Commissioning device (par. 6.6).

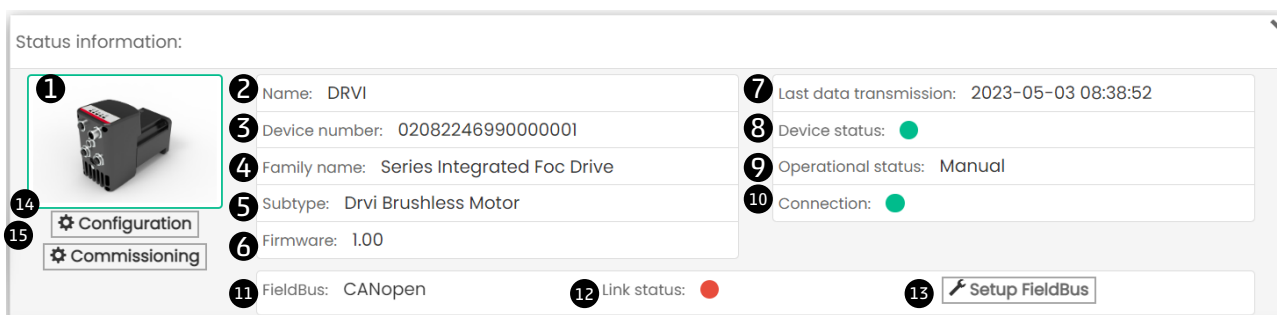

Figure 6.2: Main page of the UVIX interface.

6.4 Details



6.4.1 Variables

The first tab of the details page deals shows the variables that are monitored by the DRVI device as shown in Figure 6.3.



- Motor Size: *Nema 17, Nema 23, Nema 24.*
- Brake: *Present or Not present.*
- STO: *Present or Not present.*
- Actuator type:
 - *Only motor*
 - *Custom actuator*
- V Logic: supply voltage for the device controller circuit board. Without this supply voltage, the device is turned off.
- V Bus: bus voltage in.
- T Motor: motor temperature in °C.
- Servo state: *On or Off.*
- Mode of operation:
 - *Homing*
 - *Speed*
 - *Relative positioning*
 - *Absolute positioning*
 - *Torque*
- Busy state: *True or False.*
- Homing state: *Present or Not present.*
- Actual pos: actual position measured in angular degrees or mm.
- Actual vel: actual velocity measured in RPM or mm / s.
- Actual torque: actual torque (current) measured in mA.
- Total stroke: total stroke measured in m.
- Total time on: total time on measured in hours.
- Total time off: total time off measured in hours.
- Total time run: total time run measured in hours.
- Power: power consumption measured in watt hour.
- Output GPIO: *On or Off.*
- Input 1: *On or Off.*
- Input 2: *On or Off.*
- Input proxy external: *On or Off.*
- Input proxy homing: *On or Off.*

6.4.2 Alarms

The second tab on the details page displays possible DRVI alarms as shown in Figure 6.4.

- Error alarms: *Alarm active*  , *Alarm not active*  .
 - *VBUS under voltage.*

6.4 Details

- VBUS over voltage.
- VLOG under voltage.
- VLOG over voltage.
- Motor temperature.
- Drive temperature,
- Over current.
- Fault in control loop.
- Encoder fault.
- Non-volatile memory fault.
- Energy dissipation fault.
- STO fault.
- Homing fault.
- Warning alarms: *Alarm active* , *Alarm not active* .
- VBUS under voltage.
- VBUS over voltage.
- VLOG under voltage.
- VLOG over voltage
- Motor temperature.
- Drive temperature.
- Homing not done.
- Target speed not reached.
- Target position not reached.
- Invalid command.
- Position limit reached.

6.4 Details

Details: ▼

▬ Variables
🔔 Alarms
📡 Commands

Name	Value
Motor size	Nema 23
Brake	Not present
STO	Not present
Actuator type	Only motor
V Logic	23.3 V
V Bus	23.7 V
T Motor	27.8 °C
Servo state	On
Mode of operation	Homing

Figure 6.3: Section for the variables monitored by the DRVI device.

Details: ▼

▬ Variables
🔔 Alarms
📡 Commands

Event Name	Status ▼	Event Onset
Drive temperature	🟢	
Over current	🔴	
Fault in control loop	🔴	
Encoder fault	🔴	
Non-volatile memory fault	🔴	
Energy dissipation fault	🔴	
VBUS under voltage	🟡	
VBUS over voltage	🟡	
VLOG under voltage	🟡	

Figure 6.4: Section for the alarms monitored by the DRVI device.

6.4 Details

6.4.3 Commands

The third tab of details on the DRVI device shows the commands that can be sent via UVIX to the device. The *Manual Mode* command allows you to control the system manually from UVIX, sending configuration parameters to the DRVI. In manual mode, it is possible to reset the alarms ❶, to set the digital output ❷, to start or stop the motor movement ❸, and to switch on/off the servo ❹. The history of the commands sent to the DRVI since the communication with UVIX was started can be viewed under Last Commands ❺.

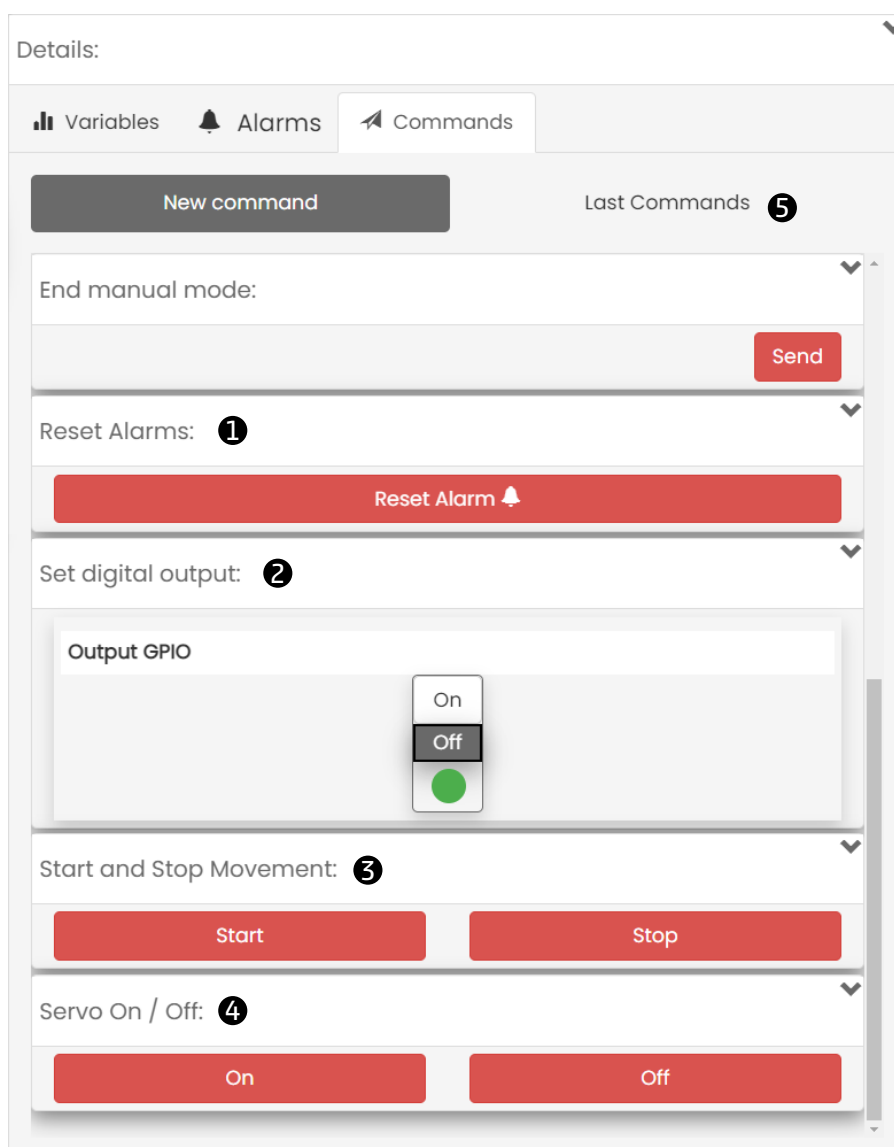

Figure 6.5: Section for the commands managed by the DRVI device.

6.5 Configuration

6.5 Configuration

From the status information page, you can configure certain operating-related parameters of the DRVI: actuator, motion and communication. All these parameters can be stored into the non volatile memory of the drive by clicking the buttons "Send" and subsequently "Save on device".

6.5.1 Actuator

In the actuator section it is possible to set the following parameters:

- ❶ The type of actuator:
 - *Only motor*
 - *Custom Actuator*
- ❷ Gear ratio. If a gear is placed between the drive and the actuator, you can use this parameter to apply an automatic scale of the target (i.e.: profile parameters are multiplied by the gear ratio value).

The following items are software limits, that can be used to restrict the profile parameters:

- ❸ Actuator screw pitch measured in mm / round. This parameter allows the conversion to linear measurement units, when an actuator is connected to the drive.
- ❹ Actuator limits (if ON, it enables to modify the limit values).
- ❺ Actuator minimum stroke measured in mm (such value must be lesser than ❻).
- ❻ Actuator maximum stroke measured in mm (such value must be greater than ❺).
- ❼ Actuator max speed measured in mm / s.
- ❽ Actuator max acceleration measured in mm / s².
- ❾ Actuator max deceleration measured in mm / s².

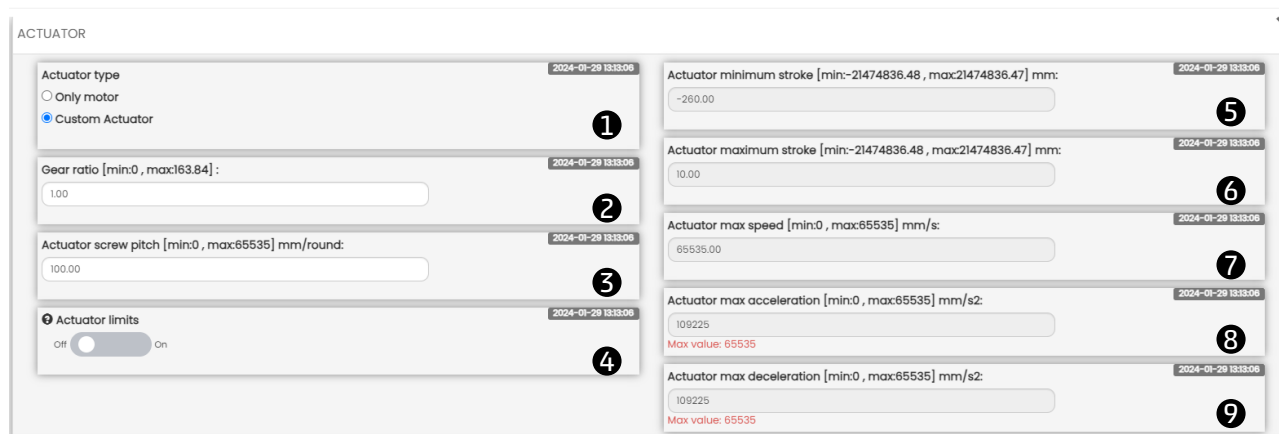

Figure 6.6: Section for actuator configuration.

6.5.2 Motion

In the motion section is possible to set the follows parameters:

- ❿ Profile check: *No* or *Yes*. Enable or disable the check of the actual rotor position, with respect to the target imposed.
- ⓫ Direction of movements: *standard* or *inverse* (with respect to convention, see Paragraph 5.1).

6.5 Configuration

- 11 Profile check timeout measured in ms. If "Profile check" is enabled, this parameters represents the time after which an error is returned, if the actual rotor position does not match the imposed one.
- 12 Quick stop deceleration measured in mm / s².
- 13 Hardware jog mode *No* or *Yes*. Enable or disable the jog mode.

MOTION

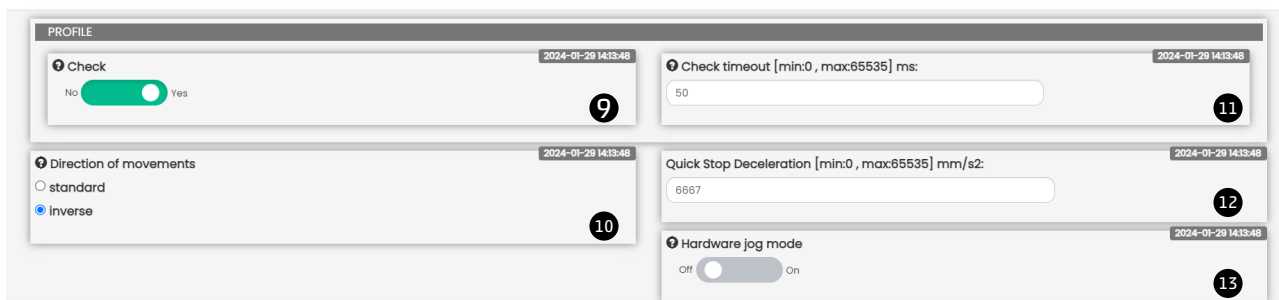

Figure 6.7: Section for motion configuration.

6.5.3 Communication

In the communication section it is possible to set the data endianness used by the fieldbus 13 : *little endian* or *big endian*.

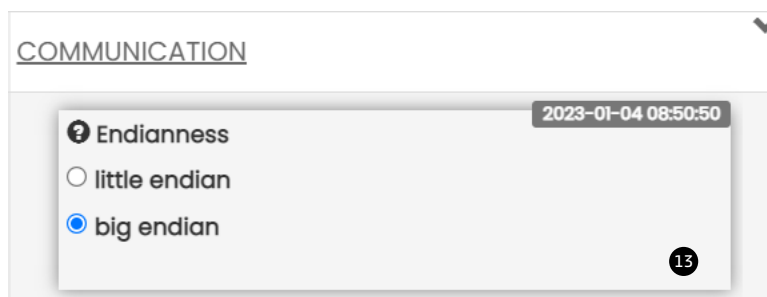

Figure 6.8: Section for communication configuration.

6.5.4 GPIO

In the GPIO section it is possible to set the polarity of the I/O.

GPIO



Figure 6.9: Section for I/O polarity.

6.6 Commissioning

6.6 Commissioning

From the commissioning page it is possible to move the drive, as well as configure some of its parameters. Homing parameters and PID configuration can be stored into the non volatile memory of the drive by clicking the buttons "Send" and subsequently "Save on device".

6.6.1 DRVI states

- ❶ States of the DRVI: it is possible to watch the state of the DRVI, the state of the inputs, set the state of the output and if a fault is active
- ❷ Variables measured in fast mode.
- ❸ Command of the manual mode: *Start or End*.
- ❹ Command of the servo: *On or Off*.
- ❺ Mode operation:
 - *None*
 - *Homing*
 - *Speed*
 - *Absolute position*
 - *Relative position*
 - *Torque*
- ❻ Start and stop of the movement: *Start, Stop*.
- ❼ Reset errors and warnings: *Reset Alarm*.

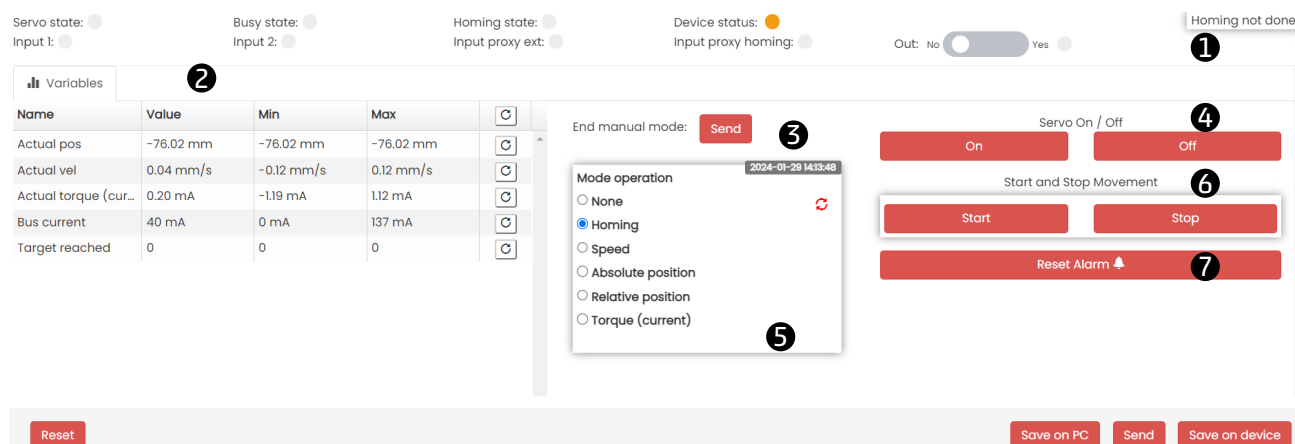

Figure 6.10: Section of the fast mode variables and DRVI states.

In case the mode of operation ❺ is set to Speed, Absolute position, Relative position or Torque the Start and Stop Movement ❻ change as in Figure below.

- ❶ Start Profile1: this is the first target value.
- ❷ Start Profile2: this is the (optional) second target value.
- ❸ Stop: it ends the current movement.
- ❹ Timeout: it set the delay in seconds between profile1 and profile2 target. BE CAREFUL: set a value that is greater than the time elapsed to execute the movement set with profile1 and profile2 target
- ❺ Loop cycle *No, Yes*: it enables the loop of movements between profile1 and profile2 target.

6.6 Commissioning

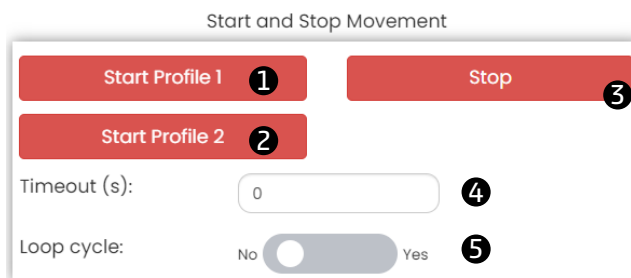

Figure 6.11: Section of the Start and Stop for not Homing modes.

6.6.2 Mode operation parameters

6.6.2.1 Homing

- ⑧ Homing type:
 - Without proximity
 - Proximity left
 - Proximity right
 - Proximity left + zero encoder
 - Proximity right + zero encoder
 - Torque left
 - Torque right
 - Torque left + zero encoder
 - Torque right + zero encoder
- ⑨ Homing speed search measured in RPM or mm / s.
- ⑩ Homing acceleration search measured in RPM / s or mm / s².
- ⑪ Homing deceleration search measured in RPM / s or mm / s².
- ⑫ Homing speed out measured in RPM or mm / s.
- ⑬ Homing acceleration out measured in RPM / s or mm / s².
- ⑭ Homing deceleration out measured in RPM / s or mm / s².
- ⑮ Homing timeout measured in ms.
- ⑯ Homing offset measured in angular degrees or mm.
- ⑰ Torque homing threshold % with respect to the I²T value.

Homing "search" parameters (e.g.: "Homing speed search") are the ones used to find the proximity (or the end of the line), while "out" parameters (e.g.: "Homing speed out") are the ones used to exit from the proximity (or the end of the line).

6.6 Commissioning

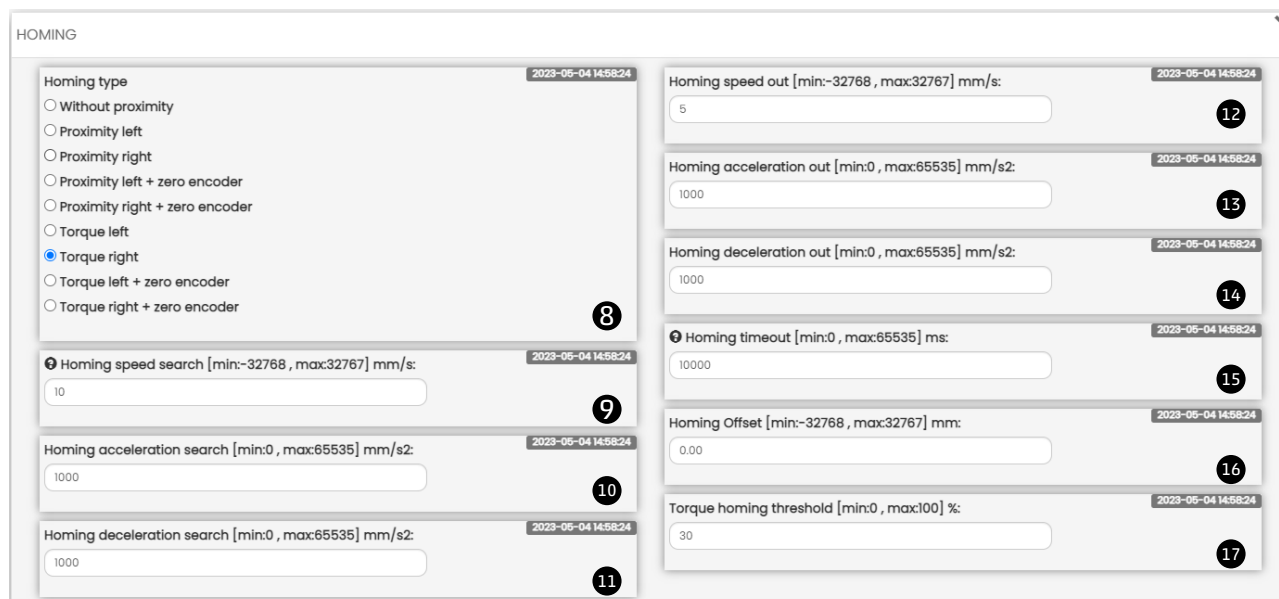

Figure 6.12: Section of the homing parameters.

6.6.2.2 Speed Profile

In the speed profile section it is possible to set the motion profile parameters for the speed control for 2 target speed, profile1 and (optional) profile2. Moreover it is possible to enable/disable the check of the Torque limit and its threshold value in mA:

- ⑧ Target speed measured in RPM or mm / s.
- ⑨ Target acceleration measured in RPM / s or mm / s².
- ⑩ Target deceleration measured in RPM / s or mm / s².
- ⑪ Torque limit enable *No*, *Yes* ².
- ⑫ Target torque limit measured in mA ².

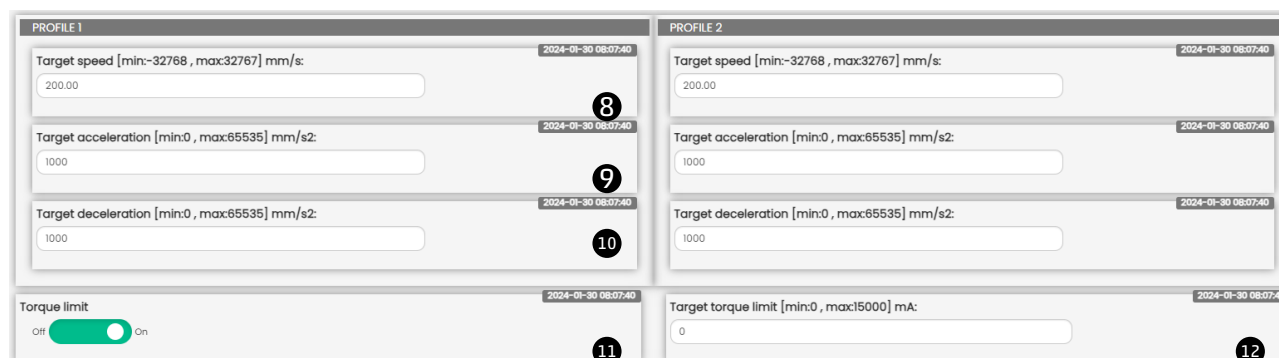

Figure 6.13: Section of the speed profile parameters.

6.6.2.3 Absolute position

In the absolute position section it is possible to set the motion profile parameters for the absolute position control for 2 target positions, profile1 and (optional) profile2. Moreover it is possible to enable/disable the check of the Torque limit and its threshold value in mA:

- ⑧ Target speed search measured in RPM or mm / s.
- ⑨ Target acceleration measured in RPM / s or mm / s².

6.6 Commissioning

- 10 Target deceleration measured in RPM / s or mm / s².
- 11 Target position measured in angular degrees or mm.
- 12 Torque limit enable *No*, *Yes* ².
- 13 Target torque limit measured in mA ².

ABSOLUTE POSITION PROFILE

Figure 6.14: Section of the absolute position profile parameters.

6.6.2.4 Relative position

In the relative position section it is possible to set the motion profile parameters for the relative position control for 2 target positions, profile1 and (optional) profile2. Moreover it is possible to enable/disable the check of the Torque limit and its threshold value in mA:

- 8 Target speed search measured in RPM or mm / s.
- 9 Target acceleration measured in RPM / s or mm / s².
- 10 Target deceleration measured in RPM / s or mm / s².
- 11 Target position measured in angular degrees or mm.
- 12 Torque limit enable *No*, *Yes* ².
- 13 Target torque limit measured in mA ².

RELATIVE POSITION PROFILE

Figure 6.15: Section of the relative position profile parameters.

6.6 Commissioning

6.6.2.5 Torque profile

In the torque profile section it is possible to set the motion profile parameters for the torque (current) control for 2 target positions, profile1 and (optional) profile2:

- ⑧ Target torque (current) measured in mA.
- ⑨ Target slope acceleration measured in mA / s.
- ⑩ Target slope deceleration measured in mA / s.

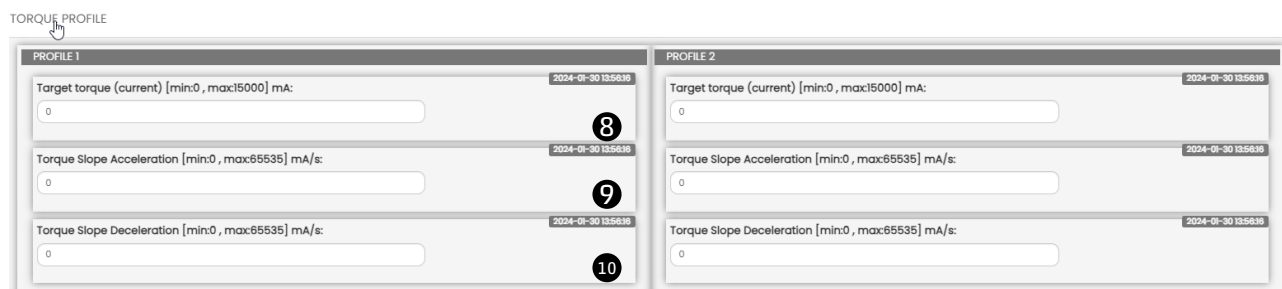

Figure 6.16: Section of the torque profile parameters.

6.6.3 PID

The PID section allows to set the PID values used in motion profiles ⑰ :

- Default
- Low load
- Medium load
- High load
- Custom

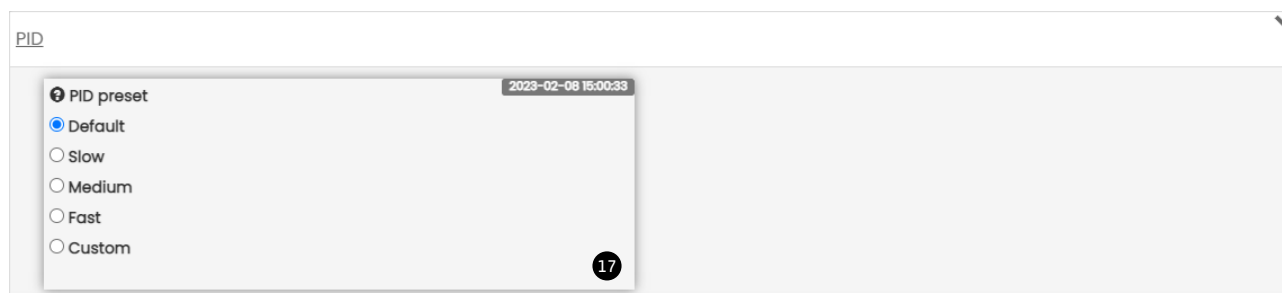

Figure 6.17: Section of the PID control.

PID parameters can be fully customized (see Figure 6.18):

- ⑱ KP speed
- ⑲ KI speed
- ⑳ KP position

6.7 CANopen configuration

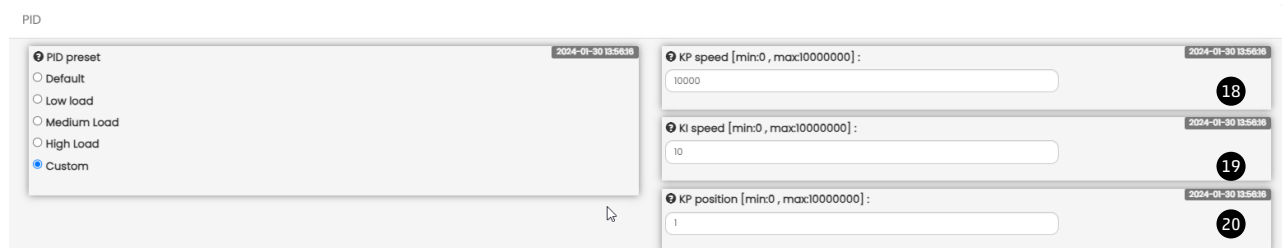

Figure 6.18: Section of the custom PID control.

6.7 CANopen configuration

From the status information page, you can access the window for configuring the CANopen fieldbus parameters: Node Id **1** and the Baud rate **2**. Using the buttons in the bottom bar of the configuration window **3**, the configured parameters can be sent to the module, saved on the PC, saved on the device, or reset to default values.

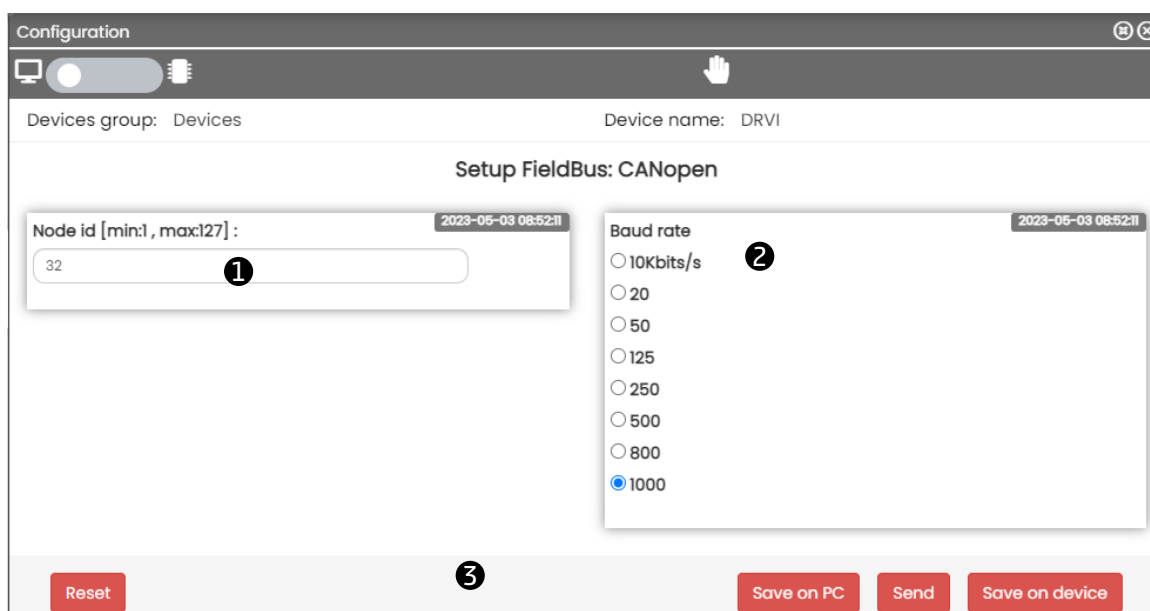

Figure 6.19: Section of the CANopen parameters configuration.

The fieldbus default values are shown in Table 6.1.

Table 6.1: Fieldbus default values.

Parameter	Value
Node id	32
Baud rate	1 Mbit/s

6.8 UVIX USB Gateway

6.8 UVIX USB Gateway

The DRVI can be connected to a PC via a USB cable. This connection - subject to prior installation of UVIX on the PC - allows you to communicate with the module through the Camozzi USB Gateway.

6.8.1 Main page

- ① Toolbar: for managing all the functionalities of the USB Gateway.
- ② USB Gateway Commands: to start or stop the USB Gateway and open the webApp.
- ③ Status: indicates the status of the USB Gateway.
- ④ Open COMs: List of devices currently communicating.
- ⑤ Virtual COM ports available and addresses of TCP connection for the connected COM ports.
- ⑥ Data received from the COM port
- ⑦ Data received on the FEP of the UVIX system.

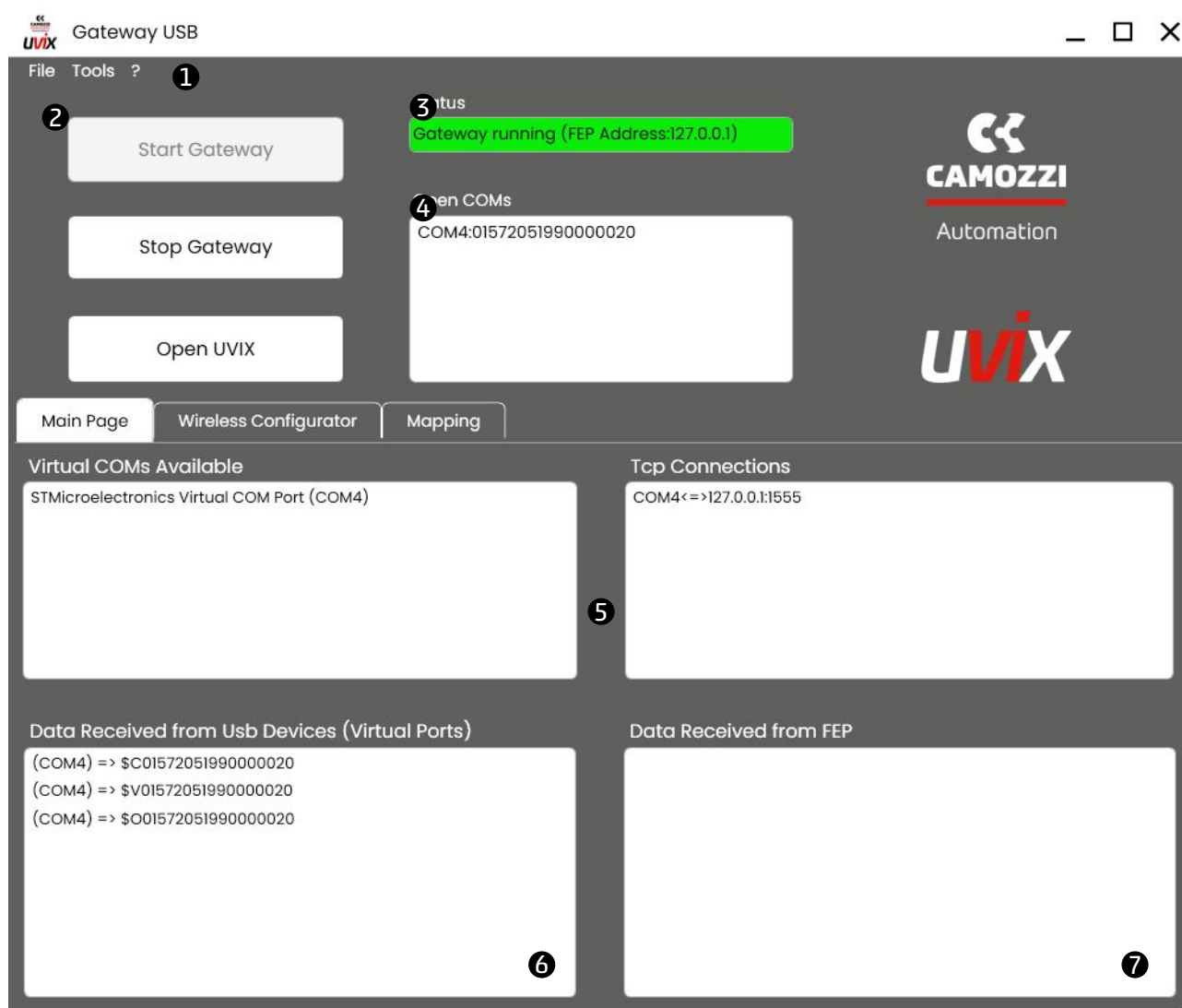

Figure 6.20: Gateway USB.

6.8 UVIX USB Gateway

6.8.2 Firmware update

⚠ Before carrying out this operation, you must contact Camozzi support.

The USB Gateway allows you to update the firmware of the DRVI module through the window found under Tools -> Device Upgrade (NO DFU) **8** (see Figure 6.21).

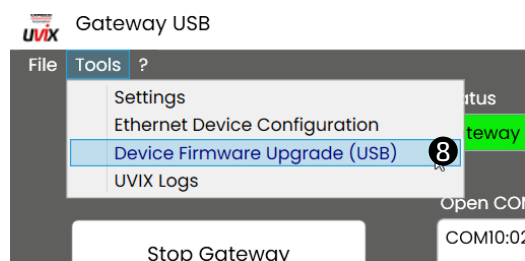

Figure 6.21: Firmware upgrade selection.

The device update window will appear (see Figure 6.22):

- **1** Current FW version.
- **2** Device to be upgraded.
- **3** Button to select binary firmware file.
- **4** New firmware binary file.
- **5** Start upgrade procedure.

Drives Upgrade ✕



Figure 6.22: Firmware upgrade window.

Contacts

Camozzi Automation S.p.A.

REGISTERED OFFICE:

Via R. Rubattino, 81 - 20134 Milano (Italy)
P.IVA IT 03207930177

OPERATIONAL HEADQUARTERS:

Via Eritrea, 20/I - 25126 Brescia (Italy)
Tel. +39 03037921 | Info@camozzi.com
www.camozzi.com

Technical assistance

Tel. +39 030 3792790
service@camozzi.com

Product certification

Information concerning product certifications,
EC standards, conformity declarations and instructions
productcertification@camozzi.com



Automation

