

USE AND MAINTENANCE MANUAL

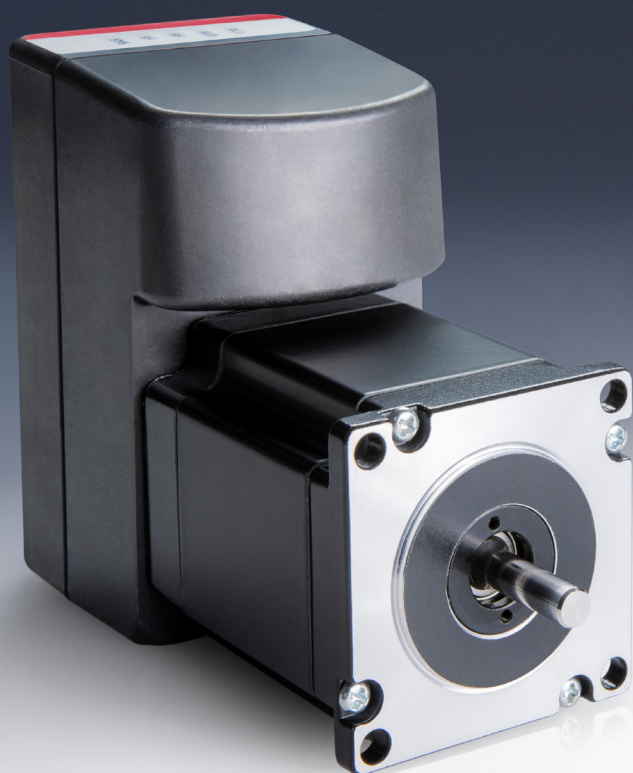

SERIE DRVI ETHERCAT V 1.4



Contents

Chapter 1 General recommendations	1
1.1 Product storage and transport	2
1.2 Use	2
1.3 Limitations of use	2
1.4 Maintenance	2
1.5 Ecological Information	3
Chapter 2 Introduction	4
2.1 About this manual	4
2.2 Unit overview	4
Chapter 3 Technical data	5
3.1 Environmental conditions	5
3.2 Electrical specifications	5
3.2.1 Power supply	5
3.2.2 Wiring	6
3.2.3 Encoder	6
3.3 Electrical connections	7
3.3.1 1 - Power supply	8
3.3.2 2 - GPIO	8
3.3.3 3 - STO (NOT CERTIFIED)	10
3.3.4 4, 5 - Ethernet fieldbus interface	11
3.3.5 6 - USB interface	12
3.3.6 Earth connection	12
3.4 LED indicators	12
Chapter 4 Operation Modes	14
4.1 Fieldbus Modes	14
4.1.1 Speed	14
4.1.2 Positioning	15
4.1.2.1 Relative Positioning	16
4.1.2.2 Absolute Positioning	16
4.1.3 Torque	16
4.1.4 Jog	17
4.1.5 Homing	18
4.1.5.1 Positioning homing	18
4.1.5.2 Proximity homing: negative direction	18
4.1.5.3 Proximity homing: positive direction	18
4.1.5.4 Proximity homing: negative direction + zero encoder	19
4.1.5.5 Proximity homing: positive direction + zero encoder	20

4.1.5.6	Torque homing: negative direction	20
4.1.5.7	Torque homing: positive direction	20
4.1.5.8	Torque homing: negative direction + zero encoder	21
4.1.5.9	Torque homing: positive direction + zero encoder	21
4.1.5.10	Homing offset	22
4.1.6	Other features	23
4.1.6.1	Profile software limits	23
4.1.6.2	Torque limit	23
4.2	Digital Inputs mode	23

Chapter 5 EtherCAT Protocol 25

5.1	Conventions	25
5.1.1	EtherCAT states machine	26
5.2	Configuration via ESI file	27
5.3	Object dictionary	27
5.3.1	Communication Profile - CiA 301 objects	27
5.3.2	CiA 301 objects descriptions	29
5.3.2.1	1000h Device type	29
5.3.2.2	1001h Error register	29
5.3.2.3	1008h Manufacturer hardware name	29
5.3.2.4	100Ah Manufacturer software version	29
5.3.2.5	1018h Identity object	29
5.3.2.6	1600h – 1607h Receive PDO Mapping Parameter	30
5.3.2.7	1A00h – 1A07h Transmit PDO mapping parameter	30
5.3.3	Device Profile - CiA 402 objects	31
5.3.4	CiA 402 objects descriptions	31
5.3.4.1	603Fh Error code	31
5.3.4.2	6040h Controlword	32
5.3.4.3	6041h Statusword	33
5.3.4.4	6060h Mode of operation	34
5.3.4.5	6061h Mode of operation display	34
5.3.4.6	6064h Position actual value	34
5.3.4.7	606Ch Velocity actual value	34
5.3.4.8	6071h Target torque	35
5.3.4.9	6074h Torque demand value	35
5.3.4.10	6077h Torque actual value	35
5.3.4.11	607Ah Target position	35
5.3.4.12	607Ch Home offset	35
5.3.4.13	607Eh Polarity	35
5.3.4.14	6081h Profile velocity in pp-mode	35
5.3.4.15	6083h Profile acceleration	36
5.3.4.16	6084h Profile deceleration	36
5.3.4.17	6087h Torque slope	36

5.3.4.18	6091h Gear ratio	36
5.3.4.19	6098h Homing method	36
5.3.4.20	6099h Homing speeds	36
5.3.4.21	609Ah Homing acceleration	37
5.3.4.22	60FFh Target velocity	37
5.3.4.23	6502h Supported drive modes	37
5.3.5	Manufacturer custom objects	38
5.3.6	Manufacturer custom objects descriptions	38
5.3.6.1	2002h Input status	38
5.3.6.2	2003h Output status	38
5.3.6.3	2004h Homing ok	38
5.3.6.4	2006h Warnings	38
5.3.6.5	2020h Diagnostic	39
5.4	Startup parameters	39
5.4.1	Startup parameters objects	42
5.4.2	Startup parameters objects descriptions	42
5.4.2.1	800001h System endianness	42
5.4.2.2	800002h System start	42
5.4.2.3	800003h System Emergencies Enabled	43
5.4.2.4	800101h Pid Selection	43
5.4.2.5	800201h KP position	43
5.4.2.6	800202h KI position	43
5.4.2.7	800301h KP Speed	43
5.4.2.8	800302h KI Speed	43
5.4.2.9	800401h Profile Check	43
5.4.2.10	800402h Profile Timeout	43
5.4.2.11	8005h Target Scale	43
5.4.2.12	8006h Actuator screw pitch	44
5.4.2.13	8007h Torque Homing Threshold	44
5.4.2.14	8008h Actuator Type	44
5.4.2.15	8009h PDS FSA Enable	44
5.5	Diagnostic behaviour	44
5.5.1	Emergency Object	44
5.5.2	Errcode codes and Error register bits	45
5.5.3	Warnings	46
5.6	Profile position	47
5.7	Profile velocity	49
5.8	Profile Torque	50
5.9	Homing mode	50
5.10	Jog mode	52
5.11	Inputs GPIO	53
5.12	Output GPIO	53

Chapter 6 Uvix	54
6.1 Introduction	54
6.2 General information	55
6.3 Status information	56
6.4 Details	57
6.4.1 Variables	57
6.4.2 Alarms	57
6.4.3 Commands	60
6.5 Configuration	61
6.5.1 Actuator	61
6.5.2 Motion	61
6.5.3 Communication	62
6.5.4 GPIO	62
6.6 Commissioning	63
6.6.1 DRVI states	63
6.6.2 Mode operation parameters	64
6.6.2.1 Homing	64
6.6.2.2 Speed Profile	65
6.6.2.3 Absolute position	65
6.6.2.4 Relative position	66
6.6.2.5 Torque profile	67
6.6.3 PID	67
6.7 EtherCAT configuration	68
6.8 UVIX USB Gateway	69
6.8.1 Main page	69
6.8.2 Firmware update	70

General recommendations

⚠ Please comply with the recommendations for safe use described in this document.

- Some hazards can only be associated with the product after it has been installed on the machine/equipment. It is the responsibility of the end user to identify these hazards and reduce the risks associated with them.
- For information regarding the reliability of the components, contact Camozzi Automation.
- Before commissioning, carefully check that the DRVI has been correctly configured with regard to the data relating to the determination of the position and movement of the device. Failure to follow these instructions can result in injury or equipment damage.
- Avoid unprotected contact with hot surfaces. Be sure that the DRVI can dissipate the heat generated during normal operation to avoid equipment damage.
- Read the information in this document carefully before using the product.
- Keep this document in a safe place and close at hand for the whole of the product's life cycle.
- Pass this document on to any subsequent owner or user.
- The instructions in this manual must be observed in conjunction with the instructions and additional information concerning the product in this manual, available from the following reference links:
 - Website www.camozzi.com
 - Camozzi general catalogue
 - Technical assistance service
- Assembly and commissioning must be performed exclusively by qualified and authorised personnel on the basis of these instructions.
- It is the responsibility of the system/machine designer to ensure the correct selection of the most suitable component according to the intended application.
- Use of appropriate personal protective equipment is recommended to minimise the risk of physical injury.
- For all situations not contemplated in this manual and in situations in which there is the risk of potential damage to property, or injury to persons or animals, contact Camozzi for advice.
- Do not make unauthorised modifications to the product. In this case, any damage or injury to property, persons or animals will be the responsibility of the user.
- It is recommended to comply with all safety regulations that apply to the product.
- Never intervene on the machine/system until you have verified that all working conditions are safe.
- Before installation or maintenance, ensure that the required safety locks are active, and then disconnect the electrical mains (if necessary) and system pressure supply, discharging all residual compressed air from the circuit and deactivating residual energy stored in springs, condensers, recipients and gravity.
- After installation or maintenance, the electrical power supply (if necessary) must be reconnected, and the regular operation of the product must be checked. In the event of a malfunction, the product

1.1 Product storage and transport

must not be used.

- Avoid covering the equipment with paint or other substances that may reduce heat dissipation.

1.1 Product storage and transport

- Adopt all measures possible to avoid accidental damage to the product during transport, and when available use the original packaging.
- Observe the specified storage temperature range of $-20 \div 70$ °C.

1.2 Use

- Make sure that the distribution network voltage and all operating conditions are within the permissible values.
- The product may only be used in observance of the specifications provided; if these requirements are not met, the product may only be used upon authorisation by Camozzi.
- Follow the indications shown on the identification plate.

1.3 Limitations of use

- Do not exceed the technical specifications given in Paragraph 2 (General characteristics and conditions of use) and in the Camozzi general catalogue.
- Do not install the product in environments where the air itself may cause hazards.
- With the exception of specific intended uses, do not use the product in environments where direct contact with corrosive gases, chemicals, salt water, water or steam may occur.

1.4 Maintenance

- Incorrectly performed maintenance operations can compromise the good working order of the product and harm surrounding persons.
- Check conditions to prevent sudden release of parts, then suspend the power supply and allow residual stresses to discharge before taking action.
- Assess the possibility of having the product serviced by a technical service centre.
- Never disassemble a live unit.
- Isolate the product electrically before maintenance.
- Always remove accessories before maintenance.
- Always wear the correct personal protective equipment as envisaged by local authorities and in compliance with current legislation.
- In the event of maintenance, or replacement of worn parts, exclusively use the original Camozzi kits and ensure that operations are performed by specialised and authorised personnel. Otherwise product approval will be rendered invalid.

1.5 Ecological Information

1.5 Ecological Information

- At the end of the product's life cycle, it is recommended to separate the materials for recycling.
- Follow the waste disposal regulations in force in your country.
- The product and relative parts all comply with the ROHS and REACH standards.

Introduction

2.1 About this manual

This manual contains the technical description of the universal integrated servomotor, designed by Camozzi Automation S.p.A.

▲ Failure to observe the information contained in this manual can result in injury or equipment damage.

Please contact Camozzi Automation S.p.A. for technical assistance.

PRODUCT SPECIFICATIONS AND DATA ARE SUBJECT TO CHANGE WITHOUT NOTICE.

© Camozzi Automation S.p.A. All rights reserved.

2.2 Unit overview

The universal integrated servomotor unit is composed of a brushless or stepper motor and a FOC (Field Oriented Control) drive.

The unit is equipped with EtherCAT interface, that provides fieldbus communication capability with other devices, such as PLCs.

An absolute encoder allows to detect the rotor position of the motor, which is a fundamental quantity for the closed-loop control algorithms.

The power supply is divided in two sections: one for the logic stage and one for the power stage. In the following chapter are described the technical data of the drive.

Technical data

3.1 Environmental conditions

⚠ The drive installation must respect the environmental conditions specified in Table 3.1.

Table 3.1: Environmental conditions.

Condition	Value
Protection class	IP65, except motor shaft
Operating ambient temperature	-20 ... 50 °C
Storage ambient temperature	-20 ... 70 °C
Air humidity (non-condensing)	5 ... 95 %
Maximum altitude	1000 m

3.2 Electrical specifications

3.2.1 Power supply

The power supply section of the drive is divided into two parts:

- Logic (VL): provides supply to the logic stage, fieldbus interface and input-outputs.
- Main (VDC): provides supply to the power stage.

It's recommended to supply both Logic and Main power supplies by 2 different PELV (Protective Extra-Low Voltage) electronic circuits compliant to EN 60204-1

In Table 3.2 are shown the power supply operating ranges.

Table 3.2: Power supplies ranges.

Supply	Nominal value	Min/Max values
VL	24 V	24 V \pm 10%
VDC	48 V	60 V

The current absorption of the logic stage is <200mA (including auxiliary +24V output at maximum load).

⚠ During deceleration ramps the motor acts as a generator, returning a voltage on the VDC bus. The entity of such regeneration depends on the deceleration value and on the moment of inertia of the load attached to the shaft. If the voltage generated reaches the maximum VDC voltage, **the excess energy must be dissipated using an external braking system**, or changing the deceleration value otherwise the drive or the power supply could be damaged.

⚠ Install fuses for power supply cable in accordance with the electrical requirements of the equipment (be careful about inrush currents). A recommended fuse value is **T4A**.

It is also recommended to install a capacitor of 1000 uF, rated 100 V, after the output of the power supply.

3.2 Electrical specifications

⚠ The drive does not have an inrush current limitation, hence you must use the input of the power supply to turn the drive on and off. Never switch the output voltage of the power supply (hot plugging). In Figures 3.1 and 3.2 are shown the wiring examples for VDC and VL.

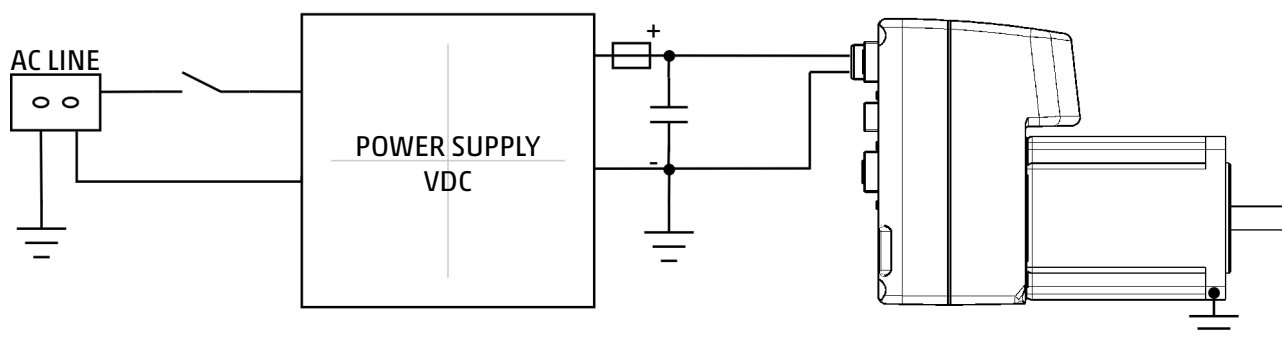

Figure 3.1: VDC wiring example.

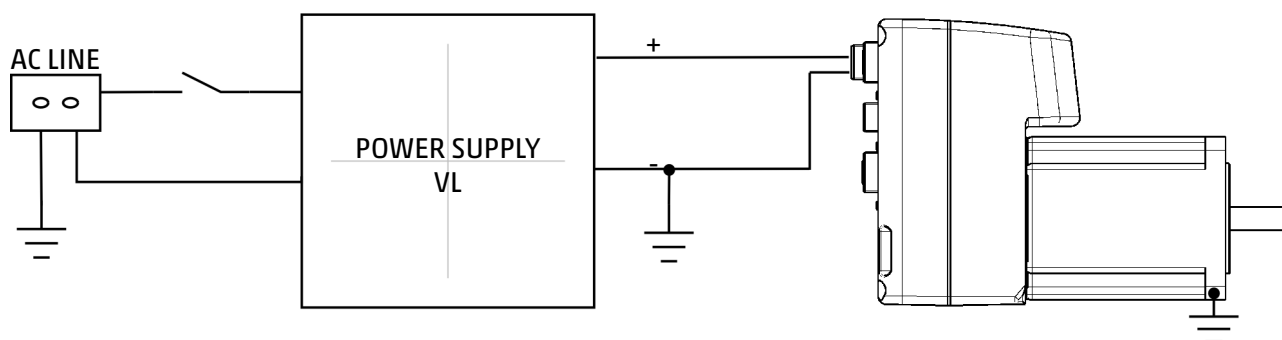

Figure 3.2: VL wiring example.

3.2.2 Wiring

The actual cable type, wire gauge, shield type, and filtering devices used are dependent on the environment, application, and system. However, we advise to use the following guidelines, when sizing the cables:

- The minimum section for the power supply cable should be AWG22 (0.75 mm²) when the motor uses the nominal current.
- For length less than 15 m, DC power supply cables can be used. Otherwise AC power supply cables should be used.
- To reduce EMC issues, use twisted and shielded cables.
- The shield should be connected to ground on the power supply side.

3.2.3 Encoder

The motor shaft position is measured using an absolute magnetic encoder.

3.3 Electrical connections

3.3 Electrical connections

In Figure 3.3 is shown the placement of the electrical connectors.



Figure 3.3: Connectors placement.

In Table 3.3 are shown the functionalities of the electrical connectors.

Table 3.3: Electrical connections.

Connection	Name	Functionality
①	PWS	Power supply
②	I/O	Inputs and outputs
③	STO	Safe Torque Off (when present) ⚠ NOT CERTIFIED
④	P1 = IN	EtherCAT Fieldbus Interface
⑤	P2 = OUT	EtherCAT Fieldbus Interface
⑥	-	USB (Micro-B)

NOTE: All connectors are screw type. During the wiring phase, be careful not to tighten the connectors too forcefully. The use of tools to tighten the connectors is absolutely not recommended.

3.3 Electrical connections

3.3.1 1 - Power supply

The power supply connector is a 5-poles M12 (male) A-coded. In Table 3.4 is represented the pinout of the power supply connector.

Table 3.4: 1 - Power supply connector pinout.

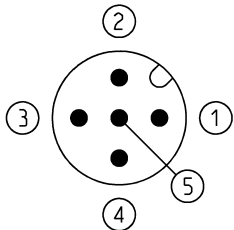
PIN	Signal	Function	Symbol
1, 5	VDC	Main power supply	
2	GND	Main power ground	
3	VL	Logic power supply	
4	GND	Main power ground	

Camozzi connector receptacle:

- CS-LF05HC, straight connector M12 5-poles male.
- CS-LF04HB, straight connector M12 5-poles male (Pin 5 is not connected).
- CS-LF05HB-D200, cable with straight M12 5-poles male connector, length 1m.
- CS-LF05HB-D500, cable with straight M12 5-poles male connector, length 5m.

⚠ The pins with GND indication are internally connected.

3.3.2 2 - GPIO

The GPIO connector is a 12-poles M12 (female) A-coded. In Table 3.5 is described the functionality of each pin and is represented the pinout of the GPIO connector.

3.3 Electrical connections

Table 3.5: 2 - GPIO connector pinout.

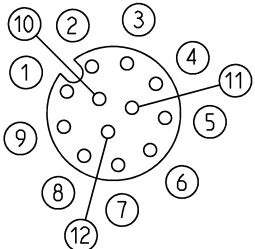
PIN	Signal	Function	Symbol
1, 2	IN1	Digital input 1 (compliant to IEC61131-2)	
3, 4	IN2	Digital input 2 (compliant to IEC61131-2)	
5, 6	OUT	Solid state relay output (PTC resettable fuse, 0.5 A hold current)	
7, 8	EXT PROXY	Digital input (24 V) for external proximity	
9, 10	PROXY HOMING	Digital input (24 V) for homing proximity	
11	GND	Digital ground	
12	+24V	Auxiliary +24 V output, max 130 mA	

NOTE: the EXT PROXY is usually used to connect the optional limit switch sensor, whilst the PROXY HOMING is used for the homing zero position

NOTE: IN1 and IN2 are general purpose inputs, typically they could be used for the jog clockwise and counter-clockwise function (see Chapter 4.2)

3.3 Electrical connections

Camozzi connector receptacle:

- CS-LM12HC, circular connector field attachable M12 12-poles (male) A-coded.
- CS-LO12HC-0025, straight connector M12 12-poles (male) and two M8 female (proximity), length 20 cm.
- CS-LM12HC-D500, straight connector M12 12-poles (male), length 5m.

Digital inputs are bidirectional: in Figure 3.4 is represented the input hardware stage.

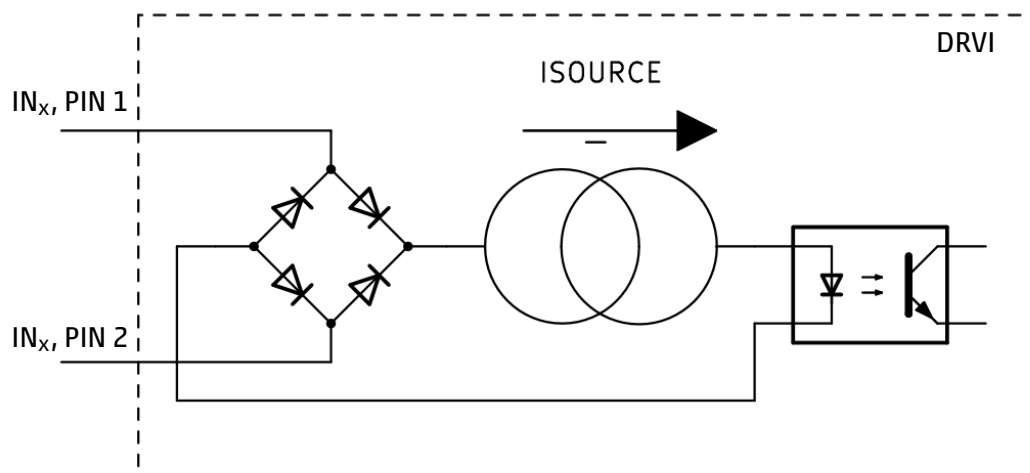

Figure 3.4: GPIO IN stage.

In Figure 3.5 is represented the output hardware stage.

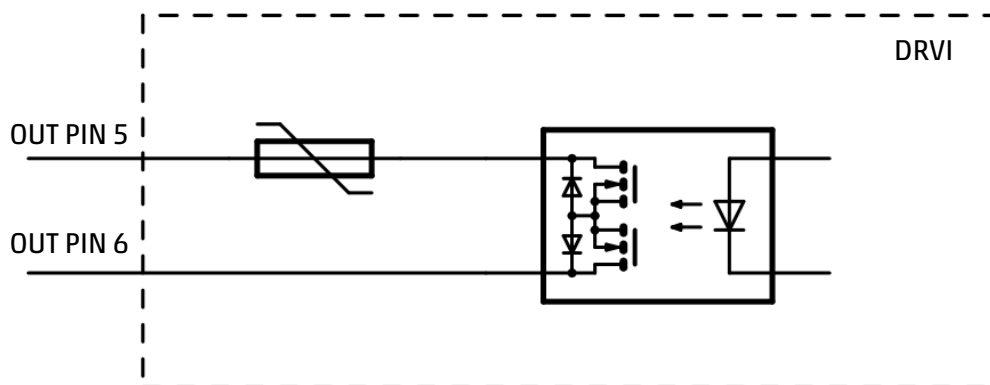

Figure 3.5: GPIO OUT stage.

3.3.3 3 - STO (NOT CERTIFIED)

⚠ STO (SAFE TORQUE OFF) FEATURE IS NOT CERTIFIED.

The STO connector (when present) is 4-poles M8 (female) A-coded. In Table 3.6 is shown the connector pinout and is displayed the STO connector. To allow the motor movement, IN1 and IN2 must be connected to +24 V, while COM1 and COM2 to GND. If IN1 or IN2 voltages are missing, the STO intervenes disconnecting the motor phases.

Camozzi connector receptacle:

- CS-DM04HB, circular connector field attachable M8 4-poles (male) A-coded.

3.3 Electrical connections

- CS-LM04HB-D500, straight connector M8 4-poles (male), length 5m.

Table 3.6: 3 - STO connector pinout.

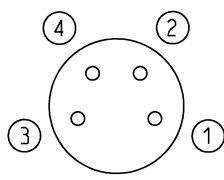
PIN	Signal	Function	Symbol
1	IN1	STO1 signal	
2	COM1	Common signal of STO1	
3	IN2	STO2 signal	
4	COM2	Common signal of STO2	

3.3.4 4, 5 - Ethernet fieldbus interface

The Fieldbus connectors are 4-poles M12 (female) D-coded. In Table 3.7 are shown the connector pinout and the fieldbus connector (PORT 1, PORT 2).

Table 3.7: 4, 5 - Fieldbus connector pinout.

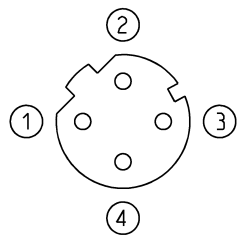
PIN	Signal	Function	Symbol
1	TXP	Transmission data (+)	
2	RXP	Reception data (+)	
3	TXN	Transmission data (-)	
4	RXN	Reception data (-)	

3.4 LED indicators

Camozzi Ethernet fieldbus cables:

- CS-SB04HB-D100, co-molded cable with straight M12D 4-poles male connector, length 1m.
- CS-SB04HB-D500, co-molded cable with straight M12D 4-poles male connector, length 5m.
- CS-SB04HB-DA00, co-molded cable with straight M12D 4-poles male connector, length 10m.
- CS-SB04HB-DD00, co-molded cable with straight M12D 4-poles male connector, length 15m.
- CS-SB04HB-DG00, co-molded cable with straight M12D 4-poles male connector, length 20m.
- CS-SB04HB-DJ00, co-molded cable with straight M12D 4-poles male connector, length 25m.
- CS-SB04HB-DM00, co-molded cable with straight M12D 4-poles male connector, length 30m.
- CS-SB04HB-DS00, co-molded cable with straight M12D 4-poles male connector, length 40m.
- CS-SB04HB-DY00, co-molded cable with straight M12D 4-poles male connector, length 50m.
- CS-SE04HB-F050, molded cable with straight RJ45 male – M12D 4 pin female connector (adapter and panel mount) to connect to the controller.

3.3.5 6 - USB interface

The USB port allows the drive configuration using the UVIX interface. The USB connector is a Micro USB type B.

Camozzi connector receptacle:

- G11W-G12W-2, standard cable with micro-USB connector length 2m.

3.3.6 Earth connection

⚠ It is mandatory to connect the motor flange to earth (\perp). The GND must be connected to the earth, using a common central point, near to the power supply.

3.4 LED indicators

The integrated drive provides visual information using LED indicators. Their functionality is shown in Table 3.8, and their detailed description is given in Table 3.9.

Table 3.8: LED indicators functionality.





















Name	Color	Function	Indicator
L/A1	Green / yellow (bicolor)	Link / activity LED for Ethernet channel 1	
L/A0	Green / yellow (bicolor)	Link / activity LED for Ethernet channel 0	
ERR	Red	Error	
RUN	Green	Run	
SYS	Red / green (bicolor)	Drive system LED	

Table 3.9: LED indicators description.

Name	Color	State	Description
L/A1		OFF	No link has been established on Ethernet Port 0
		ON	Link has been established on Ethernet Port 1
		BLINK	Data is received or transmitted on Ethernet Port 1
L/A0		OFF	No link has been established on Ethernet Port 0
		ON	Link has been established on Ethernet Port 0
		BLINK	Data is received or transmitted on Ethernet Port 0
ERR		OFF	No error, device is in WORK state
		BLINK every 400 ms	Configuration error
		BLINK every 1.2 s	Watchdog error
		BLINK every 1.4 s	Communication error (cable not connected)
RUN		OFF	The device is in INIT state
		BLINK every 400 ms	The device is in PRE-OPERATIONAL state
		BLINK every 1.2 s	The device is in SAFE-OPERATIONAL state
		ON	The device is in OPERATIONAL state
SYS		1 BLINK	Servo OFF
		2 BLINK	Servo ON
		1 BLINK	VL / VDC UVLO or OVLO error
		2 BLINK	Over temperature or I ² T error
		3 BLINK	STO error
		4 BLINK	Homing error / internal error

Operation Modes

This Chapter describes the possible operation modes of the drive that could be fieldbus modes or digital inputs mode

4.1 Fieldbus Modes

4.1.1 Speed

This drive mode operation requires a specific target speed, acceleration and deceleration: once the velocity target is set, the motor accelerates until the target speed is reached and then maintains the required velocity until a new request is made. The speed profile executed is trapezoidal.

In Figure 4.1 is shown an example of speed profile with the following parameters:

- Target acceleration = 60 RPM / s
- Target deceleration = 60 RPM / s
- Initial speed = 0 RPM
- Target speed = 60 RPM (target given at $t = 0$ s)
- Target speed = 0 RPM (target given at $t = 2$ s)

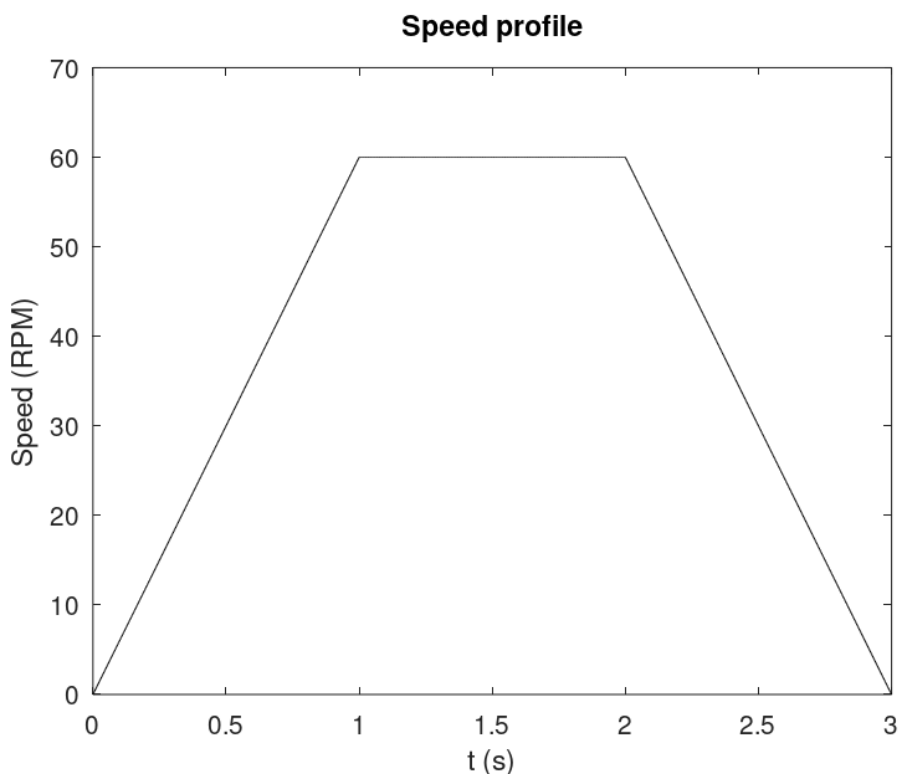

Figure 4.1: Speed profile example.

4.1 Fieldbus Modes

4.1.2 Positioning

This drive operation modes requires a specific target position, velocity, acceleration and deceleration, to compute the motion profile used to reach the target position. The position profile executed is of "S" type and the speed profile is trapezoidal.

In Figure 4.2 is shown an example of positioning profile with the following parameters:

- Initial position = 0 °
- Target position = 720 ° (target given at t = 0 s)
- Initial speed = 0 RPM
- Target speed = 60 RPM
- Target acceleration = 60 RPM / s
- Target deceleration = 60 RPM / s

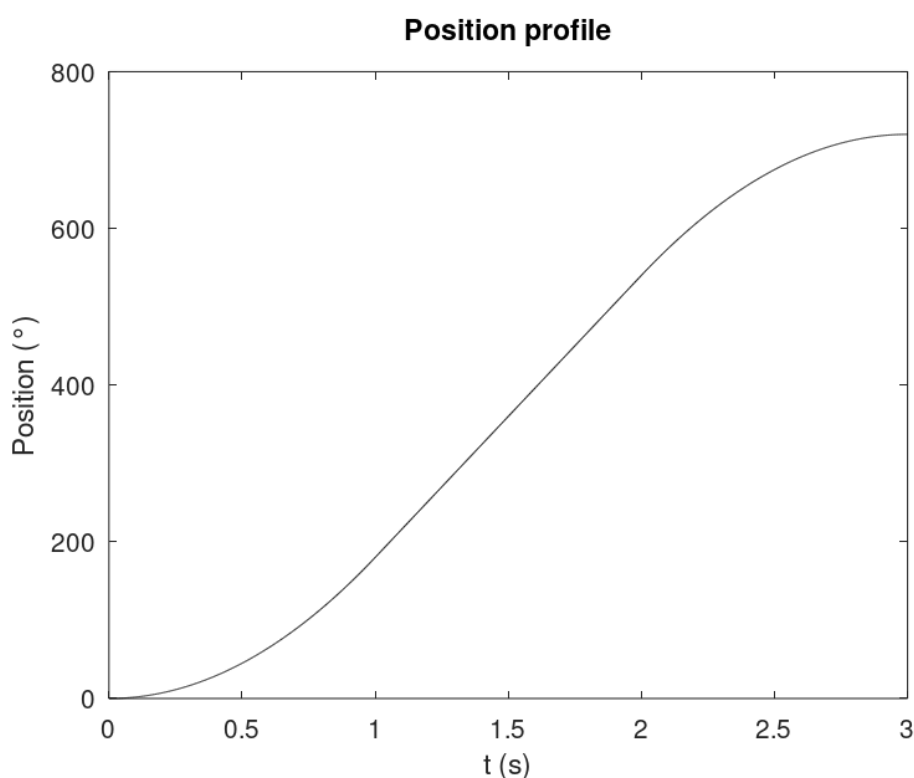

Figure 4.2: Positioning profile example.

In Figure 4.3 are represented both the position (continuous line) and speed (dashed line) profiles per unit (position / 360 ° and speed / 60 RPM).

4.1 Fieldbus Modes

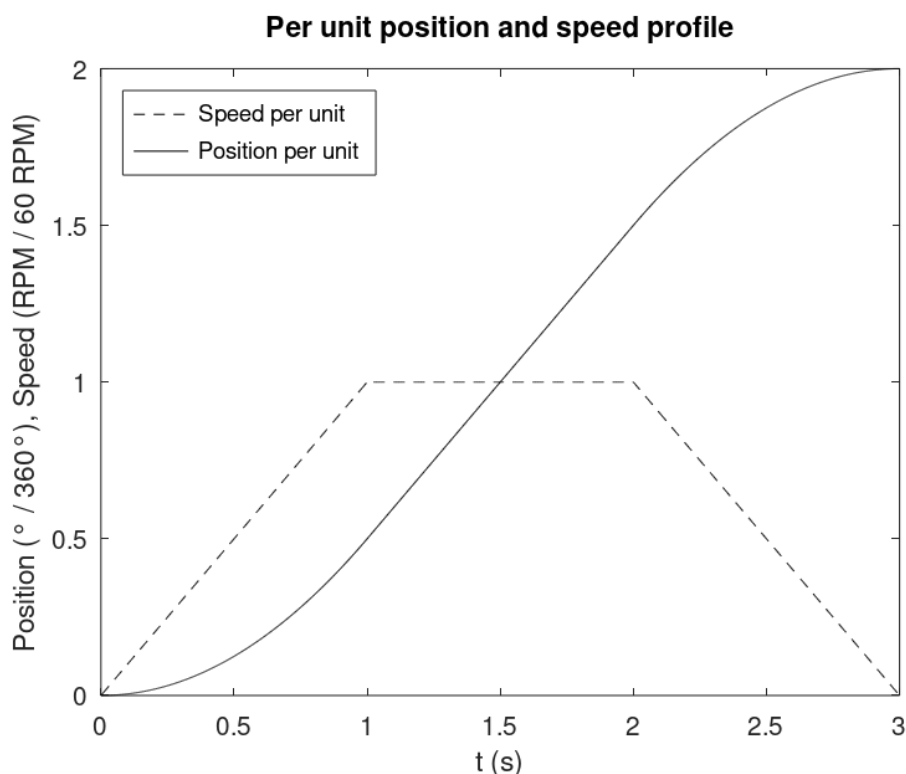

Figure 4.3: Positioning and speed profile example.

4.1.2.1 Relative Positioning

In relative positioning profile the target is computed as offset with respect to the current position. For example, if the actual absolute rotor position is 360° and the requested relative positioning target is 360° , the motor will rotate to reach the absolute position of 720° .

4.1.2.2 Absolute Positioning

In absolute positioning profile the target is absolute. For example, if the absolute rotor position is 360° and an absolute positioning target of 360° is given, the motor will not move.

4.1.3 Torque

This drive operation mode requires a specific target (current) torque, positive torque slope and negative torque slope. Target torque is expressed in mA and torque slopes in mA / s.

In Figure 4.4 is shown an example of torque profile with the following parameters:

- Positive torque slope = 1000 mA / s
- Negative torque slope = 1000 mA / s
- Initial torque = 0 mA
- Target torque = 1000 mA (target given at $t = 0$ s)
- Target torque = 0 mA (target given at $t = 2$ s)

4.1 Fieldbus Modes

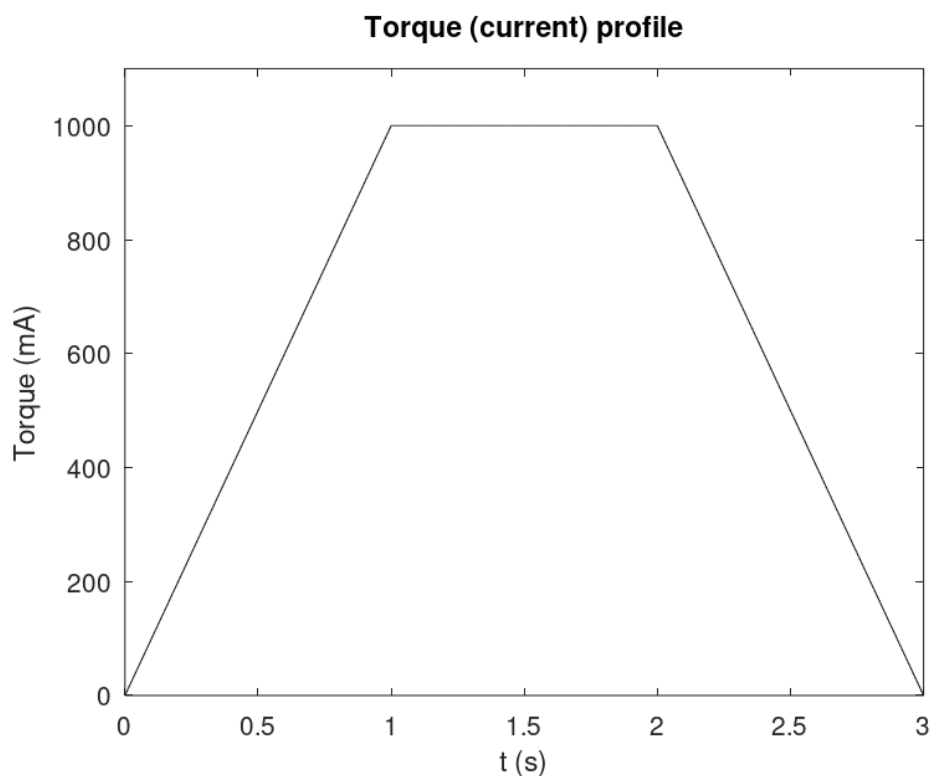

Figure 4.4: Torque (current) profile example.

4.1.4 Jog

The JOG mode allows to control the drive in speed mode using two bits of the controlword

Table 4.1: JOG truth table.

Bit 6	Bit 5	Effect
0	0	Stop (zero speed)
1	0	Clockwise rotation
0	1	Counter-clockwise rotation
1	1	Invalid command (previous state persists)

4.1 Fieldbus Modes

4.1.5 Homing

In this Section are described the possible homing procedures. It is mandatory to execute homing before using positioning operations. Homing parameters can be configured using UVIX interface (refer to Section 6.6.2.1). If proximity is used it must be connected to the PROXY INPUT (refer to Section 3.3.2).

4.1.5.1 Positioning homing

Homing at the current position (refer to Figure 4.5). This mode does not require an external proximity

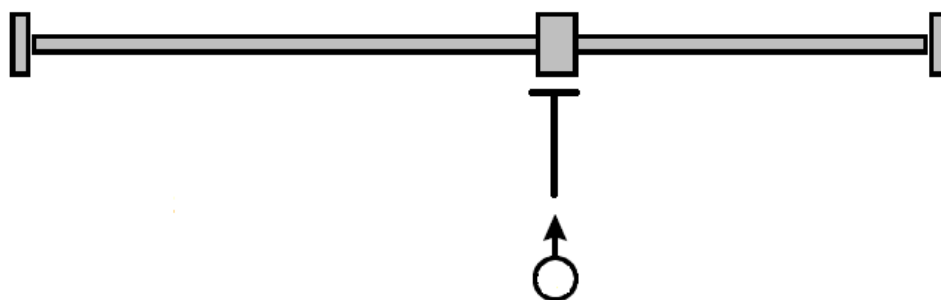

Figure 4.5: Positioning homing.

and the homing procedure consists of setting the current position (without moving the motor) as zero position.

4.1.5.2 Proximity homing: negative direction

Proximity search in negative direction (refer to Figure 4.6).

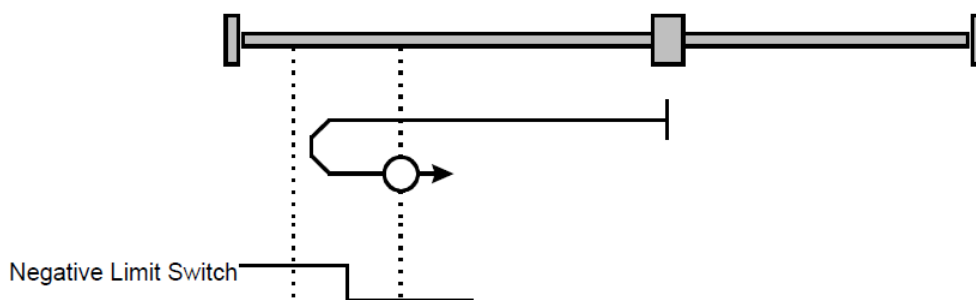

Figure 4.6: Proximity homing: negative direction.

In this mode, the motor searches for the zero proximity in the negative direction of the movement, with the velocity set to "homing speed search". As soon as the proximity is detected, the motor stops and exits the proximity, in the opposite direction, with the velocity set to "homing speed out". If the proximity is already detected on the start of the homing procedure, the motion will start with the "homing speed out" phase. If the proximity is surpassed because of the inadequate speed / deceleration combination, the homing procedure is interrupted and a homing error is returned.

4.1.5.3 Proximity homing: positive direction

Proximity search in positive direction (refer to Figure 4.7).

4.1 Fieldbus Modes

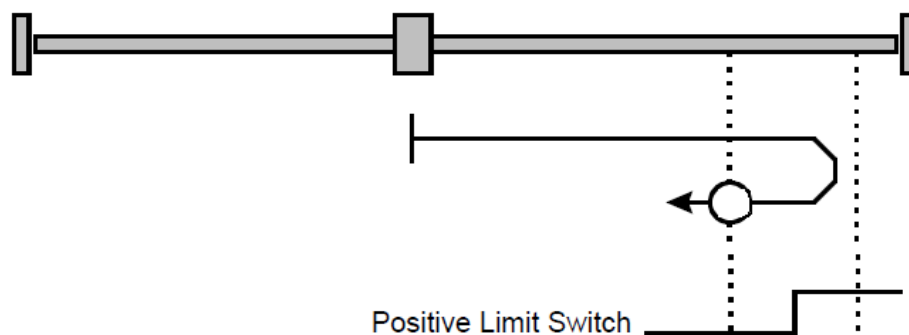

Figure 4.7: Proximity homing: positive direction.

In this mode, the motor searches for the zero proximity in the positive direction of the movement, with the velocity set to "homing speed search". As soon as the proximity is detected, the motor stops and exits the proximity, in the opposite direction, with the velocity set to "homing speed out". If the proximity is already detected on the start of the homing procedure, the motion will start with the "homing speed out" phase. If the proximity is surpassed because of the inadequate speed / deceleration combination, the homing procedure is interrupted and a homing error is returned.

4.1.5.4 Proximity homing: negative direction + zero encoder

Proximity search in negative direction and then search for the index pulse (zero of the encoder) in the positive direction (refer to Figure 4.8).

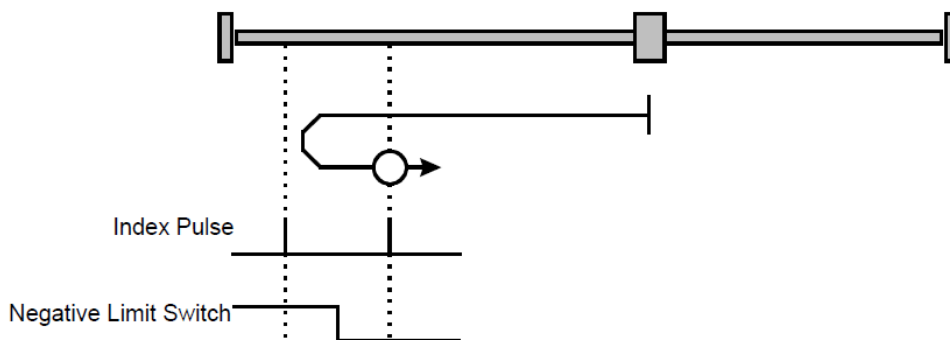

Figure 4.8: Proximity homing: negative direction + zero encoder.

In this mode, the motor searches for the zero proximity in the negative direction of the movement, with the velocity set to "homing speed search". As soon as the proximity is detected, the motor stops and exits the proximity, in the opposite direction, with the velocity set to "homing speed out", until it finds the zero encoder. If the proximity is already detected on the start of the homing procedure, the motion will start with the "homing speed out" phase. If the proximity is surpassed because of the inadequate speed / deceleration combination, the homing procedure is interrupted and a homing error is returned.

4.1 Fieldbus Modes

4.1.5.5 Proximity homing: positive direction + zero encoder

Proximity search in positive direction and then search for the index pulse (zero of the encoder) in the negative direction (refer to Figure 4.9).

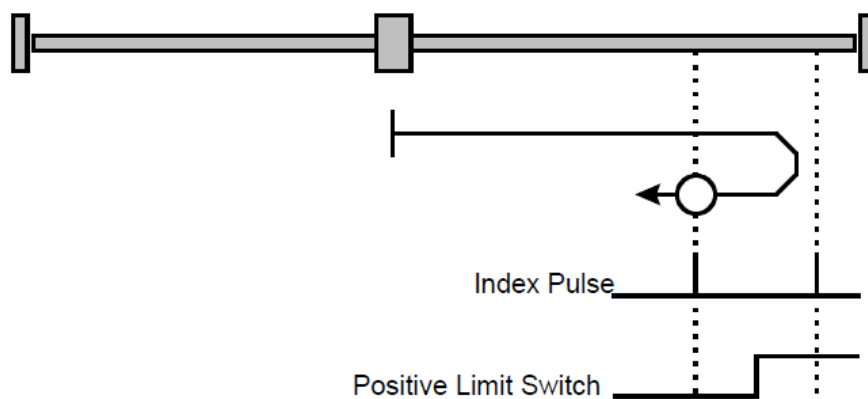

Figure 4.9: Proximity homing: positive direction + zero encoder.

In this mode, the motor searches for the zero proximity in the positive direction of the movement, with the velocity set to "homing speed search". As soon as the proximity is detected, the motor stops and exits the proximity, in the opposite direction, with the velocity set to "homing speed out", until it finds the zero encoder. If the proximity is already detected on the start of the homing procedure, the motion will start with the "homing speed out" phase. If the proximity is surpassed because of the inadequate speed / deceleration combination, the homing procedure is interrupted and a homing error is returned.

4.1.5.6 Torque homing: negative direction

Homing torque in negative direction (refer to Figure 4.10). In this mode the motor rotates in the neg-

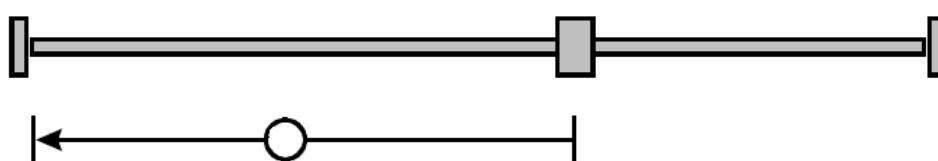

Figure 4.10: Torque homing: negative direction.

ative direction of the movement, with the velocity set to "homing speed search", until it stops against the end of the line and the I^2T reaches the homing set value.

4.1.5.7 Torque homing: positive direction

Homing torque in positive direction (refer to Figure 4.11). In this mode the motor rotates in the positive direction of the movement, with the velocity set to "homing speed search", until it stops against the end of the line and the I^2T reaches the homing set value.

4.1 Fieldbus Modes

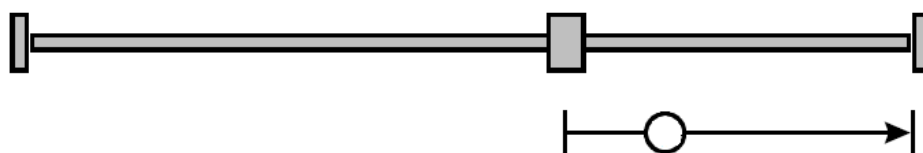

Figure 4.11: Torque homing: positive direction.

4.1.5.8 Torque homing: negative direction + zero encoder

Homing torque in negative direction and then search for the index pulse (zero of the encoder) in the positive direction (refer to Figure 4.12).

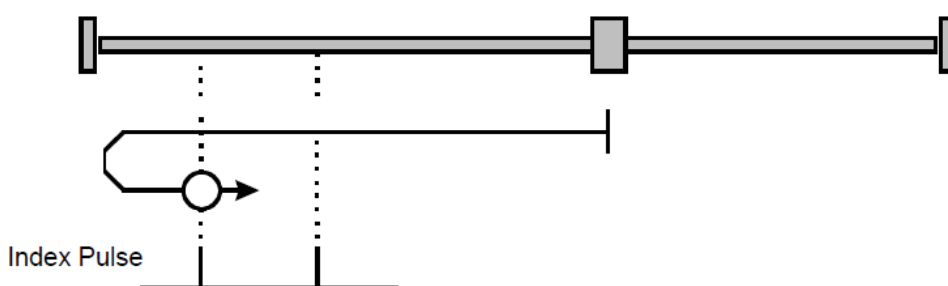

Figure 4.12: Torque homing: negative direction + zero encoder.

In this mode the motor rotates in the negative direction of the movement, with the velocity set to "homing speed search", until it stops against the end of the line and the I^2T reaches the homing set value. At this point the motor rotates in the opposite direction, with the velocity set to "homing speed out", until it finds the zero encoder.

4.1.5.9 Torque homing: positive direction + zero encoder

Homing torque in positive direction and then search for the index pulse (zero of the encoder) in the negative direction (refer to Figure 4.13).

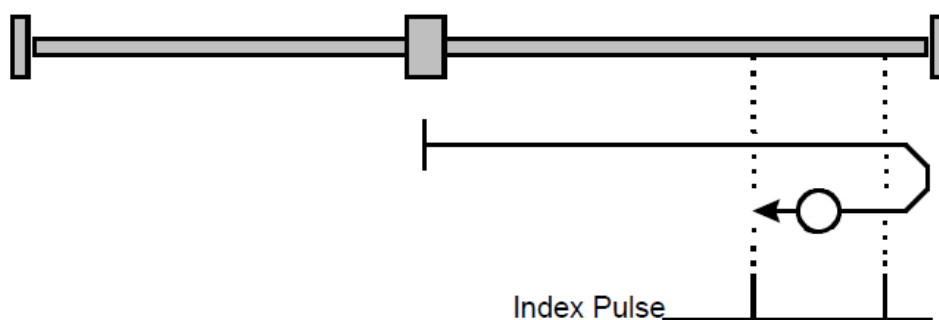

Figure 4.13: Torque homing: positive direction + zero encoder.

In this mode the motor rotates in the positive direction of the movement, with the velocity set to "homing speed search", until it stops against the end of the line and the I^2T reaches the homing set value. At this point the motor rotates in the opposite direction, with the velocity set to "homing speed out", until it finds the zero encoder.

4.1 Fieldbus Modes

4.1.5.10 Homing offset

The Homing offset indicates the configured difference between the **zero position** for the application and the machine **home position** (found during homing). During homing the motor moves to search the home position: it is possible to change the zero position, that by default is set at the same value of the home position, by adding an offset to the home position. This value could be positive or negative and all subsequent absolute movements shall be taken relative to this new zero position. This offset can be set by using the object 607Ch (Home offset parameter see [5.3.4.12](#))

4.2 Digital Inputs mode

4.1.6 Other features

In this chapter are described other features that can be used in combination with the various modes of operation.

4.1.6.1 Profile software limits

Profile software limits can be set to restrict the motion parameters (positions, speed, acceleration and deceleration) to a desired value.

Such limits can be configured using the UVIX interface (refer to Section 6.5.1) and are valid for all the configurations different from "only motor" and for all the modes of operation.

Software limits take effect only after homing execution and if the corresponding "software limits enable" in the protocol is set (refer to Chapter 5 controlword bit11). In case a position software limit error is triggered (for example the servo has been set momentary OFF and the motor has been moved beyond the software position limit or the EXT PROXY INPUT signal has been caught), the drive, if it was moving, stops itself using the QUICK_STOP that is the deceleration parameter set in UVIX (refer to Section 6.5.2) and it goes into error state and the correspondent error is raised on the fieldbus. In such situation, to bring back the motor into the allowed position range, the error must be reset first. Then, it is allowed to move the motor using any of the mode of operations (even if it is still out of the allowed range, because the software limit check will be momentary disabled). The error check on positioning will be restored automatically after the first movement completion (target position for positioning control or zero speed for speed control), provided that the "software limit enable" is still set.

Regarding target position, target speed, acceleration and deceleration values, if their target values exceed the limit value, the set is inhibited, that is, the parameter is not applied (the previous valid parameter remains valid) and the "command refused" warning is raised.

Profile position hardware limit: The position limit feature of Section 4.1.6.1 can be achieved also using a proximity sensor connected to the EXT PROXY INPUT (refer to Section 3.3.2). As soon as the EXT PROXY INPUT goes to HIGH state, the drive behaves as described in Section 4.1.6.1. Note that the hardware limit takes effect only if the "software limits enable" in the protocol is set.

4.1.6.2 Torque limit

Torque limitation is a feature that allows to limit the torque (current) supplied by the motor. This feature can be enabled and disabled using the provided "torque limit enable" in the protocol (refer to Chapter 5, controlword bit12).) and it takes effect for all the modes of operation. The current limit value is configured using the fieldbus interface and it can be changed in real-time using the Target torque parameter (refer to Chapter 5).

4.2 Digital Inputs mode

The drive can be configured to be moved only using digital inputs signals. This functionality excludes the fieldbus and the motor can be moved in speed mode using only inputs IN1 and IN2 to decide the direction of the movement. PROXY EXT and PROXY INPUT can be used as limits of the range of movement

4.2 Digital Inputs mode

(refer to Section 3.3.2). The UVIX application must be used to set and enable the Digital Inputs mode and to set and store in nonvolatile memory the specific parameters of this mode. After these operations, the drive must be rebooted (turn OFF and ON the VL logic power supply) to apply the configuration. In Table 4.2 is shown the truth table of the Digital Inputs mode. Note that the option "rotation direction", settable via UVIX, is ignored when the drive is in Digital Inputs mode.

Table 4.2: Digital Inputs truth table.

IN1	IN2	Effect
LOW	LOW	Stop (zero speed)
HIGH	LOW	Clockwise rotation
LOW	HIGH	Counter-clockwise rotation
HIGH	HIGH	Invalid command (previous state persists)

When the user changes the IN1 or IN2 logical status to value one, the drive begins to move until:

- it reaches one of the PROXIES and in this case it automatically stops itself or
- the user set IN1 and IN2 to the zero logical value.
- the drive has some problems and it stops in error: in this case the only way to know which type of error, it is to check the number of flashes of the error LED; if the drive goes in error, automatically servo will be OFF.

EtherCAT Protocol

This Chapter describes how to configure and control the drive with an EtherCAT PLC. The device supports the CANopen over EtherCAT protocol (CoE), that follows the CiA 301 standard. DS-402 is the device profile for drives and motion control. CoE carries this well-proven profile from CANopen to the EtherCAT environment.

5.1 Conventions

In this Section is given a description about the conventions used in this manual.

The data types used are shown in Table 5.1:

Table 5.1: Data types.

Name	Size
S32	32 bit signed
U32	32 bit unsigned
S16	16 bit signed
U16	16 bit unsigned
S8	8 bit signed
U8	8 bit unsigned
STR	string

In Table 5.2 are shown the units of measurement used by the drive.

Table 5.2: Units of measurement.

Quantity	Unit
Position	Degrees · 100 (*)
	mm · 100 (**)
Speed	RPM · 100 (*)
	mm / s · 100 (**)
Acceleration	RPM / s (*)
	mm / s ² (**)
	mA / s (***)
Deceleration	RPM / s (*)
	mm / s ² (**)
	mA / s (***)
Torque (current)	mA

(*) Used when the drive is configured as "only motor".

(**) Used in all other configurations different from "only motor".

(***) Used in torque (current) control.

5.1 Conventions

A positive position or a positive speed target cause the motor shaft to rotate in a clockwise direction, when the motor shaft is viewed from the front. Example: a position target of 36000, when the drive is configured as "only motor", corresponds to one turn of the shaft in a clockwise direction.

5.1.1 EtherCAT states machine

In Figure 5.1 is shown the EtherCAT states machine, while in Table 5.3 are represented the transitions and the commands involved.

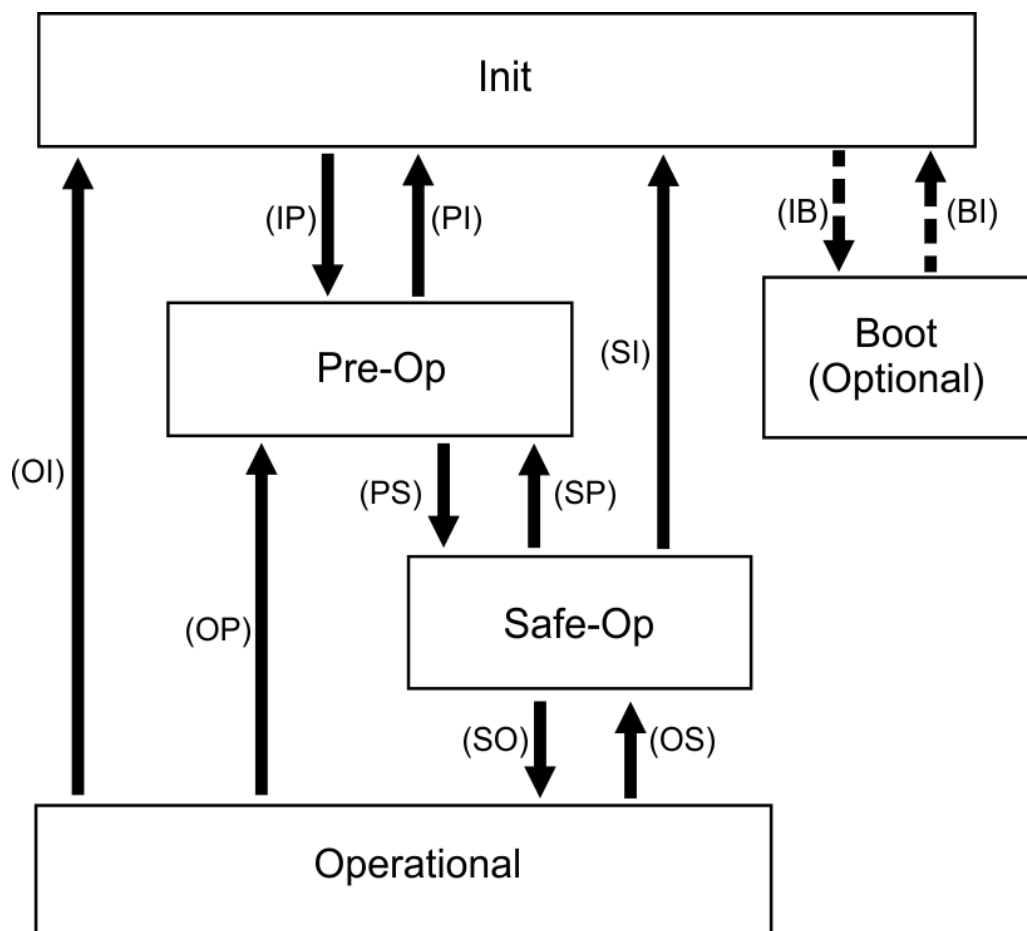

Figure 5.1: EtherCAT states machine.

Table 5.3: Transitions of the state machine.

Transition	Services
(IP)	SDO communication starts: automatically enter in this state after Power On
(PI)	SDO communication is stopped
(PS)	Start PDO communication
(SP)	Stop PDO communication
(SO)	SDO and PDO communications are enabled
(OS)	Reset node command
(OP)	Stop PDO communication
(SI)	Stop PDO and SDO communications
(OI)	Stop PDO and SDO communications

5.2 Configuration via ESI file

The EtherCAT states have different features enabled: they are described in Table 5.4.

Table 5.4: EtherCAT state features.

State	PDO	SDO	Description
Init	NO	NO	Enter in this state automatically after reset / power on
PreOperational	NO	YES	Configure the Sync Manager register for SDO
Safe Op	YES	YES	Configure the Sync Manager register for PDO and PDO mapping
Operational	YES	YES	Every type of messages is possible

5.2 Configuration via ESI file

To configure the DRVI in an EtherCAT network, the ESI (EtherCAT Slave Information) file must be imported into the programming software used for the controller. The ESI is an XML file that is used by EtherCAT master stacks, to configure the slaves and generate network description files. It also describes how data is shared with the slave, including the sync managers used and which PDOs are in each sync manager.

5.3 Object dictionary

Inside the ESI file is present the dictionary with all the objects necessary for the communications and for the management of the drive. Its structure follows the CANopen CiA 301 and CiA 402 standards. In the following Sections is given a description of the dictionary.

5.3.1 Communication Profile - CiA 301 objects

In Table 5.5 are listed the CiA 301 objects.

Table 5.5: CiA 301 objects.

ID	Sub	Description	Type	Access	PDO Mapping	Default Value
1000h	0	Device Type	U32	RO		0xFF7A0192
1001h	0	Error Register	U8	RO	Yes	
1008h	0	Manufacturer Device Name	STR	CONST		DRVI
1018h		Identity object				
	0	number of entries	U8	RO		4
	1	Vendor Id	U32	RO		0x00000097
	2	Product Code	U32	RO		0x0000005A
	3	Revision number	U32	RO		0x00000001
1600h	4	Serial number	U32	RO		0
		Receive PDO Mapping Parameter1				
	0	Number of mapped objects	U8	RW		0x01
	1	Mapping Entry 1	U32	RW		0x60400010
	2	Mapping Entry 2	U32	RW		0
	3	Mapping Entry 3	U32	RW		0

Continued on next page.

5.3 Object dictionary

Table 5.5 – Continued from previous page.

ID	Sub	Description	Type	Access	PDO Mapping	Default Value
	4	Mapping Entry 4	U32	RW		0
	5	Mapping Entry 5	U32	RW		0
	6	Mapping Entry 6	U32	RW		0
	7	Mapping Entry 7	U32	RW		0
	8	Mapping Entry 8	U32	RW		0
1601h	0	Receive PDO Mapping Parameter2				
1602h	0	Receive PDO Mapping Parameter3				
1603h	0	Receive PDO Mapping Parameter4				
1604h	0	Receive PDO Mapping Parameter5				
1605h	0	Receive PDO Mapping Parameter6				
1606h	0	Receive PDO Mapping Parameter7				
1607h	0	Receive PDO Mapping Parameter8				
1A00h		Transmit PDO Mapping Parameter 1				
	0	Number of mapped objects	U8	RW		0x01
	1	Mapping Entry 1	U32	RW		0x60410010
	2	Mapping Entry 2	U32	RW		0
	3	Mapping Entry 3	U32	RW		0
	4	Mapping Entry 4	U32	RW		0
	5	Mapping Entry 5	U32	RW		0
	6	Mapping Entry 6	U32	RW		0
	7	Mapping Entry 7	U32	RW		0
	8	Mapping Entry 8	U32	RW		0
1A01h	0	Transmit PDO Mapping Parameter 2				
1A02h	0	Transmit PDO Mapping Parameter 3				
1A03h	0	Transmit PDO Mapping Parameter 4				
1A04h	0	Transmit PDO Mapping Parameter 5				

Continued on next page.

5.3 Object dictionary

Table 5.5 – Continued from previous page.

ID	Sub	Description	Type	Access	PDO Mapping	Default Value
1A05h	0	Transmit PDO Mapping Parameter 6				
1A06h	0	Transmit PDO Mapping Parameter 7				
1A07h	0	Transmit PDO Mapping Parameter 8				

5.3.2 CiA 301 objects descriptions

In the following Sections are described the CiA 301 objects.

5.3.2.1 1000h Device type

This object contains information on the device type and its functions. It consists in a two 16-bit fields, one describing the profile used and a second containing additional specific information.

5.3.2.2 1001h Error register

This object contains the device's internal error mapping: it is a mandatory object for all devices and it is part of the emergency objects. The values are defined in Table 5.6.

Table 5.6: Error values.

Bit	Optional	Description
0	Mandatory	Generic error
1	Optional	Current
2	Optional	Voltage
3	Optional	Temperature
4	Optional	Communication error
5	Optional	Profile specific
6	Optional	Reserved
7	Optional	Reserved

5.3.2.3 1008h Manufacturer hardware name

This object contains the device name given by the manufacturer .

5.3.2.4 100Ah Manufacturer software version

This object contains the firmware version of the device.

5.3.2.5 1018h Identity object

This object contains information about the device as shown in Table 5.7.

5.3 Object dictionary

Table 5.7: Identity object.

Sub index	Value	Description
0	4	EMCY present / valid
1	97h	Vendor ID
2	5Ah	Product code
3	1	Revision number
4	0	Serial number

5.3.2.6 1600h – 1607h Receive PDO Mapping Parameter

These objects contain the PDO mapping that the device is able to receive.

5.3.2.7 1A00h – 1A07h Transmit PDO mapping parameter

These objects contain the PDO mapping that the device is able to transmit.

5.3 Object dictionary

5.3.3 Device Profile - CiA 402 objects

In Table 5.8 are listed the CiA 402 objects.

Table 5.8: CiA 402 objects.

ID	Sub	Description	Type	Access	PDO Mapping	Default Value
6040h	0	Controlword	U16	RW	RPDO	0
6041h	0	Statusword	U16	RO	TPDO	0
6060h	0	Mode of operation	S8	RW	RPDO	0
6061h	0	Mode of operation display	S8	RO	TPDO	0
6064h	0	Position Actual Value	S32	RO	TPDO	0
606Ch	0	Velocity Actual Value	S32	RO	TPDO	0
6071h	0	Target torque	S16	RW	RPDO	0
6074h	0	Torque demand value	S16	RO		0
6077h	0	Torque actual value	S16	RO		0
607Ah	0	Target position	S32	RW	RPDO	0
607Ch	0	Home offset	S32	RW	RPDO	0
607Eh	0	Polarity	U8	RW	RPDO	0
6081h	0	Profile Velocity in pp-mode	U32	RW	RPDO	0
6083h	0	Profile Acceleration	U32	RW	RPDO	0
6084h	0	Profile Deceleration	U32	RW	RPDO	0
6087h	0	Torque slope	U32	RW		0
6091h		Gear Ratio				
	0	Highest sub-index supported	U8	RO		
	1	MotorRevs	U32	RW		0
	2	ShaftRevs	U32	RW		0
6098h	0	Homing Method	S8	RW	RPDO	37
6099h		Homing Speeds				
	0	Highest sub-index supported	U8	RO		
	1	Fast Homing Speed	U32	RW	RPDO	0
	2	Slow Homing Speed	U32	RW	RPDO	0
609Ah	0	Homing acceleration	U32	RW		0
60FFh	0	Target Velocity	S32	RW	RPDO	0
6502h	0	Supported drive modes	U32	RO		0x8003003F

5.3.4 CiA 402 objects descriptions

In the following Sections are described the CiA 402 objects.

5.3.4.1 603Fh Error code

This object contains the last error code that occurred on the drive.

5.3 Object dictionary

5.3.4.2 6040h Controlword

This object checks the drive status and function. It is used to enable / disable the drive and to start / stop a movement. This object, together with the "status word" is used for the state machine management of the CiA402 profile (refer to the relative manual CiA402-2 and to Figure 5.2). This features can be disabled using the startup parameter 8009h (see 5.4.2.15)

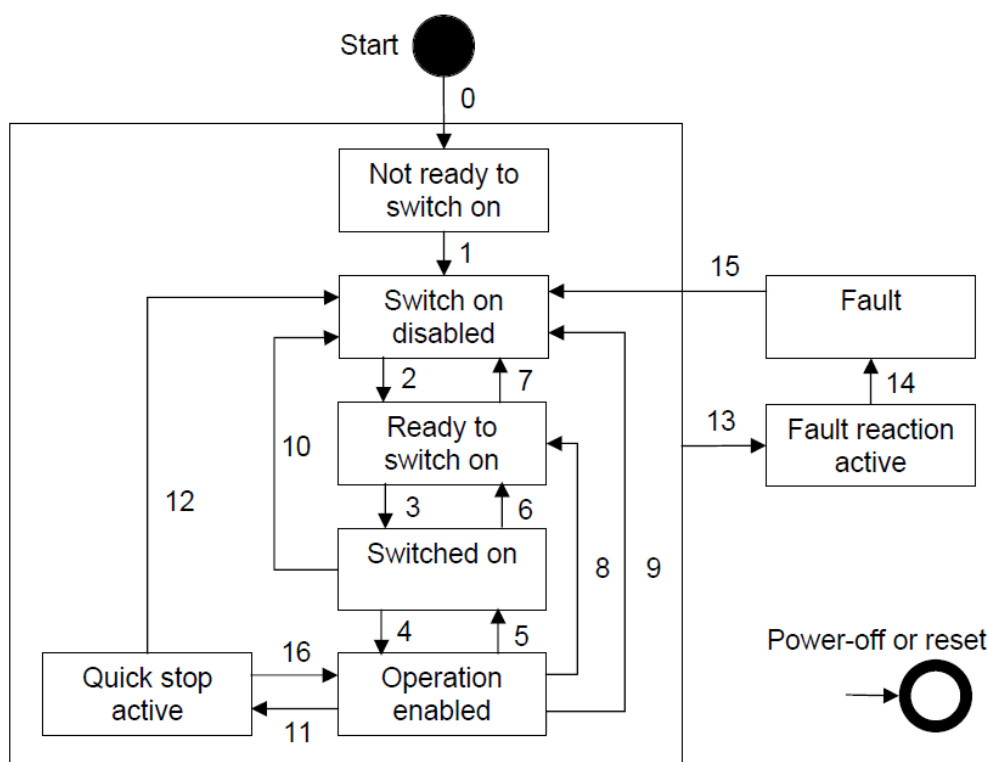

Figure 5.2: Power drive system finite state automaton.

The control word (see Figure 5.3) is subdivided into bits with the following meanings:

- ms = manufacturer specifications
- r = reserved
- oms = dependent on operating mode
- h = halt
- fr = error reset
- eo = enable command
- qs = quick stop
- ev = enable power
- so = startup

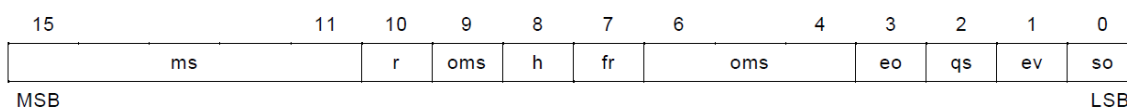

Figure 5.3: Controlword bits.

The possible commands to change the drive status are summarized in Table 5.9.

5.3 Object dictionary

Table 5.9: Controlword bits commands.

Controlword (bit15 ... bit0)	Commands	FSA
xxxx xxxx 0xxx x110	Shutdown	2, 6, 8
xxxx xxxx 0xxx 0111	Switch on	3
xxxx xxxx 0xxx x111	Enable operation	4, 16
xxxx xxxx 0xxx xx0x	Disable voltage	7, 9, 10, 12
xxxx xxxx 0xxx x01x	Quick stop	7, 10, 11
xxxx xxxx 0xxx 0111	Disable operation	5
xxxx xxxx 1xxx xxxx	Fault reset	
xxxx 1xxx xxxx xxxx	Sw Limits enable	
xxx1 xxxx xxxx xxxx	Torque limit enable	

The bit 8 is the halt function and it interrupts the command execution, to continue the movement it must be reset, and a new start must be triggered (depending on the operating mode).

5.3.4.3 6041h Statusword

The status word (see Figure 5.4) is a read-only object that represents the current status of the drive. It is subdivided into bits with the following meanings:

- ms = manufacturer specifications (bit 8 = busy, bit 15 = homing ok)
- oms = dependent on operating mode
- ila = internal limits active
- tr = target reached
- rm = remote
- w = warning (drive status does not change)
- sod = operation disabled
- qs = quick stop
- ve = voltage enabled
- f = error (drive in error status)
- oe = command enabled
- so = active operation
- rtso = ready for operation

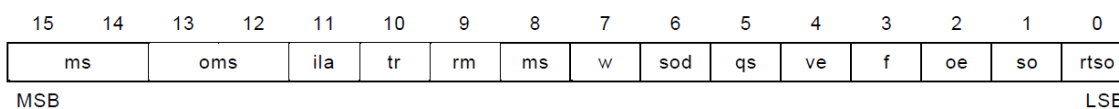

Figure 5.4: Statusword bits

The bit configurations according to drive status is summarized in Table 5.10.

5.3 Object dictionary

Table 5.10: Statusword bits.

Statusword (bit15 ... bit0)	Drive status
xxxx xxxx x0xx 0000	Not ready to operate
xxxx xxxx x1xx 0000	Operation disabled
xxxx xxxx x01x 0001	Ready for operation
xxxx xxxx x01x 0011	Operation active
xxxx xxxx x01x 0111	Command active
xxxx xxxx x00x 0111	Quick stop active
xxxx xxxx x0xx 1111	Error during command
xxxx xxxx x0xx 1000	Drive in error status
xxxx xxxx 1xxx xxxx	Warning
xxxx x1xx xxxx xxxx	Target reached
xxx1 xxxx xxxx xxxx	Jog left
xx1x xxxx xxxx xxxx	Jog righth or Torque Limit enabled
x1xx xxxx xxxx xxxx	Manual mode
1xxx xxxx xxxx xxxx	Sw limits enabled

5.3.4.4 6060h Mode of operation

This object contains the drive operating mode request. The operating modes are specified in Table 5.11.

Table 5.11: Mode of operation bits.

Value	Operating mode
0	No mode requested
1	Position profile
3	Velocity profile
4	Torque profile
6	Homing mode
14	Jog mode

5.3.4.5 6061h Mode of operation display

This object contains the operating mode value in which the drive is located. It can be one of the profiles listed in Table 5.11.

5.3.4.6 6064h Position actual value

This object contains the current position value measured by the drive, expressed in the set unit of measurement.

5.3.4.7 606Ch Velocity actual value

This object contains the actual velocity value measured by the drive, expressed in the set unit of measurement.

5.3 Object dictionary

5.3.4.8 6071h Target torque

This object shall indicate the configured input value for the torque controller in profile torque mode, in position mode and velocity mode.

5.3.4.9 6074h Torque demand value

This object shall provide the output value of the trajectory generator.

5.3.4.10 6077h Torque actual value

This object shall provide the actual value of the torque. It shall correspond to the instantaneous torque (current) in the motor.

5.3.4.11 607Ah Target position

This object contains the position that the motor must reach when the operation is in the position profile, using the velocity and acceleration parameters specified by the designated objects. The target position can be considered as an absolute or relative value according to the bit "abs / rel" of the controlword (specific bits for the profile). Upon reaching the position, bit 10 "target reached" of the statusword is set.

5.3.4.12 607Ch Home offset

This object contains the offset to apply to the physical zero position (imposed by the proximity position) to obtain the zero position of the motor. The drive execute the homing procedure requested (stop on switch, stop on zero encoder, stop on current threasold, etc.) and when it is finished, it sets the actual position to the offset value.

5.3.4.13 607Eh Polarity

This object allows the motor rotation direction to be reversed, in order to change the movement direction based on the physical mounting of the motor. Setting bit 7 reverses the rotation direction.

NOTE: this parameter has an impact to ALL the mode of operation (homings, positioning, speed, torque)

Table 5.12: Polarity values.

Value	Direction
0x00	Forward
0x80	Reverse

5.3.4.14 6081h Profile velocity in pp-mode

This object contains the value of the velocity reached after the acceleration phase, during the position profile movement, valid for both directions.

5.3 Object dictionary

5.3.4.15 6083h Profile acceleration

This object contains the acceleration value used during the position profile movement, which determines the ramp with which the velocity set in the previous object will be reached.

5.3.4.16 6084h Profile deceleration

This object contains the deceleration value used during the position profile movement, which determines the ramp with which the zero velocity will be reached.

5.3.4.17 6087h Torque slope

This object shall indicate the configured rate of change of torque. The value shall be given in units of per thousand of rated torque per second.

5.3.4.18 6091h Gear ratio

This object shall indicate the configured number of motor shaft revolutions and the number of driving shaft revolutions. The gear ratio shall be calculated by the following formula: gear ratio = motor shaft revolutions / driving shaft revolutions.

5.3.4.19 6098h Homing method

This object contains the zeroing method used by the device for the homing procedure, the permitted values are:

- 1 = Homing with zero proximity search in the positive direction and then search for the index pulse (zero of the encoder) in the negative direction.
- 2 = Homing with zero proximity search in the negative direction and then search for the index pulse (zero of the encoder) in the positive direction.
- 17 = Homing with zero proximity search in the negative direction.
- 18 = Homing with zero proximity search in the positive direction.
- 37 = Homing without zero proximity: the actual position will be the zero position.
- -1 = Homing on negative torque and index pulse (zero of the encoder): search in the negative direction for the current limit and then go in the positive direction, until zero encoder is found.
- -2 = Homing on positive torque and index pulse (zero of the encoder): search in the positive direction for the current limit and then go in the negative direction, until zero encoder is found.
- -3 = Homing on negative torque: search in the negative direction for the current limit and then stops there.
- -4 = Homing on positive torque: search in the positive direction for the current limit and then stops there.

5.3.4.20 6099h Homing speeds

This object contains the speed values used during the zero procedure.

- Fast homing speed = speed used to search for the zero proximity.
- Slow homing speed = speed used to start from the zero proximity and to find the index pulse.

5.3 Object dictionary

5.3.4.21 609Ah Homing acceleration

This object shall indicate the configured acceleration and deceleration to be used during homing operation.

5.3.4.22 60FFh Target velocity

This object contains the target velocity used during the velocity profile operation.

5.3.4.23 6502h Supported drive modes

This object shall provide information on the supported drive modes. This object is organized bit-wise. The bits have the following meaning:

- bit 0: profile position mode
- bit 1: velocity mode
- bit 2: profile velocity mode
- bit 3: profile torque mode
- bit 4: reserved
- bit 5: homing mode
- bit 6: interpolated position mode
- bit 7: cyclic synchronous position mode
- bit 8: cyclic synchronous velocity mode
- bit 9: cyclic synchronous torque mode
- bit 10-15: reserved
- bit 16-31: manufacturer-specific

The bit values have the following meaning:

- bit value = 0: mode is not supported
- bit value = 1: mode is supported

5.3 Object dictionary

5.3.5 Manufacturer custom objects

In Table 5.13 are represented the manufacturer custom objects.

Table 5.13: Manufacturer custom objects.

ID	Sub	Description	Type	Access	PDO Mapping	Default Value
2002h	0	Input Status	U32	RO	TPDO	0
2003h	0	Output Status	U32	RW	TPDO	0
2004h	0	Homing Ok	U8	RO	TPDO	0
2006h	0	Warnings	U16	RO	-	0
2020h	0	Diagnostic	U32	RO	TPDO	0

5.3.6 Manufacturer custom objects descriptions

In the following Sections are described the manufacturer custom objects.

5.3.6.1 2002h Input status

This read-only parameter contains the status of the inputs present in the drive. The bit representation is described in Table 5.14. A "0" value represents a LOW input state and a "1" value represents a HIGH input state.

Table 5.14: Input Status bit.

Bit 31-4	Bit 3	Bit 2	Bit 1	Bit 0
Reserved	Proxy	Proxy Ext	In2	In1

5.3.6.2 2003h Output status

This read-only object contains the status of the outputs present in the drive (only 1). The bit representation is described in Table 5.15. A "0" value represents a LOW output state and a "1" value represents a HIGH output state.

Table 5.15: Output Status bit.

Bit 31-1	Bit 0
Reserved	Out

5.3.6.3 2004h Homing ok

This read-only object contains the homing status.

- 1 = Homing done
- 0 = Homing not performed

5.3.6.4 2006h Warnings

This read-only object contains the possible warnings coded with 1 bit for each warning type. A complete descriptions of every bit is described in the Table 5.21

5.4 Startup parameters

5.3.6.5 2020h Diagnostic

The DIAGNOSTIC_WORD variable returns the state of both errors and warnings.

In Table 5.16 is shown the bit-field of the diagnostic word: the upper 16 bits represent the errors, while the last 16 bits represent the warnings.

Table 5.16: Diagnostic word description.

Bit	Warnings
0	VDC UVLO (< 20V)
1	VDC OVLO (> 60V)
2	VL UVLO (< 21V)
3	VL OVLO (> 27V)
4	Temperature motor limit (> 75°C)
5	Temperature drive limit (> 75°C)
6	Calibration not done
7	RESERVED
8	Homing not done
9	Target speed not reached
10	Target position not reached
11	Command refused
12 ... 15	RESERVED
Bit	Errors
16	VDC UVLO (< 10V)
17	VDC OVLO (> 80V)
18	VL UVLO (< 16V)
19	VL OVLO (> 29V)
20	Temperature motor limit (> 100°C)
21	Temperature drive limit (> 100°C)
22	Current sensors fault
23	Control fault
24	Encoder fault
25	Non volatile memory fault
26	I ² T fault
27	STO
28	Homing execution error
29	Software limits error
30 ... 31	RESERVED

5.4 Startup parameters

In Table 5.17 are listed the parameters that are sent by the PLC to the drive at the startup.

If the option "Stored Parameters" of "System Start" parameter is selected, the drive will load the startup

5.4 Startup parameters

parameters stored in internal memory, instead if the option "External" is used, the drive will use the parameters sent by the PLC. All the parameters are stored in non volatile memory upon variation.

The "Endianness" parameter allows to set the endianness of the communication between the PLC and the drive.

The "Diagnosis" parameter allows to enable or disable the diagnostic errors. The "PID Selection" parameter provides five different presets for speed and position PID controllers, that can be selected according to the specific application. For particular needs, the "PID Custom" configuration can be used and in this case, PID speed and position can be tuned using "PID Position" and "PID Speed" parameters. It is suggested to use the "Default" PID configuration when the drive has little or no load attached. Use instead the other presets, according to the entity of the load attached to the shaft.

The "Profile Check" parameter allows to control if the target speed (when in speed control) or the target position and speed (when in position control) are actually reached by the motor, during the motion execution. The "Profile Timeout" parameter, expressed in milliseconds, is the time after which the error is returned, in case target position or target speed are not reached.

Target scale factor "Numerator" and "Denominator" allow to apply a scaling to the profile parameters (i.e.: final targets are multiplied by "Numerator" and divided by "Denominator").

The "Motion direction" parameter allows to set the motor movement positive direction, clockwise or counterclockwise.

The "Actuator screw pitch" defines the value in mm that the axis moves for each motor revolution.

The "Homing parameters" allows to set the Homing speeds (fast and slow) and the acceleration (regarding it, in case of using the startup parameters by PLC, the value is unique for all homing accelerations In and Out, whilst using UVIX is possible to set 4 different values).

5.4 Startup parameters

Table 5.17: Startup parameters.

Parameter	Description	Options
Endianness	Data format used	Little Endian (INTEL) Big Endian (MOTOROLA)
System Start	Startup parameters to use	Stored Parameters External
Diagnosis	Errors diagnostic	Enabled Disabled
PID Selection		Default Low load Medium load High load Custom
PID position	Valid for Custom PID selection	KP Position KI Position
PID speed	Valid for Custom PID selection	KP Speed KI Speed
Profile	Control target speed / position reached	Check Timeout (ms)
Target scale factor	Scale factor applied to speed / position / acc / dec	Numerator Denominator
Motion direction	Set the motor rotation direction	clockwise counterclockwise
Actuator screw pitch		mm/motor revolution
Torque homing threshold	Torque limit during the homings	% of the I ² T limit value
Actuator type		Only motor Custom Actuator
Homing parameters		Fast speed Slow speed acceleration/deceleration
PDS FSA Enable	CiA402 Finite State Automa	Enabled Disabled

5.4 Startup parameters

5.4.1 Startup parameters objects

In Table 5.18 are represented the startup parameters objects.

Table 5.18: Startup parameters objects.

ID	Sub	Description	Type	Access	Default Value
8000h	1	System endianness	U8	RO	0
8000h	2	System start	U8	RO	0
8000h	3	System Emergencies Enabled	U8	RO	1
8001h	1	Pid Selection	U8	RO	1
8002h	1	KP Position	U16	RO	1
8002h	2	KI Position	U16	RO	0
8003h	1	KP Speed	U16	RO	10000
8003h	2	KI Speed	U16	RO	10
8004h	1	Profile Check	U8	RO	1
8004h	2	Profile Timeout	U16	RO	10
8005h	1	Target Scale Numerator	U16	RO	1
8005h	2	Target Scale Denominator	U16	RO	1
8006h	0	Actuator screw pitch	U32	RO	100
8007h	0	Torque Homing Threshold	U8	RO	10
8008h	0	Actuator Type	U8	RO	0
8009h	0	PDS FSA Enable	U8	RO	1

NOTE: in addition to these, it is suggested that PLC also send the Homing speeds and acceleration (parameter 6099h and 609Ah) and the motion direction (607Eh).

5.4.2 Startup parameters objects descriptions

In the following Sections are described the Startup parameters objects.

5.4.2.1 800001h System endianness

This parameter contains the byte convention used (Little Endian or Big Endian).

- 0 = Little endian
- 1 = Big endian

5.4.2.2 800002h System start

This parameter is used to decide if on startup DRVI must use the default values saved in internal memory or must use those ones sent by PLC.

- 0 = Stored parameters
- 1 = External parameters (PLC)

5.4 Startup parameters

5.4.2.3 800003h System Emergencies Enabled

This parameter enables the diagnostic messages (emergency)

- 0 = Disabled
- 1 = Enabled

5.4.2.4 800101h Pid Selection

This parameter set the PID control type

- 0 = PID default
- 1 = PID low
- 2 = PID medium
- 3 = PID high
- 4 = PID custom

5.4.2.5 800201h KP position

This parameter set the PID KP position value

5.4.2.6 800202h KI position

This parameter set the PID KI position value

5.4.2.7 800301h KP Speed

This parameter set the PID KP speed value

5.4.2.8 800302h KI Speed

This parameter set the PID KI speed value

5.4.2.9 800401h Profile Check

This parameter enables the check of the target reached position at the end of a movement

- 0 = Disabled
- 1 = Enabled

5.4.2.10 800402h Profile Timeout

This parameter set the value of the timeout after that if target position has not been reached, it will generate a warning (only if Profile check is enabled)

5.4.2.11 8005h Target Scale

These parameters (numerator and denominator) set the value of the gear factor reduction

5.5 Diagnostic behaviour

5.4.2.12 8006h Actuator screw pitch

This parameter set value of the Actuator screw pitch. NOTE: the final desired value must be multiplied by 100 when it is sent from PLC

5.4.2.13 8007h Torque Homing Threshold

This parameter set the threshold current value when the DRVI have to execute a homing procedure. The value is set as a percent of the I²T value

5.4.2.14 8008h Actuator Type

This parameter set the type of the actuator. The possible values are:

- 0 = Only motor
- 7 = Custom Actuator

5.4.2.15 8009h PDS FSA Enable

This parameter enables the CiA402 FSA (Finite State Automata) as described in the Figure 5.2. If it is disabled, some bits of the controlword have a different management:

- bit1 = if 1, it activates the Servo ON, if 0 Servo OFF
- bit2 = if 1, it activates the quick stop procedure

5.5 Diagnostic behaviour

The drive handles both errors and warnings. The difference between the two is that warnings do not impact on the drive operation (they are just signaled), whilst errors cause the motor to stop. Both errors and warnings remain latched even if the error or warning condition disappear. To reset the warning and error condition, the reset command must be given. The only warnings that auto-reset are the "homing missing" and the "command refused" ones. Errors are divided into two categories: hard and soft. Soft errors are considered less severe and they cause a controlled stop of the motor rotation by triggering the command QUICK_STOP. The drive status can be monitored by the led status (refer to Section 3.4).

Soft errors are:

- Temperature motor limit
- Temperature drive limit
- Homing execution error
- Fieldbus disconnection

All the others (see Table 5.20) are hard errors and they cause the power drives to be turned off, hence the motor finishes its rotation in idle state, that is, with no control applied.

5.5.1 Emergency Object

When the drive is in error state, it send this information through the asynchronous emergency message. Every error has its own code (ErrorCode); these codes are in turn subdivided, for example, into current errors, voltage errors, etc. The Emergency telegram is of the type shown in Table 5.19.

5.5 Diagnostic behaviour

Table 5.19: Emergency message.

Byte 0-1	Byte 2	Byte 3-7
Error Code	Error Register	reserved

- Byte 0 and 1 have inside the ErrorCode value (see Table 5.5.2).
- Byte 2 is a bit mask and every bit signals if an error of a certain type has happened.
- Byte 3 could has inside an optional subcode parameter.

5.5.2 Errcode codes and Error register bits

In Table 5.20 are shown the possible values and the description of the error codes.

Table 5.20: ErrorCode and error register bits description.

ErrCode value	Error register bit	Description
0000h	b1	Alarm Reset/No alarms
2310h	b1	Over current error
2320h	b2	I ² T fault
3110h	b2	Over voltage error VBUS (> 80V)
3111h	b2	Over voltage error VLOG (> 29V)
3120h	b2	Under voltage error VBUS (< 10V)
3121h	b2	Under voltage error VLOG (< 16V)
4210h	b3	Over temperature motor error (> 100°C)
4210h	b3	Over temperature drive error (> 100°C)
5530h	b4	Non volatile memory fault
5540h	b4	Error HW Enable is not present (STO)
6100h	b5	Control fault
6120h	b7	Software Limits exceed
7305h	b6	Encoder fault
8613h	b7	Homing execution error

To erase the errors and try to restore the drive to operational status, it is necessary to perform the following procedure:

- Reset the fault bit inside the Controlword (Figure 5.3).
- Make the NMT state machine transition to Ready to switch on.
- Make the NMT state machine transition to Switched on.
- Make the NMT state machine transition to Operation enable.

If the PDS FSA state machine is not enabled (see 5.4.2.15), the procedure to erase the errors is described below:

- Reset the fault bit inside the Controlword (Figure 5.3).
- Check that no error conditions is still present by reading the error bit of the statusword (Figure 5.4)
- Restore the enable power bit of the controlword

5.5 Diagnostic behaviour

5.5.3 Warnings

The drive can manage warnings information in the following way:

- When a warning condition happens, the bit 7 of the statusword is set.
- The user can ask to the drive to send the coded information of the active warnings, reading the object 2006h.
- The procedure to erase the warnings is the same as for the errors.

In Table 5.21 are shown the possible values and the descriptions of the warnings bits readed in the object 2006h.

Table 5.21: Diagnostic word description.

Bit	Warnings
0	VDC UVLO (< 20V)
1	VDC OVLO (> 60V)
2	VL UVLO (< 21V)
3	VL OVLO (> 27V)
4	Temperature motor limit (> 75°C)
5	Temperature drive limit (> 75°C)
6	Positive position limit reached
7	Negative position limit reached
8	Homing missing
9	Target speed not reached
10	Target position not reached
11	Command refused
12 ... 15	RESERVED

NOTE: Temperature warnings don't affect the drive functionality, but they indicate the hot surface of the motor and/or the drive.

5.6 Profile position

5.6 Profile position

The drive provides the operations for the profile position described in the CiA 402 specifications. This drive operation mode requires a specific target position, setting the velocity, acceleration and deceleration, with which to reach the target position. The target cannot be changed during a movement, the movement in progress must be terminated or interrupted before being able to set a new target.

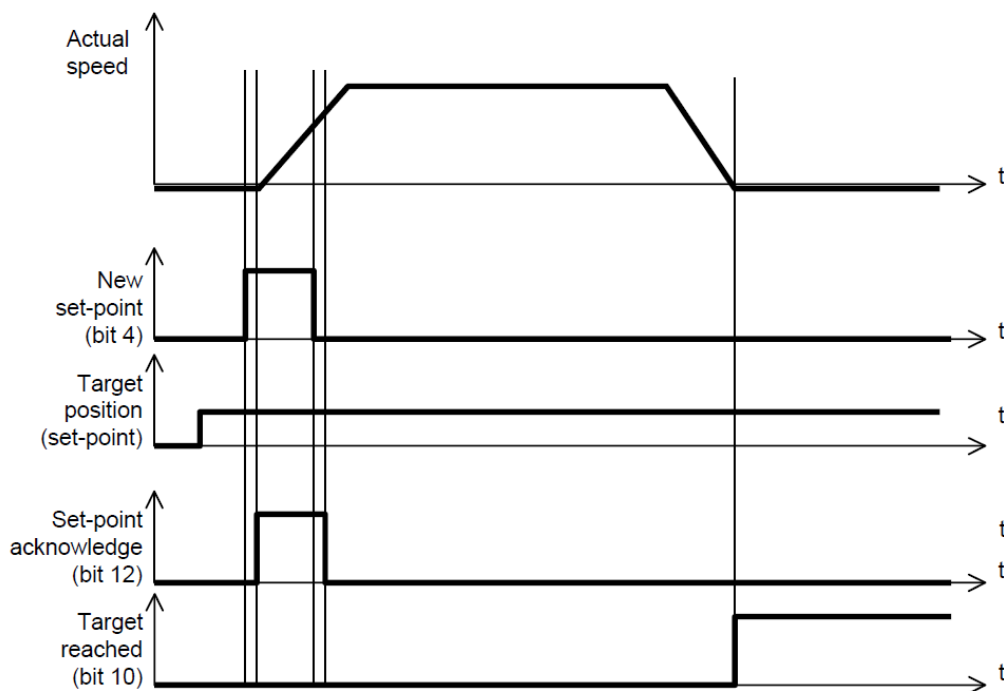

Figure 5.5: Profile position.

To enable this operation, set the operating mode to value 1 via object 6060h "Modes of operation" and check that the drive is effectively in the correct status with object 6061h "Modes of operation display".

5.6 Profile position

In this operating mode the **controlword** (profile-specific) bits become:

- Bit 4 "new set point" = this bit must be raised to indicate the start of the movement to the reach the target; the drive response on the statusword is through bit 12.
- Bit 6 "abs / rel" = this bit is used to indicate the type of movement that must be done, 0 = absolute position movement, 1 = relative position movement.

At the end of the movement the **statusword** bits become:

- Bit 10 "target reached" = this bit indicates the achievement of the target at the end of the positioning.
- Bit 12 "set-point reached" = this bit indicates that the positioning is in progress and remains high until positioning command has been completely acquired by the drive. When it is low it indicates that the drive is ready to receive a new command.

The dictionary objects related to this operating profile are listed in Table 5.22.

Table 5.22: Profile position objects.

Object	Description
6060h	"Mode of operation" to be set to value 1 to select the operating mode
607Ah	"Target position" to set the position to be reached
6081h	"Profile velocity in pp. mode" to set the velocity of the movement
6083h	"profile acceleration" to set the acceleration of the movement
6084h	"profile deceleration" to set the deceleration of the movement

The start and stop of the movement is always controlled by 2 bit of the "Controlword": transition of bit 4 from 0 to 1 will start the movement, whilst the bit 8 can be used to stop immediately the movement.

5.7 Profile velocity

5.7 Profile velocity

The drive provides the operations for the velocity profile described in the CiA 402 specifications. This drive operation mode requires a specific target velocity, acceleration and deceleration: once the velocity target is set, the motor accelerates until the target is reached and then maintains the required velocity until a new request is made (refer to Figure 5.6).

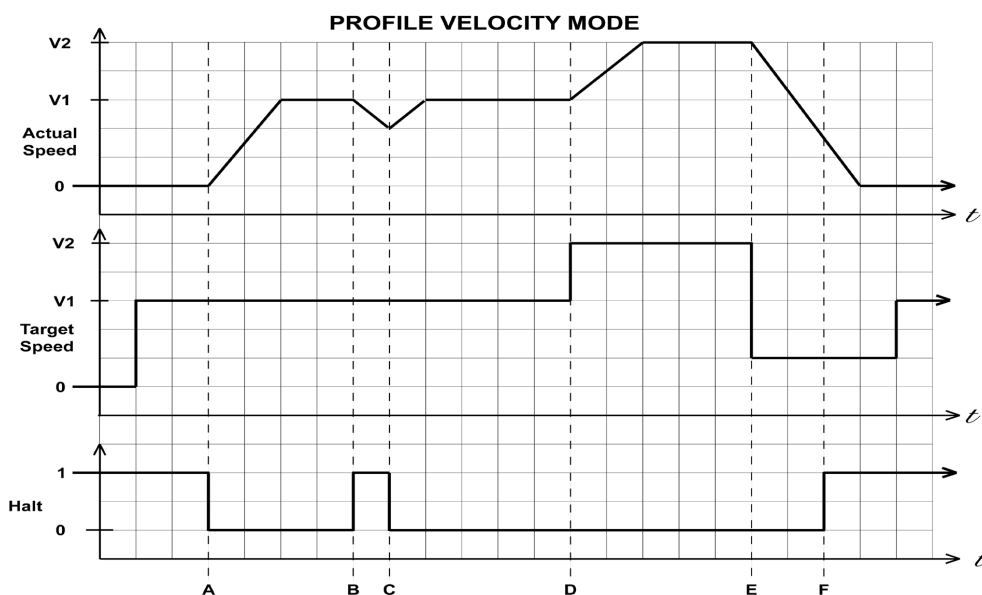

Figure 5.6: Profile velocity.

To enable this operation, set the operating mode to value 3 via object 6060h "Modes of operation" and check that the drive is effectively in the correct status with object 6061h "Modes of operation display". In this operating mode the **controlword** (profile-specific) bits become:

- Bit 4 "new set point" = this bit must be raised to indicate the start of the movement to the reach target, the drive response on the statusword is through bit 10.
- Bit 8 "halt bit" = this bit is used to stop immediately the movement: 0 = continue the movement, 1 = stop the movement.

The **statusword** is updated as follows:

- Bit 10 "target reached" = with the "halt" bit equal to zero this bit indicates the achievement of the velocity target, with the "halt" bit equal to one this bit indicates if motor is stopped: 1 = motor stopped, 0 = motor decelerating.
- Bit 12 "speed" this bit indicates if motor is stopped: 1 = motor stopped, 0 = motor moving.

The dictionary objects related to this operating profile are listed in Table 5.23.

Table 5.23: Profile velocity objects.

Object	Description
60FFh	"Target velocity" to set a velocity target and then start the movement
6083h	"Profile acceleration" to set the acceleration profile
6084h	"Profile deceleration" to set the deceleration profile

5.8 Profile Torque

5.8 Profile Torque

The drive provides the operations for the Profile Torque mode described in the CiA 402 specifications. To enable this operation, set the operating mode to value 4 via object 6060h "Modes of operation" and check that the drive is effectively in the correct status with object 6061h "Modes of operation display".

In this operating mode the **controlword** (profile-specific) bits become as shown in Figure 5.7:

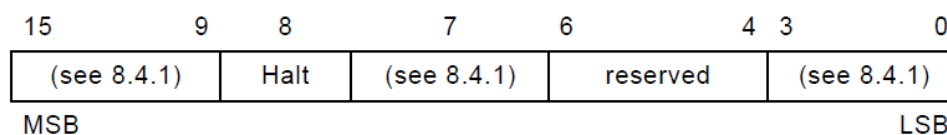

Figure 5.7: Control word for torque mode profile.

Table 5.24: Control word - definition of bit 8.

Bit	Value	Definition
8	0	The motion shall be executed or continued
	1	Stop the motor movement

The **statusword** is updated as shown in Figure 5.8:

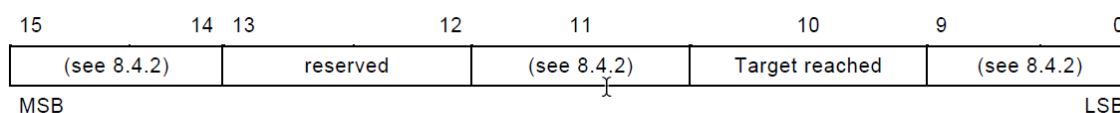

Figure 5.8: Status word for torque mode profile.

Table 5.25: Status word - definition of bit 10.

Bit 10	Value	Definition
10	0	Halt (bit 8 in controlword) = 0: Target torque not reached Halt (bit 8 in controlword) = 1: Axis decelerates
	1	Halt (bit 8 in controlword) = 0: Target torque reached Halt (bit 8 in controlword) = 1: Velocity of axis is 0

5.9 Homing mode

The drive provides the operations for the Homing mode described in the CiA 402 specifications. Homing is the procedure by which the motor searches for the zero position (e.g.: identified by the zero proximity position). From this position the counting of all movements starts. This is the procedure that must be performed immediately after startup to setup correctly the motor position.

To enable this operation, set the operating mode to value 6 via object 6060h "Modes of operation" and check that the drive is effectively in the correct status with object 6061h "Modes of operation display".

In this operating mode the **controlword** (profile-specific) bits become as shown in Figure 5.9:

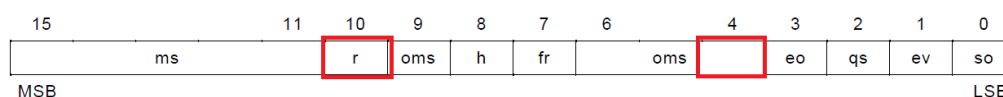

Figure 5.9: Control word for homing mode.

5.9 Homing mode

Table 5.26: Control word - definition of bit 4 and bit 8.

Bit	Value	Definition
4	0	Do not start homing
	1	Start homing
10	0	Enable bit 4
	1	Stop the motor movement

The **statusword** is updated as shown in Figure 5.10:

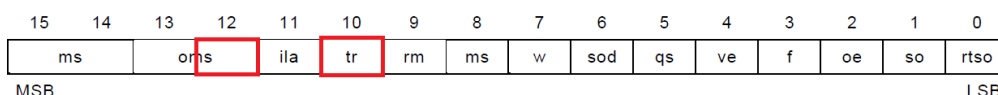

Figure 5.10: Status word for homing mode.

Table 5.27: Status word - definition of bit 10 and bit 12.

Bit 12	Bit 10	Definition
0	0	Homing procedure is in progress or turn on condition
0	1	Homing procedure is interrupted or not started
1	0	Homing is attained, but target is not reached
1	1	Homing procedure is completed successfully

The 2004h "Homing Ok" dictionary object contains the drive homing status:

- 0 = homing not performed.
- 1 = homing done (ready for movement commands).

To configure the execution movement of the homing procedure, the following objects must be configured as shown in Table 5.28:

Table 5.28: Homing mode objects.

Object	Description
6060h	"Mode of operation" to set the homing mode
609901h	"Homing velocity fast speed" velocity for proximity search
609902h	"Homing velocity slow speed" proximity out velocity
6098h	"Homing method" the number of the type of homing that must be performed
609Ah	"Homing acceleration" set the acceleration/deceleration to be used during the homing movement
607Ch	"Home offset" offset to be applied to the physical zero position to move the motor zero

NOTE: in case of Torque Homings, in addition to the start bit, it is necessary to set also the torque limit bit inside the controlword

In Table 5.29 is shown the correspondence between the homing object 6060h value and the modes of operation described in Chapter 4.

5.10 Jog mode

Table 5.29: Supported homing types.

Value (object 6060h)	Mode of operation
1	Proximity homing: negative direction + zero encoder
2	Proximity homing: positive direction + zero encoder
17	Proximity homing: negative direction
18	Proximity homing: positive direction
37	Positioning homing
-1	Torque homing: negative direction + zero encoder
-2	Torque homing: positive direction + zero encoder
-3	Torque homing: negative direction
-4	Torque homing: positive direction

5.10 Jog mode

This operation mode makes it possible to move the drive in speed mode using 2 bits of the controlword. To enable this operation, set the operating mode to value 14 via object 6060h "Modes of operation" and check that the drive is effectively in the correct status with object 6061h "Modes of operation display". In this operating mode the **controlword** (profile-specific) bits become as shown in Figure 5.11:

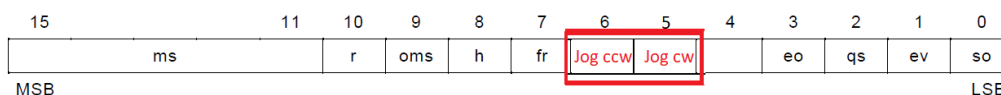

Figure 5.11: Control word for jog mode.

Table 5.30: Control word - definition of bit 5 and bit 6.

Bit 6	Bit 5	Definition
0	0	Stop (zero speed)
1	0	Clockwise rotation
0	1	Counter-clockwise rotation
1	1	Invalid command (previous state persists)

The **statusword** is updated as shown in Figure 5.12:

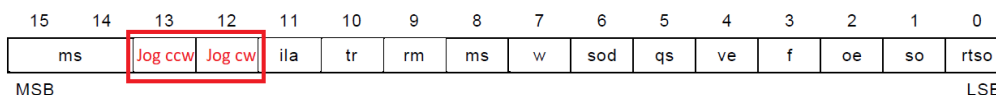

Figure 5.12: Status word for jog mode.

Table 5.31: Status word - definition of bit 12 and bit 13.

Bit 13	Bit 12	Definition
0	0	Jog OFF
0	1	Jog movement Clockwise
1	0	Jog movement Counter-clockwise
1	1	Forbidden state

To configure the execution jog movements, the following objects must be configured as shown in Table 5.32:

5.11 Inputs GPIO

Table 5.32: Jog mode objects.

Object	Description
6060h	"Mode of operation" to set the Jog mode
60FFh	"Target velocity" set the target speed used during jog movements
6083h	"Profile acceleration" set the acceleration to be used during the jog movements
6084h	"Profile deceleration" set the deceleration to be used during the jog movements

5.11 Inputs GPIO

The status of the input GPIOs present on the I/O connector (refer to Chapter 3.3.2) can be monitored according to the bitmask described in Table 5.33. A "0" value indicates an input LOW state while a "1" value indicates an input HIGH state.

Table 5.33: Input GPIO bitmask.

Bit	Description
0	IN1
1	IN2
2	PROXY EXT
3	PROXY INPUT

The inputs status can be read with the CoE object 0x2002 Input Status.

5.12 Output GPIO

The status of the output GPIO present on the I/O connector (refer to Chapter 3.3.2) can be changed according to the bitmask described in Table 5.34.

Table 5.34: Output GPIO bitmask.

Bit	Value	Description
0	0	OUT LOW
0	1	OUT HIGH

The output status can be modified with the CoE object 0x2003 Output Status.

Uvix

6.1 Introduction

Camozzi's proprietary environment, called UVIX, allows the user to monitor and configure all new generation Camozzi devices (*Camozzi Smart Devices*) that support connection to it. Devices can be connected to UVIX via USB. This system has been implemented with a web-based architecture so that information can be accessed straightforwardly using a browser. Monitoring consists of displaying all the device variables, whether they relate to operation, diagnostics, or parameterization.

For details on the UVIX architecture, its installation, and general operations, see the [UVIX Manual](#).

6.2 General information

6.2 General information

The devices connected to the UVIX are displayed in a tree diagram **1** consisting of *Device Groups*, *Family* and *Devices*. Select one of the components to view in the main window **2** all the information on the various devices and perform configuration operations or manual commands.

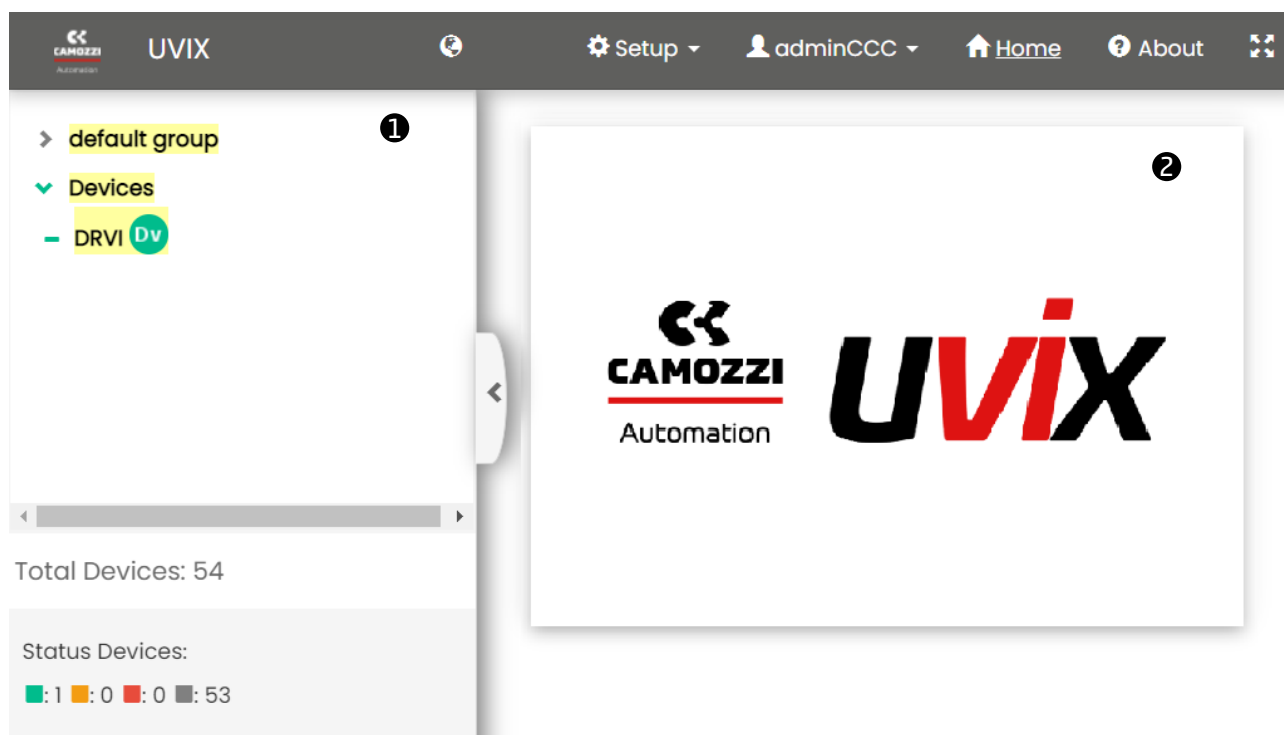

Figure 6.1: Main page of the UVIX interface.

Select the DRVI device to view the general status information and details (variables, alarms, and commands). Furthermore, it is possible to set the DRVI parameters and to communicate with the device in real-time (*Commissioning*).

6.3 Status information

6.3 Status information

- ❶ Image of the DRVI series.
- ❷ Assigned name of the device.
- ❸ Identification number of the device (17 chars).
- ❹ Family name of the device: *Series Integrated Foc Drive*.
- ❺ Subtype of the device family: *Drvi Stepper/Brushless Motor*.
- ❻ Firmware version.
- ❼ Date and time of the last data transmission.
- ❽ General status of the device: ● Not available, ● Ok, ● Warning, ● Alarm.
- ❾ Operational status of the device:
 - *Work*: normal operation.
 - *Manual*: manual operation.
- ❿ Connection status: ● Ok, ● Offline.
- ⓫ Fieldbus communication: Profinet/EtherCAT/CANopen.
- ⓬ Communication status of the Fieldbus: ● Ok, ● Offline.
- ⓭ Fieldbus configuration (par. ??).
- ⓮ DRVI parameters configuration (par. 6.5).
- ⓯ Commissioning device (par. 6.6).

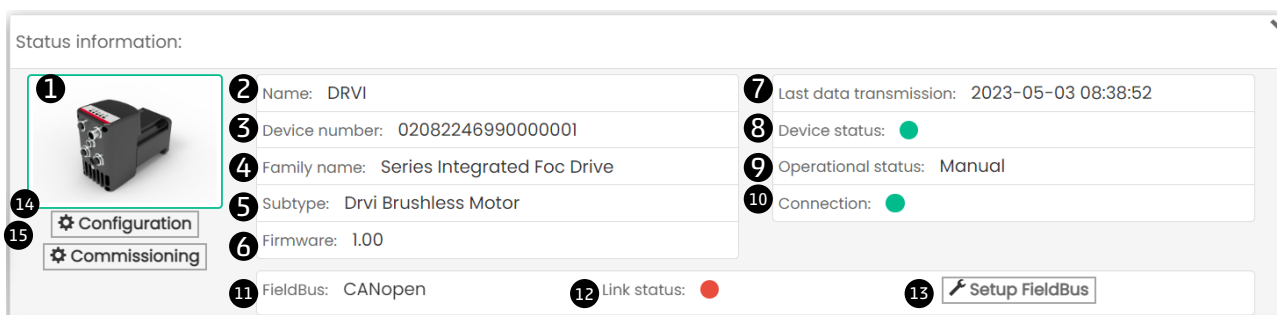

Figure 6.2: Main page of the UVIX interface.

6.4 Details



6.4.1 Variables

The first tab of the details page deals shows the variables that are monitored by the DRVI device as shown in Figure 6.3.

- Motor Size: *Nema 17, Nema 23, Nema 24.*
- Brake: *Present or Not present.*
- STO: *Present or Not present.*
- Actuator type:
 - *Only motor*
 - *Custom actuator*
- V Logic: supply voltage for the device controller circuit board. Without this supply voltage, the device is turned off.
- V Bus: bus voltage in.
- T Motor: motor temperature in °C.
- Servo state: *On or Off.*
- Mode of operation:
 - *Homing*
 - *Speed*
 - *Relative positioning*
 - *Absolute positioning*
 - *Torque*
- Busy state: *True or False.*
- Homing state: *Present or Not present.*
- Actual pos: actual position measured in angular degrees or mm.
- Actual vel: actual velocity measured in RPM or mm / s.
- Actual torque: actual torque (current) measured in mA.
- Total stroke: total stroke measured in m.
- Total time on: total time on measured in hours.
- Total time off: total time off measured in hours.
- Total time run: total time run measured in hours.
- Power: power consumption measured in watt hour.
- Output GPIO: *On or Off.*
- Input 1: *On or Off.*
- Input 2: *On or Off.*
- Input proxy external: *On or Off.*
- Input proxy homing: *On or Off.*

6.4.2 Alarms

The second tab on the details page displays possible DRVI alarms as shown in Figure 6.4.

- Error alarms: *Alarm active* , *Alarm not active*  .
 - *VBUS under voltage.*

6.4 Details

- VBUS over voltage.
- VLOG under voltage.
- VLOG over voltage.
- Motor temperature.
- Drive temperature,
- Over current.
- Fault in control loop.
- Encoder fault.
- Non-volatile memory fault.
- Energy dissipation fault.
- STO fault.
- Homing fault.
- Warning alarms: *Alarm active* ⚠, *Alarm not active* ⚠.
 - VBUS under voltage.
 - VBUS over voltage.
 - VLOG under voltage.
 - VLOG over voltage
 - Motor temperature.
 - Drive temperature.
 - Homing not done.
 - Target speed not reached.
 - Target position not reached.
 - Invalid command.
 - Position limit reached.

6.4 Details

Details: ▼

▮ Variables
🔔 Alarms
📜 Commands

Name	Value
Motor size	Nema 23
Brake	Not present
STO	Not present
Actuator type	Only motor
V Logic	23.3 V
V Bus	23.7 V
T Motor	27.8 °C
Servo state	On
Mode of operation	Homing

Figure 6.3: Section for the variables monitored by the DRVI device.

Details: ▼

▮ Variables
🔔 Alarms
📜 Commands

Event Name	Status ▼	Event Onset
Drive temperature	🔻	
Over current	! (red)	
Fault in control loop	! (red)	
Encoder fault	! (red)	
Non-volatile memory fault	! (red)	
Energy dissipation fault	! (red)	
VBUS under voltage	⚠️ (yellow)	
VBUS over voltage	⚠️ (yellow)	
VLOG under voltage	⚠️ (yellow)	

Figure 6.4: Section for the alarms monitored by the DRVI device.

6.4 Details

6.4.3 Commands

The third tab of details on the DRVI device shows the commands that can be sent via UVIX to the device. The *Manual Mode* command allows you to control the system manually from UVIX, sending configuration parameters to the DRVI. In manual mode, it is possible to reset the alarms ❶, to set the digital output ❷, to start or stop the motor movement ❸, and to switch on/off the servo ❹. The history of the commands sent to the DRVI since the communication with UVIX was started can be viewed under Last Commands ❺.

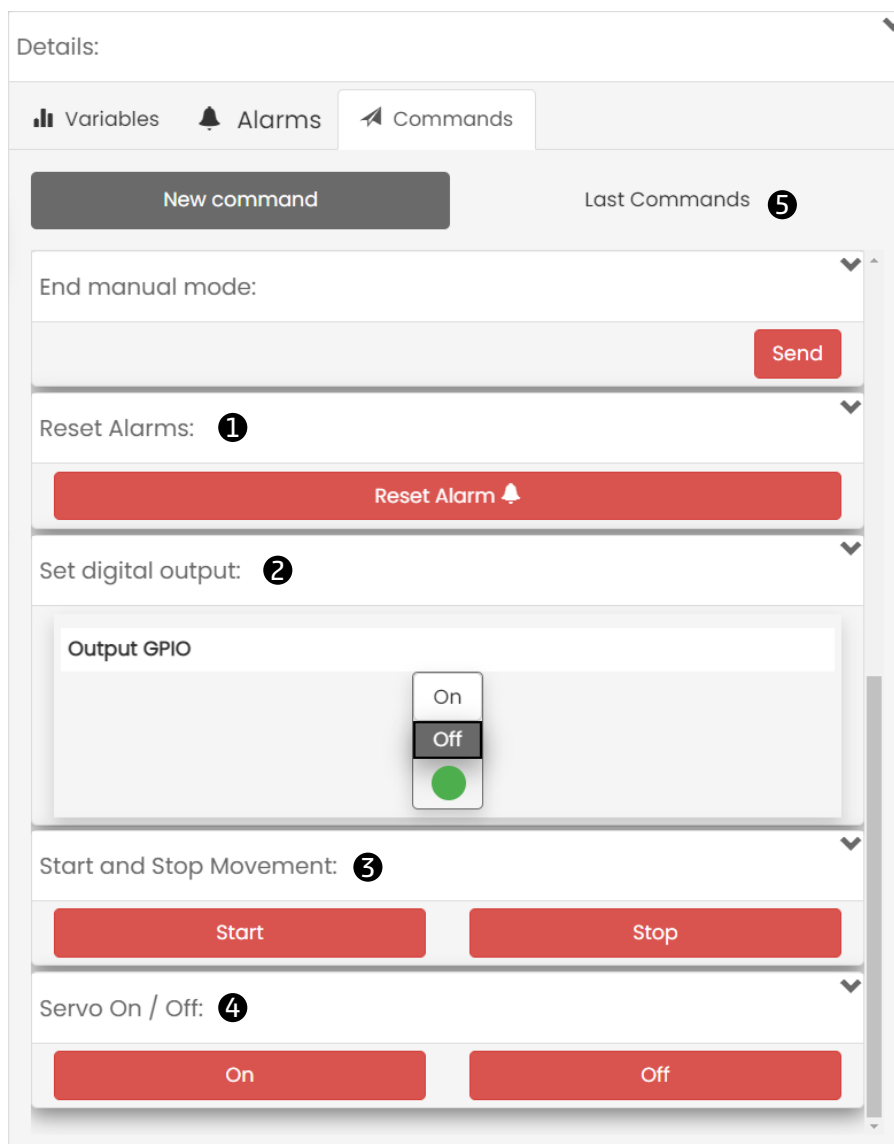

Figure 6.5: Section for the commands managed by the DRVI device.

6.5 Configuration

6.5 Configuration

From the status information page, you can configure certain operating-related parameters of the DRVI: actuator, motion and communication. All these parameters can be stored into the non volatile memory of the drive by clicking the buttons "Send" and subsequently "Save on device".

6.5.1 Actuator

In the actuator section it is possible to set the following parameters:

- ❶ The type of actuator:
 - *Only motor*
 - *Custom Actuator*
- ❷ Gear ratio. If a gear is placed between the drive and the actuator, you can use this parameter to apply an automatic scale of the target (i.e.: profile parameters are multiplied by the gear ratio value).

The following items are software limits, that can be used to restrict the profile parameters:

- ❸ Actuator screw pitch measured in mm / round. This parameter allows the conversion to linear measurement units, when an actuator is connected to the drive.
- ❹ Actuator limits (if ON, it enables to modify the limit values).
- ❺ Actuator minimum stroke measured in mm (such value must be lesser than ❻).
- ❻ Actuator maximum stroke measured in mm (such value must be greater than ❺).
- ❼ Actuator max speed measured in mm / s.
- ❽ Actuator max acceleration measured in mm / s².
- ❾ Actuator max deceleration measured in mm / s².

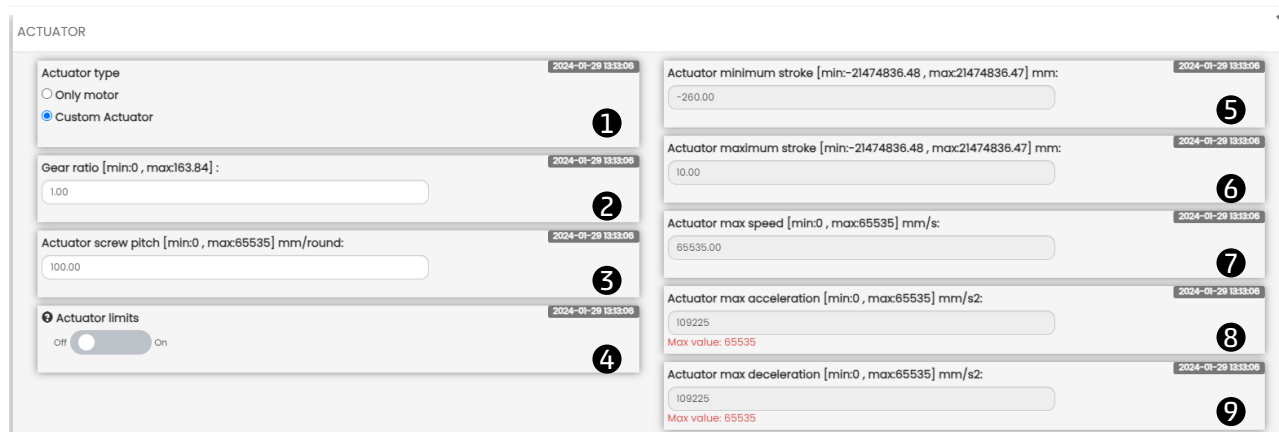

Figure 6.6: Section for actuator configuration.

6.5.2 Motion

In the motion section is possible to set the follows parameters:

- ❿ Profile check: *No* or *Yes*. Enable or disable the check of the actual rotor position, with respect to the target imposed.
- ⓫ Direction of movements: *standard* or *inverse* (with respect to convention, see Paragraph 5.1).

6.5 Configuration

- 11 Profile check timeout measured in ms. If "Profile check" is enabled, this parameters represents the time after which an error is returned, if the actual rotor position does not match the imposed one.
- 12 Quick stop deceleration measured in mm / s².
- 13 Hardware jog mode *No* or *Yes*. Enable or disable the jog mode.

MOTION

Figure 6.7: Section for motion configuration.

6.5.3 Communication

In the communication section it is possible to set the data endianness used by the fieldbus 13 : *little endian* or *big endian*.

Figure 6.8: Section for communication configuration.

6.5.4 GPIO

In the GPIO section it is possible to set the polarity of the I/O.

GPIO

Figure 6.9: Section for I/O polarity.

6.6 Commissioning

From the commissioning page it is possible to move the drive, as well as configure some of its parameters. Homing parameters and PID configuration can be stored into the non volatile memory of the drive by clicking the buttons "Send" and subsequently "Save on device".

6.6.1 DRVI states

- ❶ States of the DRVI: it is possible to watch the state of the DRVI, the state of the inputs, set the state of the output and if a fault is active
- ❷ Variables measured in fast mode.
- ❸ Command of the manual mode: *Start or End*.
- ❹ Command of the servo: *On or Off*.
- ❺ Mode operation:
 - *None*
 - *Homing*
 - *Speed*
 - *Absolute position*
 - *Relative position*
 - *Torque*
- ❻ Start and stop of the movement: *Start, Stop*.
- ❼ Reset errors and warnings: *Reset Alarm*.

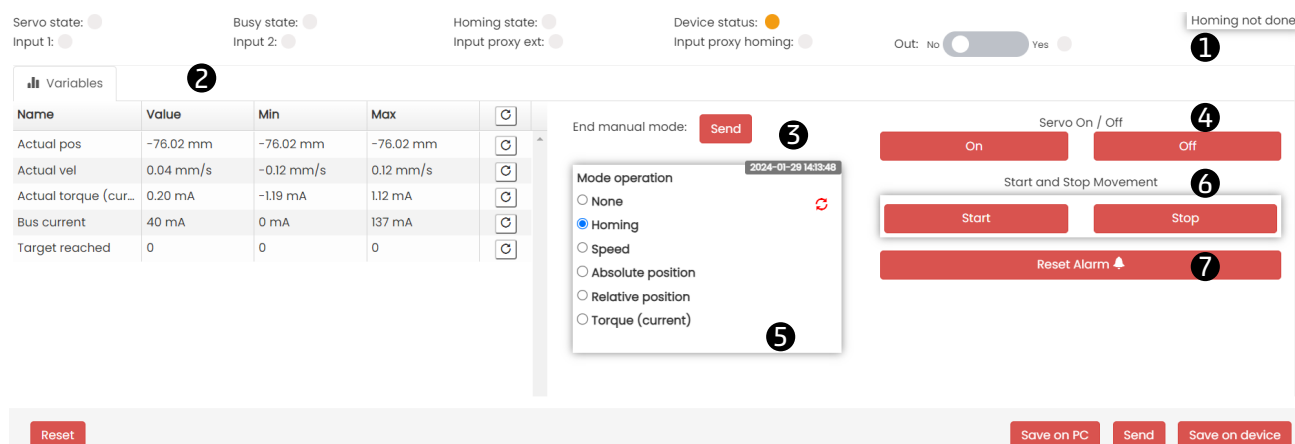

Figure 6.10: Section of the fast mode variables and DRVI states.

In case the mode of operation ❺ is set to Speed, Absolute position, Relative position or Torque the Start and Stop Movement ❻ change as in Figure below.

- ❶ Start Profile1: this is the first target value.
- ❷ Start Profile2: this is the (optional) second target value.
- ❸ Stop: it ends the current movement.
- ❹ Timeout: it set the delay in seconds between profile1 and profile2 target. BE CAREFUL: set a value that is greater than the time elapsed to execute the movement set with profile1 and profile2 target
- ❺ Loop cycle *No, Yes*: it enables the loop of movements between profile1 and profile2 target.

6.6 Commissioning

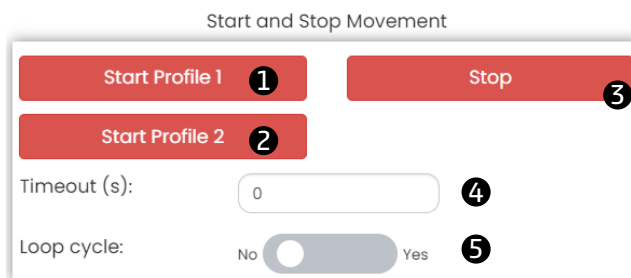

Figure 6.11: Section of the Start and Stop for not Homing modes.

6.6.2 Mode operation parameters

6.6.2.1 Homing

- ⑧ Homing type:
 - Without proximity
 - Proximity left
 - Proximity right
 - Proximity left + zero encoder
 - Proximity right + zero encoder
 - Torque left
 - Torque right
 - Torque left + zero encoder
 - Torque right + zero encoder
- ⑨ Homing speed search measured in RPM or mm / s.
- ⑩ Homing acceleration search measured in RPM / s or mm / s².
- ⑪ Homing deceleration search measured in RPM / s or mm / s².
- ⑫ Homing speed out measured in RPM or mm / s.
- ⑬ Homing acceleration out measured in RPM / s or mm / s².
- ⑭ Homing deceleration out measured in RPM / s or mm / s².
- ⑮ Homing timeout measured in ms.
- ⑯ Homing offset measured in angular degrees or mm.
- ⑰ Torque homing threshold % with respect to the I²T value.

Homing "search" parameters (e.g.: "Homing speed search") are the ones used to find the proximity (or the end of the line), while "out" parameters (e.g.: "Homing speed out") are the ones used to exit from the proximity (or the end of the line).

6.6 Commissioning

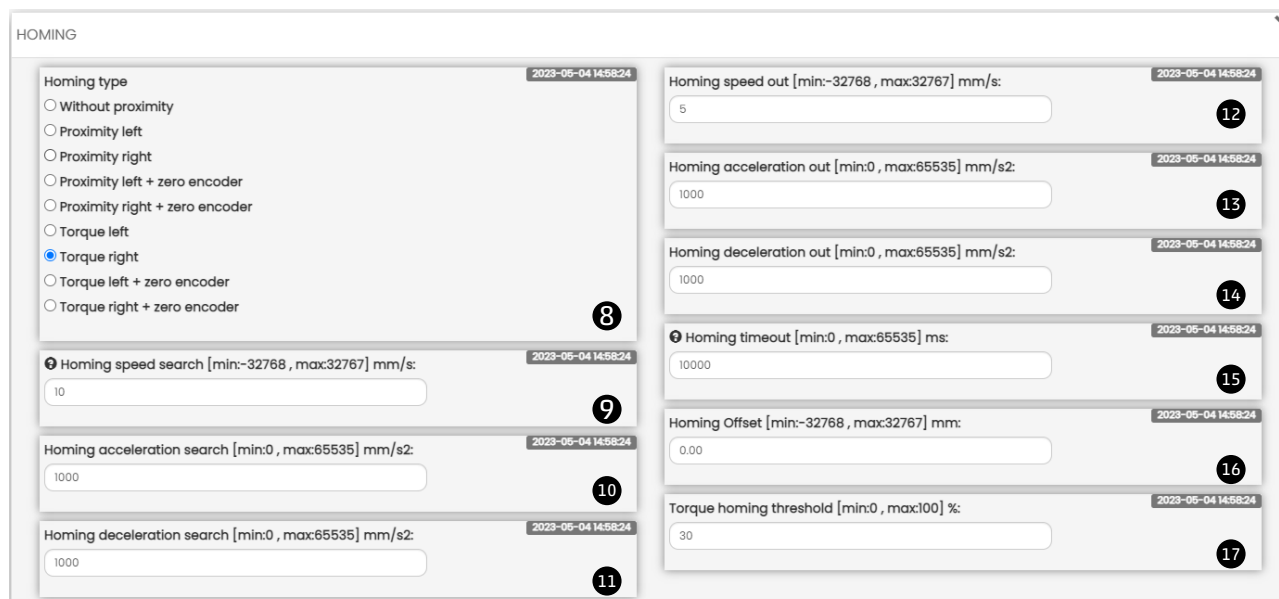

Figure 6.12: Section of the homing parameters.

6.6.2.2 Speed Profile

In the speed profile section it is possible to set the motion profile parameters for the speed control for 2 target speed, profile1 and (optional) profile2. Moreover it is possible to enable/disable the check of the Torque limit and its threshold value in mA:

- ⑧ Target speed measured in RPM or mm / s.
- ⑨ Target acceleration measured in RPM / s or mm / s².
- ⑩ Target deceleration measured in RPM / s or mm / s².
- ⑪ Torque limit enable *No*, *Yes* ².
- ⑫ Target torque limit measured in mA ².

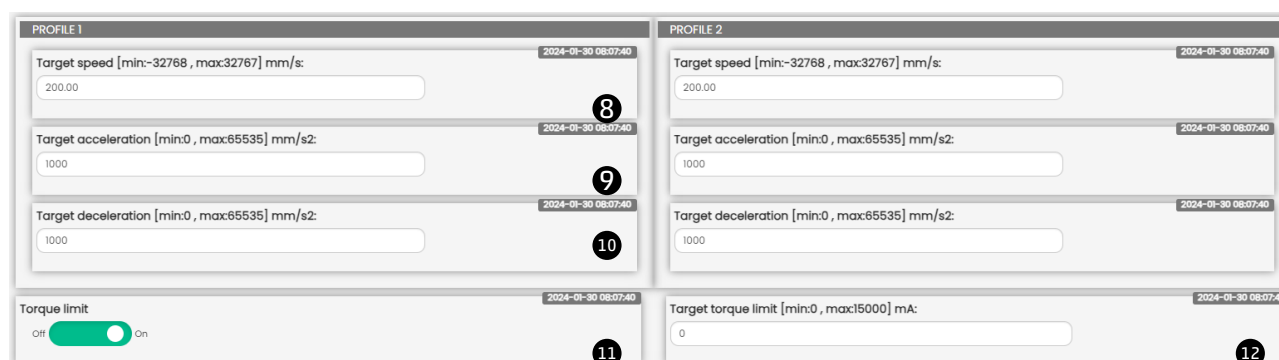

Figure 6.13: Section of the speed profile parameters.

6.6.2.3 Absolute position

In the absolute position section it is possible to set the motion profile parameters for the absolute position control for 2 target positions, profile1 and (optional) profile2. Moreover it is possible to enable/disable the check of the Torque limit and its threshold value in mA:

- ⑧ Target speed search measured in RPM or mm / s.
- ⑨ Target acceleration measured in RPM / s or mm / s².

6.6 Commissioning

- 10 Target deceleration measured in RPM / s or mm / s².
- 11 Target position measured in angular degrees or mm.
- 12 Torque limit enable *No*, *Yes*².
- 13 Target torque limit measured in mA².

ABSOLUTE POSITION PROFILE

Figure 6.14: Section of the absolute position profile parameters.

6.6.2.4 Relative position

In the relative position section it is possible to set the motion profile parameters for the relative position control for 2 target positions, profile1 and (optional) profile2. Moreover it is possible to enable/disable the check of the Torque limit and its threshold value in mA:

- 8 Target speed search measured in RPM or mm / s.
- 9 Target acceleration measured in RPM / s or mm / s².
- 10 Target deceleration measured in RPM / s or mm / s².
- 11 Target position measured in angular degrees or mm.
- 12 Torque limit enable *No*, *Yes*².
- 13 Target torque limit measured in mA².

RELATIVE POSITION PROFILE

Figure 6.15: Section of the relative position profile parameters.

6.6 Commissioning

6.6.2.5 Torque profile

In the torque profile section it is possible to set the motion profile parameters for the torque (current) control for 2 target positions, profile1 and (optional) profile2:

- ⑧ Target torque (current) measured in mA.
- ⑨ Target slope acceleration measured in mA / s.
- ⑩ Target slope deceleration measured in mA / s.

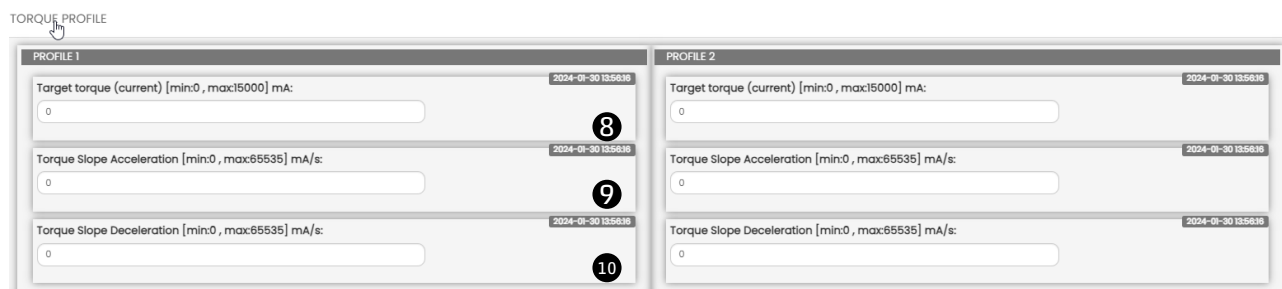

Figure 6.16: Section of the torque profile parameters.

6.6.3 PID

The PID section allows to set the PID values used in motion profiles ⑰ :

- Default
- Low load
- Medium load
- High load
- Custom

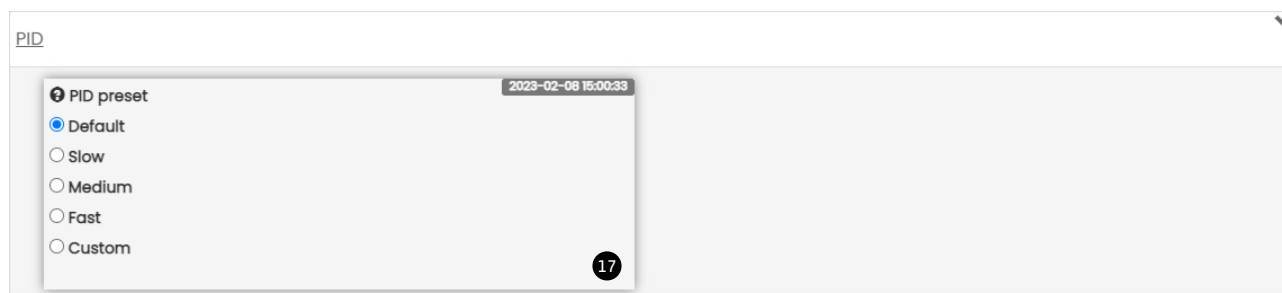

Figure 6.17: Section of the PID control.

PID parameters can be fully customized (see Figure 6.18):

- ⑱ KP speed
- ⑲ KI speed
- ⑳ KP position

6.7 EtherCAT configuration

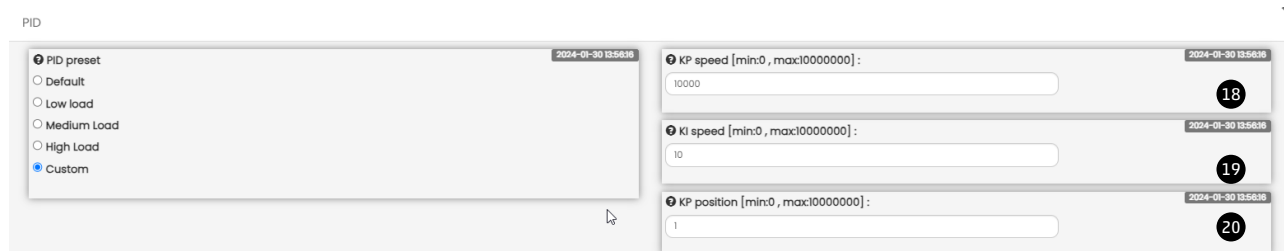

Figure 6.18: Section of the custom PID control.

6.7 EtherCAT configuration

From the status information page, you can access the window for configuring the station alias **1** fieldbus parameter. Using the buttons in the bottom bar of the configuration window **2**, the configured parameters can be sent to the module, saved on the PC, saved on the device, or reset to default values.

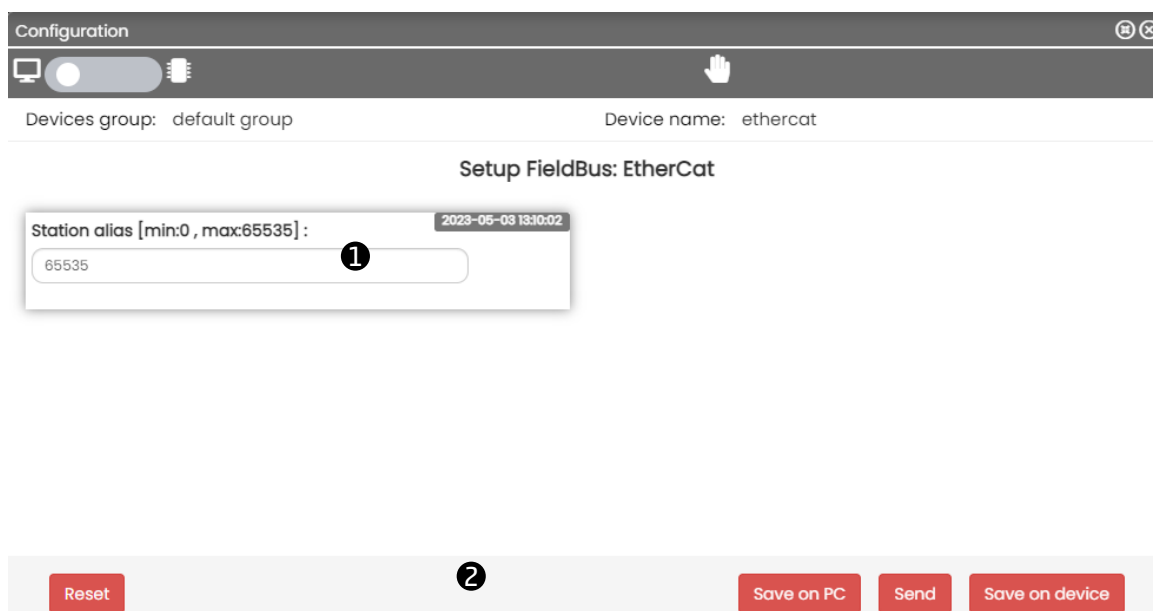

Figure 6.19: Section of the EtherCAT parameters configuration.

The fieldbus default values are shown in Table 6.1.

Table 6.1: Fieldbus default values.

Parameter	Value
Station alias	65535

6.8 UVIX USB Gateway

6.8 UVIX USB Gateway

The DRVI can be connected to a PC via a USB cable. This connection - subject to prior installation of UVIX on the PC - allows you to communicate with the module through the Camozzi USB Gateway.

6.8.1 Main page

- ① Toolbar: for managing all the functionalities of the USB Gateway.
- ② USB Gateway Commands: to start or stop the USB Gateway and open the webApp.
- ③ Status: indicates the status of the USB Gateway.
- ④ Open COMs: List of devices currently communicating.
- ⑤ Virtual COM ports available and addresses of TCP connection for the connected COM ports.
- ⑥ Data received from the COM port
- ⑦ Data received on the FEP of the UVIX system.

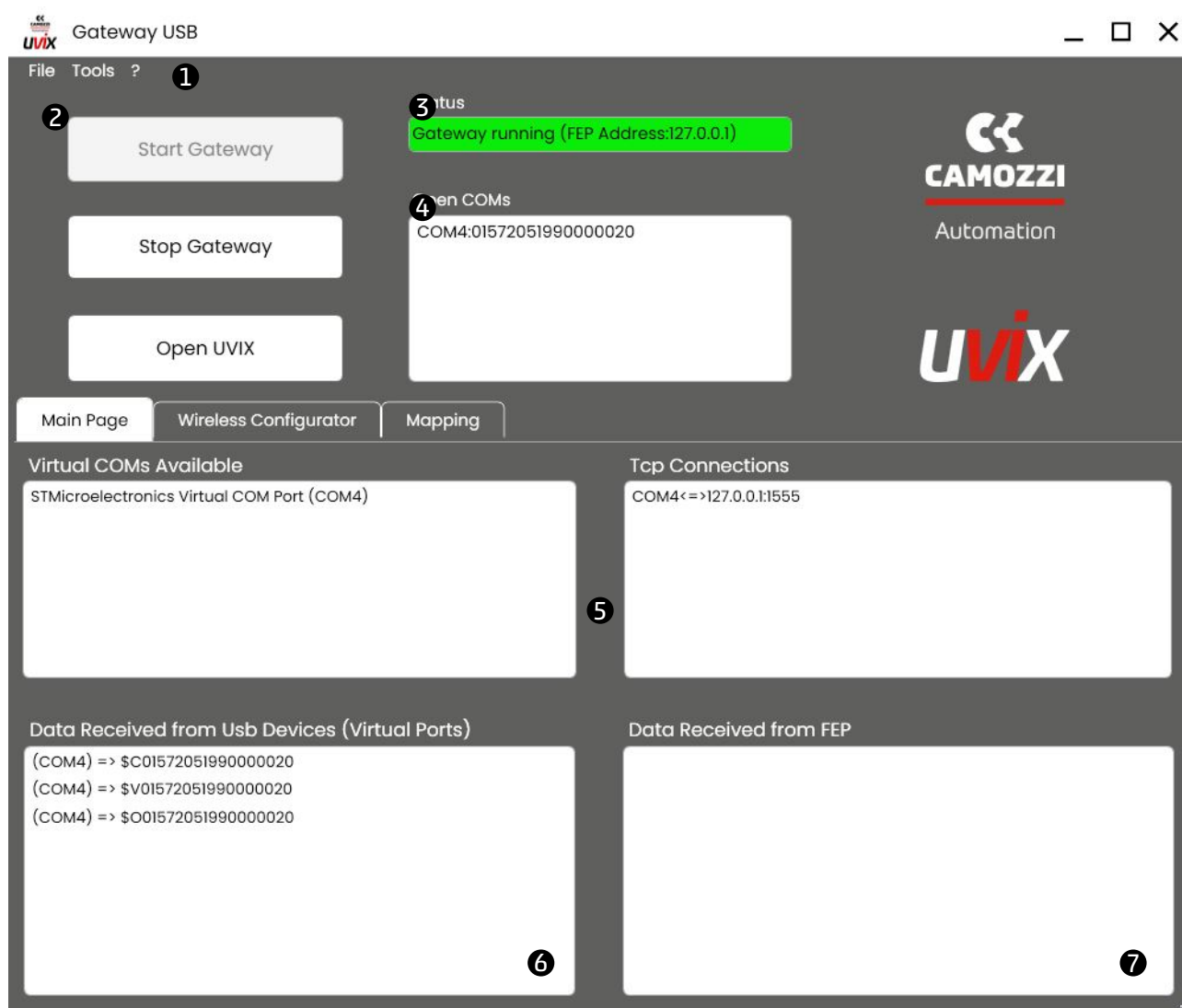

Figure 6.20: Gateway USB.

6.8 UVIX USB Gateway

6.8.2 Firmware update

⚠ Before carrying out this operation, you must contact Camozzi support.

The USB Gateway allows you to update the firmware of the DRVI module through the window found under Tools -> Device Upgrade (NO DFU) **8** (see Figure 6.21).

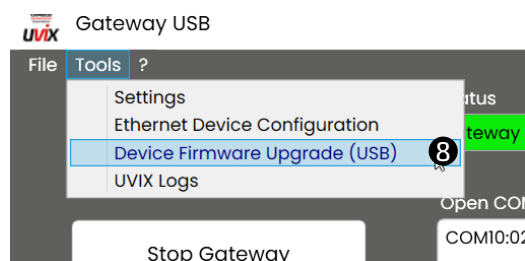

Figure 6.21: Firmware upgrade selection.

The device update window will appear (see Figure 6.22):

- **1** Current FW version.
- **2** Device to be upgraded.
- **3** Button to select binary firmware file.
- **4** New firmware binary file.
- **5** Start upgrade procedure.

Drives Upgrade

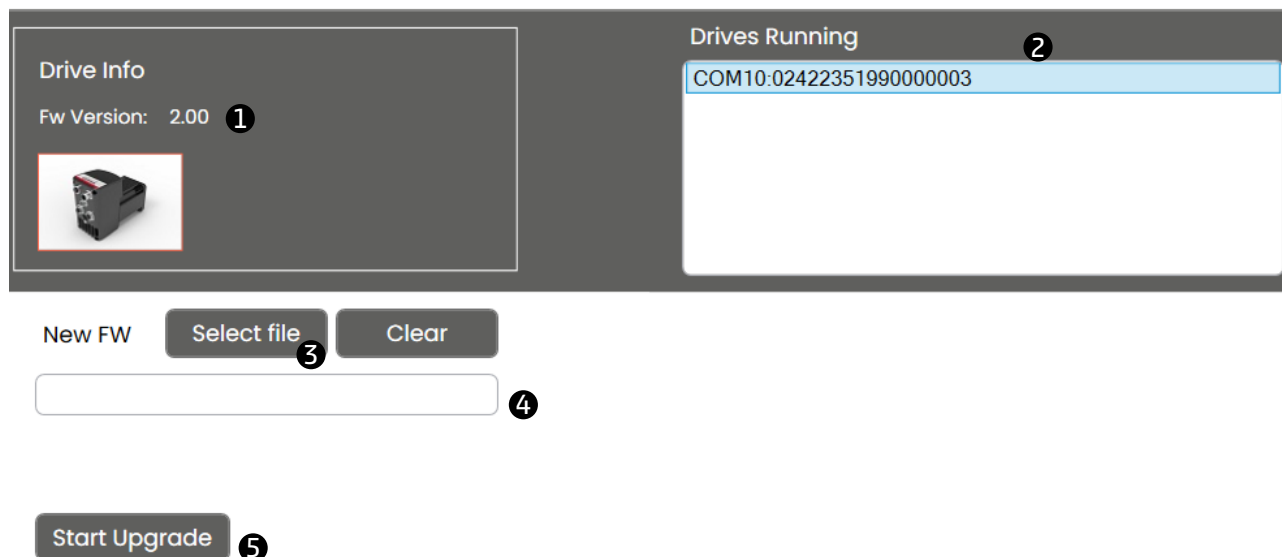

Figure 6.22: Firmware upgrade window.

Contacts

Camozzi Automation S.p.A.

REGISTERED OFFICE:

Via R. Rubattino, 81 - 20134 Milano (Italy)
P.IVA IT 03207930177

OPERATIONAL HEADQUARTERS:

Via Eritrea, 20/I - 25126 Brescia (Italy)
Tel. +39 03037921 | Info@camozzi.com
www.camozzi.com

Technical assistance

Tel. +39 030 3792790
service@camozzi.com

Product certification

Information concerning product certifications,
EC standards, conformity declarations and instructions
productcertification@camozzi.com



Automation

