

USE AND MAINTENANCE MANUAL

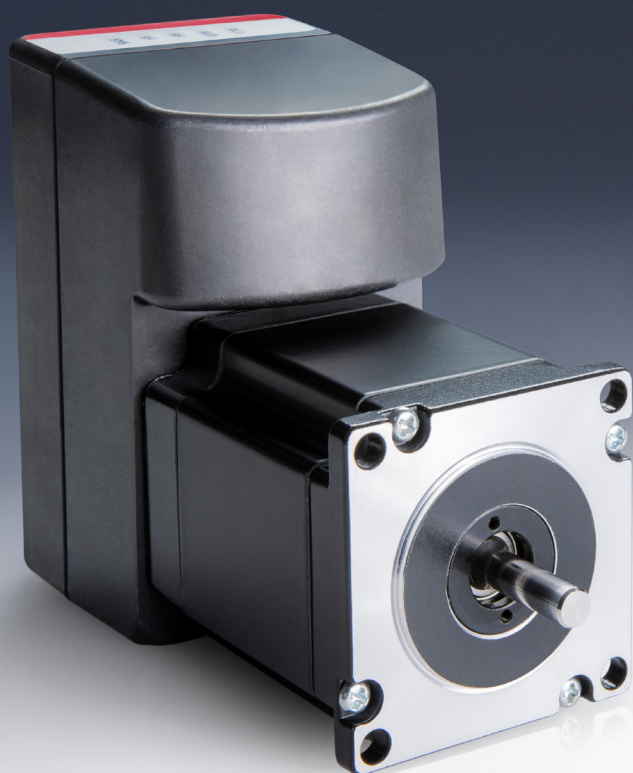

SERIE DRVI PROFINET V 1.3



Contents

Chapter 1 General recommendations	1
1.1 Product storage and transport	2
1.2 Use	2
1.3 Limitations of use	2
1.4 Maintenance	2
1.5 Ecological Information	3
Chapter 2 Introduction	4
2.1 About this manual	4
2.2 Unit overview	4
Chapter 3 Technical data	5
3.1 Environmental conditions	5
3.2 Electrical specifications	5
3.2.1 Power supply	5
3.2.2 Wiring	6
3.2.3 Encoder	6
3.3 Electrical connections	7
3.3.1 1 - Power supply	8
3.3.2 2 - GPIO	8
3.3.3 3 - STO (NOT CERTIFIED)	10
3.3.4 4, 5 - Ethernet fieldbus interface	11
3.3.5 6 - USB interface	12
3.3.6 Earth connection	12
3.4 LED indicators	12
Chapter 4 Operation Modes	14
4.1 Fieldbus Modes	14
4.1.1 Speed	14
4.1.2 Positioning	15
4.1.2.1 Relative Positioning	16
4.1.2.2 Absolute Positioning	16
4.1.3 Torque	16
4.1.4 Jog	17
4.1.5 Homing	18
4.1.5.1 Positioning homing	18
4.1.5.2 Proximity homing: negative direction	18
4.1.5.3 Proximity homing: positive direction	18
4.1.5.4 Proximity homing: negative direction + zero encoder	19
4.1.5.5 Proximity homing: positive direction + zero encoder	20

4.1.5.6	Torque homing: negative direction	20
4.1.5.7	Torque homing: positive direction	20
4.1.5.8	Torque homing: negative direction + zero encoder	21
4.1.5.9	Torque homing: positive direction + zero encoder	21
4.1.5.10	Homing offset	22
4.1.6	Other features	23
4.1.6.1	Profile software limits	23
4.1.6.2	Torque limit	23
4.2	Digital Inputs mode	23
Chapter 5 Profinet Protocol		25
5.1	Conventions	25
5.2	Startup parameters	26
5.3	Cyclic data	28
5.3.1	Control word	28
5.3.2	Mode operation	30
5.3.2.1	NONE	30
5.3.2.2	SPEED	30
5.3.2.3	POS_REL, POS_ABS	31
5.3.2.4	TORQUE	31
5.3.2.5	HOMING_0, ... HOMING_8	31
5.3.2.6	JOG	31
5.3.3	Output GPIO	31
5.3.4	Target position	32
5.3.5	Target speed	32
5.3.6	Target acceleration	32
5.3.7	Target deceleration	32
5.3.8	Target torque	32
5.3.9	Status word	32
5.3.10	Actual mode operation	33
5.3.11	Diagnostic word	33
5.3.12	Actual speed	35
5.3.13	Actual pos	35
5.3.14	Actual torque	35
5.3.15	Inputs	35
Chapter 6 Uvix		36
6.1	Introduction	36
6.2	General information	37
6.3	Status information	38
6.4	Details	39
6.4.1	Variables	39
6.4.2	Alarms	39

6.4.3	Commands	42
6.5	Configuration	43
6.5.1	Actuator	43
6.5.2	Motion	43
6.5.3	Communication	44
6.5.4	GPIO	44
6.6	Commissioning	45
6.6.1	DRVI states	45
6.6.2	Mode operation parameters	46
6.6.2.1	Homing	46
6.6.2.2	Speed Profile	47
6.6.2.3	Absolute position	47
6.6.2.4	Relative position	48
6.6.2.5	Torque profile	49
6.6.3	PID	49
6.7	Profinet configuration	50
6.8	UVIX USB Gateway	51
6.8.1	Main page	51
6.8.2	Firmware update	52

General recommendations

▲ Please comply with the recommendations for safe use described in this document.

- Some hazards can only be associated with the product after it has been installed on the machine/equipment. It is the responsibility of the end user to identify these hazards and reduce the risks associated with them.
- For information regarding the reliability of the components, contact Camozzi Automation.
- Before commissioning, carefully check that the DRVI has been correctly configured with regard to the data relating to the determination of the position and movement of the device. Failure to follow these instructions can result in injury or equipment damage.
- Avoid unprotected contact with hot surfaces. Be sure that the DRVI can dissipate the heat generated during normal operation to avoid equipment damage.
- Read the information in this document carefully before using the product.
- Keep this document in a safe place and close at hand for the whole of the product's life cycle.
- Pass this document on to any subsequent owner or user.
- The instructions in this manual must be observed in conjunction with the instructions and additional information concerning the product in this manual, available from the following reference links:
 - Website www.camozzi.com
 - Camozzi general catalogue
 - Technical assistance service
- Assembly and commissioning must be performed exclusively by qualified and authorised personnel on the basis of these instructions.
- It is the responsibility of the system/machine designer to ensure the correct selection of the most suitable component according to the intended application.
- Use of appropriate personal protective equipment is recommended to minimise the risk of physical injury.
- For all situations not contemplated in this manual and in situations in which there is the risk of potential damage to property, or injury to persons or animals, contact Camozzi for advice.
- Do not make unauthorised modifications to the product. In this case, any damage or injury to property, persons or animals will be the responsibility of the user.
- It is recommended to comply with all safety regulations that apply to the product.
- Never intervene on the machine/system until you have verified that all working conditions are safe.
- Before installation or maintenance, ensure that the required safety locks are active, and then disconnect the electrical mains (if necessary) and system pressure supply, discharging all residual compressed air from the circuit and deactivating residual energy stored in springs, condensers, recipients and gravity.
- After installation or maintenance, the electrical power supply (if necessary) must be reconnected, and the regular operation of the product must be checked. In the event of a malfunction, the product

1.1 Product storage and transport

must not be used.

- Avoid covering the equipment with paint or other substances that may reduce heat dissipation.

1.1 Product storage and transport

- Adopt all measures possible to avoid accidental damage to the product during transport, and when available use the original packaging.
- Observe the specified storage temperature range of $-20 \div 70$ °C.

1.2 Use

- Make sure that the distribution network voltage and all operating conditions are within the permissible values.
- The product may only be used in observance of the specifications provided; if these requirements are not met, the product may only be used upon authorisation by Camozzi.
- Follow the indications shown on the identification plate.

1.3 Limitations of use

- Do not exceed the technical specifications given in Paragraph 2 (General characteristics and conditions of use) and in the Camozzi general catalogue.
- Do not install the product in environments where the air itself may cause hazards.
- With the exception of specific intended uses, do not use the product in environments where direct contact with corrosive gases, chemicals, salt water, water or steam may occur.

1.4 Maintenance

- Incorrectly performed maintenance operations can compromise the good working order of the product and harm surrounding persons.
- Check conditions to prevent sudden release of parts, then suspend the power supply and allow residual stresses to discharge before taking action.
- Assess the possibility of having the product serviced by a technical service centre.
- Never disassemble a live unit.
- Isolate the product electrically before maintenance.
- Always remove accessories before maintenance.
- Always wear the correct personal protective equipment as envisaged by local authorities and in compliance with current legislation.
- In the event of maintenance, or replacement of worn parts, exclusively use the original Camozzi kits and ensure that operations are performed by specialised and authorised personnel. Otherwise product approval will be rendered invalid.

1.5 Ecological Information

1.5 Ecological Information

- At the end of the product's life cycle, it is recommended to separate the materials for recycling.
- Follow the waste disposal regulations in force in your country.
- The product and relative parts all comply with the ROHS and REACH standards.

Introduction

2.1 About this manual

This manual contains the technical description of the universal integrated servomotor, designed by Camozzi Automation S.p.A.

▲ Failure to observe the information contained in this manual can result in injury or equipment damage.

Please contact Camozzi Automation S.p.A. for technical assistance.

PRODUCT SPECIFICATIONS AND DATA ARE SUBJECT TO CHANGE WITHOUT NOTICE.

© Camozzi Automation S.p.A. All rights reserved.

2.2 Unit overview

The universal integrated servomotor unit is composed of a brushless or stepper motor and a FOC (Field Oriented Control) drive.

The unit is equipped with Profinet interface, that provides fieldbus communication capability with other devices, such as PLCs.

An absolute encoder allows to detect the rotor position of the motor, which is a fundamental quantity for the closed-loop control algorithms.

The power supply is divided in two sections: one for the logic stage and one for the power stage. In the following chapter are described the technical data of the drive.

Technical data

3.1 Environmental conditions

⚠ The drive installation must respect the environmental conditions specified in Table 3.1.

Table 3.1: Environmental conditions.

Condition	Value
Protection class	IP65, except motor shaft
Operating ambient temperature	-20 ... 50 °C
Storage ambient temperature	-20 ... 70 °C
Air humidity (non-condensing)	5 ... 95 %
Maximum altitude	1000 m

3.2 Electrical specifications

3.2.1 Power supply

The power supply section of the drive is divided into two parts:

- Logic (VL): provides supply to the logic stage, fieldbus interface and input-outputs.
- Main (VDC): provides supply to the power stage.

It's recommended to supply both Logic and Main power supplies by 2 different PELV (Protective Extra-Low Voltage) electronic circuits compliant to EN 60204-1

In Table 3.2 are shown the power supply operating ranges.

Table 3.2: Power supplies ranges.

Supply	Nominal value	Min/Max values
VL	24 V	24 V \pm 10%
VDC	48 V	60 V

The current absorption of the logic stage is <200mA (including auxiliary +24V output at maximum load).

⚠ During deceleration ramps the motor acts as a generator, returning a voltage on the VDC bus. The entity of such regeneration depends on the deceleration value and on the moment of inertia of the load attached to the shaft. If the voltage generated reaches the maximum VDC voltage, **the excess energy must be dissipated using an external braking system**, or changing the deceleration value otherwise the drive or the power supply could be damaged.

⚠ Install fuses for power supply cable in accordance with the electrical requirements of the equipment (be careful about inrush currents). A recommended fuse value is **T4A**.

It is also recommended to install a capacitor of 1000 uF, rated 100 V, after the output of the power supply.

3.2 Electrical specifications

⚠ The drive does not have an inrush current limitation, hence you must use the input of the power supply to turn the drive on and off. Never switch the output voltage of the power supply (hot plugging). In Figures 3.1 and 3.2 are shown the wiring examples for VDC and VL.

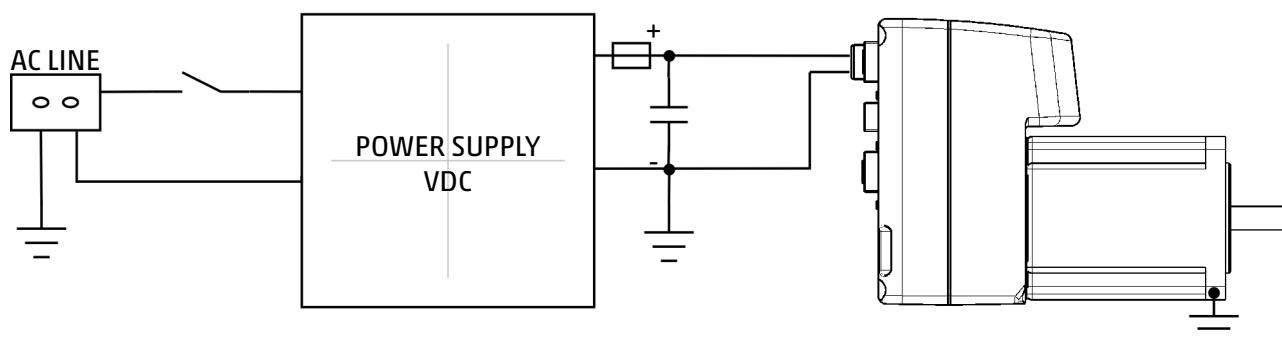

Figure 3.1: VDC wiring example.

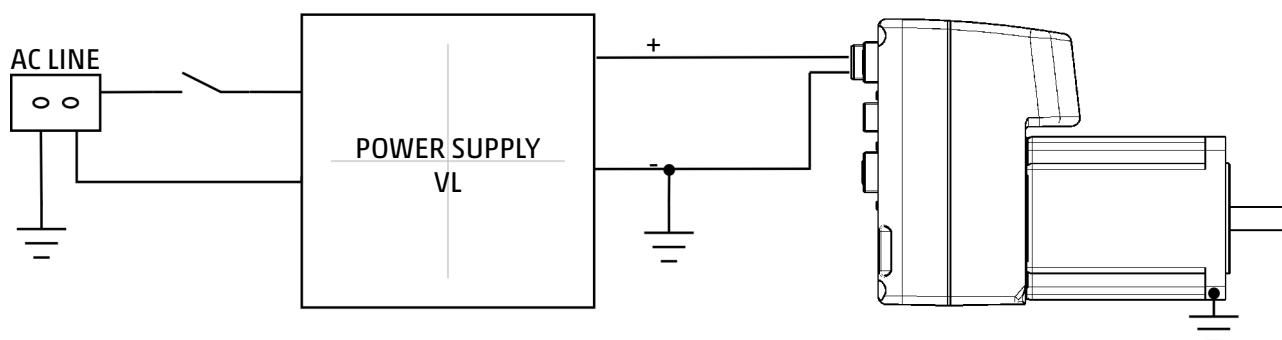

Figure 3.2: VL wiring example.

3.2.2 Wiring

The actual cable type, wire gauge, shield type, and filtering devices used are dependent on the environment, application, and system. However, we advise to use the following guidelines, when sizing the cables:

- The minimum section for the power supply cable should be AWG22 (0.75 mm²) when the motor uses the nominal current.
- For length less than 15 m, DC power supply cables can be used. Otherwise AC power supply cables should be used.
- To reduce EMC issues, use twisted and shielded cables.
- The shield should be connected to ground on the power supply side.

3.2.3 Encoder

The motor shaft position is measured using an absolute magnetic encoder.

3.3 Electrical connections

3.3 Electrical connections

In Figure 3.3 is shown the placement of the electrical connectors.



Figure 3.3: Connectors placement.

In Table 3.3 are shown the functionalities of the electrical connectors.

Table 3.3: Electrical connections.

Connection	Name	Functionality
①	PWS	Power supply
②	I/O	Inputs and outputs
③	STO	Safe Torque Off (when present) ⚠ NOT CERTIFIED
④	P1 = PORT 1	Profinet Fieldbus Interface
⑤	P2 = PORT 2	Profinet Fieldbus Interface
⑥	-	USB (Micro-B)

NOTE: All connectors are screw type. During the wiring phase, be careful not to tighten the connectors too forcefully. The use of tools to tighten the connectors is absolutely not recommended.

3.3 Electrical connections

3.3.1 1 - Power supply

The power supply connector is a 5-poles M12 (male) A-coded. In Table 3.4 is represented the pinout of the power supply connector.

Table 3.4: 1 - Power supply connector pinout.

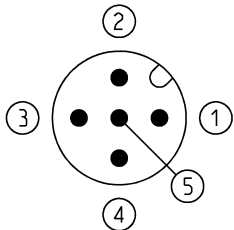
PIN	Signal	Function	Symbol
1, 5	VDC	Main power supply	
2	GND	Main power ground	
3	VL	Logic power supply	
4	GND	Main power ground	

Camozzi connector receptacle:

- CS-LF05HC, straight connector M12 5-poles male.
- CS-LF04HB, straight connector M12 5-poles male (Pin 5 is not connected).
- CS-LF05HB-D200, cable with straight M12 5-poles male connector, length 1m.
- CS-LF05HB-D500, cable with straight M12 5-poles male connector, length 5m.

⚠ The pins with GND indication are internally connected.

3.3.2 2 - GPIO

The GPIO connector is a 12-poles M12 (female) A-coded. In Table 3.5 is described the functionality of each pin and is represented the pinout of the GPIO connector.

3.3 Electrical connections

Table 3.5: 2 - GPIO connector pinout.

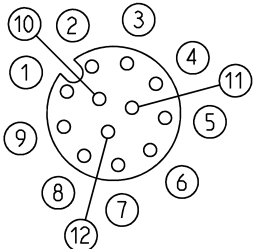
PIN	Signal	Function	Symbol
1, 2	IN1	Digital input 1 (compliant to IEC61131-2)	
3, 4	IN2	Digital input 2 (compliant to IEC61131-2)	
5, 6	OUT	Solid state relay output (PTC resettable fuse, 0.5 A hold current)	
7, 8	EXT PROXY	Digital input (24 V) for external proximity	
9, 10	PROXY HOMING	Digital input (24 V) for homing proximity	
11	GND	Digital ground	
12	+24V	Auxiliary +24 V output, max 130 mA	

NOTE: the EXT PROXY is usually used to connect the optional limit switch sensor, whilst the PROXY HOMING is used for the homing zero position

NOTE: IN1 and IN2 are general purpose inputs, typically they could be used for the jog clockwise and counter-clockwise function (see Chapter 4.2)

3.3 Electrical connections

Camozzi connector receptacle:

- CS-LM12HC, circular connector field attachable M12 12-poles (male) A-coded.
- CS-LO12HC-0025, straight connector M12 12-poles (male) and two M8 female (proximity), length 20 cm.
- CS-LM12HC-D500, straight connector M12 12-poles (male), length 5m.

Digital inputs are bidirectional: in Figure 3.4 is represented the input hardware stage.

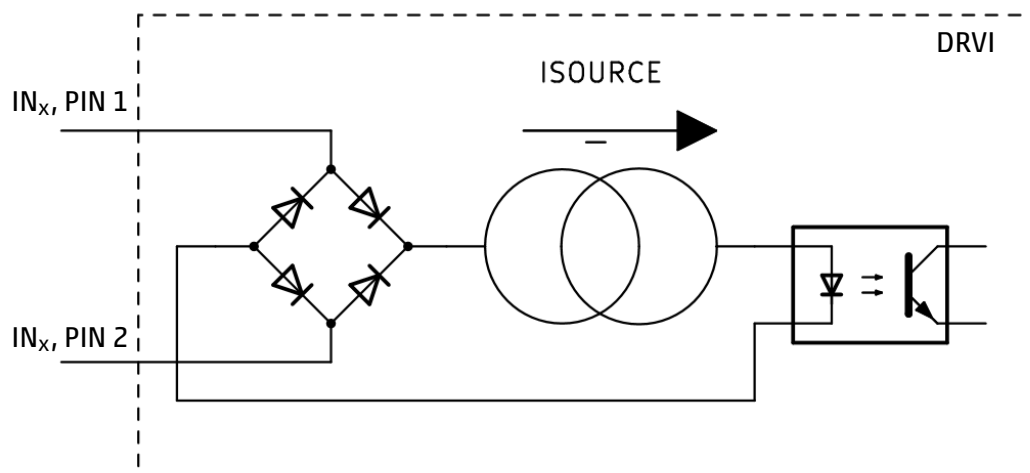

Figure 3.4: GPIO IN stage.

In Figure 3.5 is represented the output hardware stage.

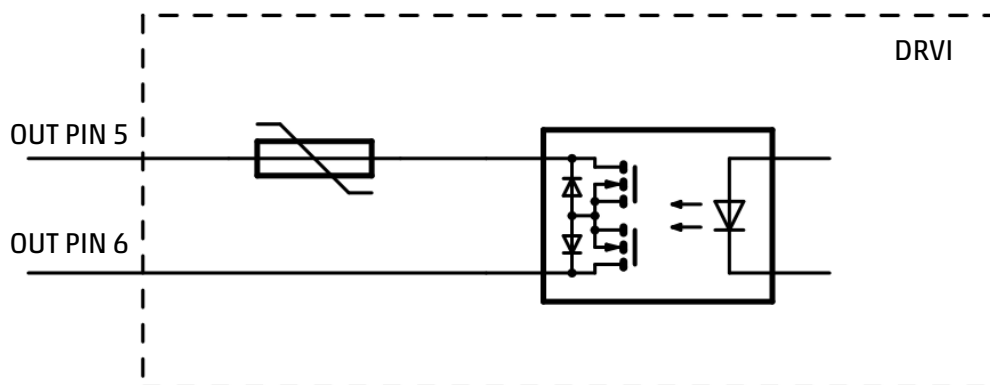

Figure 3.5: GPIO OUT stage.

3.3.3 3 - STO (NOT CERTIFIED)

⚠ STO (SAFE TORQUE OFF) FEATURE IS NOT CERTIFIED.

The STO connector (when present) is 4-poles M8 (female) A-coded. In Table 3.6 is shown the connector pinout and is displayed the STO connector. To allow the motor movement, IN1 and IN2 must be connected to +24 V, while COM1 and COM2 to GND. If IN1 or IN2 voltages are missing, the STO intervenes disconnecting the motor phases.

Camozzi connector receptacle:

- CS-DM04HB, circular connector field attachable M8 4-poles (male) A-coded.

3.3 Electrical connections

- CS-LM04HB-D500, straight connector M8 4-poles (male), length 5m.

Table 3.6: 3 - STO connector pinout.

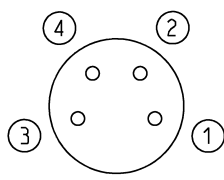
PIN	Signal	Function	Symbol
1	IN1	STO1 signal	
2	COM1	Common signal of STO1	
3	IN2	STO2 signal	
4	COM2	Common signal of STO2	

3.3.4 4, 5 - Ethernet fieldbus interface

The Fieldbus connectors are 4-poles M12 (female) D-coded. In Table 3.7 are shown the connector pinout and the fieldbus connector (PORT 1, PORT 2).

Table 3.7: 4, 5 - Fieldbus connector pinout.

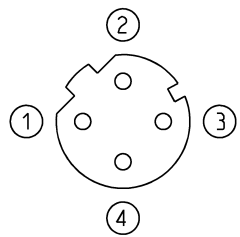
PIN	Signal	Function	Symbol
1	TXP	Transmission data (+)	
2	RXP	Reception data (+)	
3	TXN	Transmission data (-)	
4	RXN	Reception data (-)	

3.4 LED indicators

Camozzi Ethernet fieldbus cables:

- CS-SB04HB-D100, co-molded cable with straight M12D 4-poles male connector, length 1m.
- CS-SB04HB-D500, co-molded cable with straight M12D 4-poles male connector, length 5m.
- CS-SB04HB-DA00, co-molded cable with straight M12D 4-poles male connector, length 10m.
- CS-SB04HB-DD00, co-molded cable with straight M12D 4-poles male connector, length 15m.
- CS-SB04HB-DG00, co-molded cable with straight M12D 4-poles male connector, length 20m.
- CS-SB04HB-DJ00, co-molded cable with straight M12D 4-poles male connector, length 25m.
- CS-SB04HB-DM00, co-molded cable with straight M12D 4-poles male connector, length 30m.
- CS-SB04HB-DS00, co-molded cable with straight M12D 4-poles male connector, length 40m.
- CS-SB04HB-DY00, co-molded cable with straight M12D 4-poles male connector, length 50m.
- CS-SE04HB-F050, molded cable with straight RJ45 male – M12D 4 pin female connector (adapter and panel mount) to connect to the controller.

3.3.5 6 - USB interface

The USB port allows the drive configuration using the UVIX interface. The USB connector is a Micro USB type B.

Camozzi connector receptacle:

- G11W-G12W-2, standard cable with micro-USB connector length 2m.

3.3.6 Earth connection

⚠ It is mandatory to connect the motor flange to earth (\perp). The GND must be connected to the earth, using a common central point, near to the power supply.

3.4 LED indicators



















The integrated drive provides visual information using LED indicators. Their functionality is shown in Table 3.8, and their detailed description is given in Table 3.9.

Table 3.8: LED indicators functionality.

Name	Color	Function	Indicator
L/A1	Green / yellow (bicolor)	Link / activity LED for Ethernet channel 1	
L/A0	Green / yellow (bicolor)	Link / activity LED for Ethernet channel 0	
BF	Red	Bus failure	
SF	Red	System failure	
SYS	Red / green (bicolor)	Drive system LED	

3.4 LED indicators

Table 3.9: LED indicators description.

Name	Color	State	Description
L/A1		OFF	No link has been established on Ethernet Port 0
		ON	Link has been established on Ethernet Port 1
		BLINK	Data is received or transmitted on Ethernet Port 1
L/A0		OFF	No link has been established on Ethernet Port 0
		ON	Link has been established on Ethernet Port 0
		BLINK	Data is received or transmitted on Ethernet Port 0
BF		OFF	Profinet active communication link
		ON	No Profinet link status available
SF		OFF	No Profinet diagnostic
		ON	Profinet diagnostic exists
		BLINK	Initialization of DCP service
SYS		BLINK	Profinet link status ok / network connection interrupted or defective
		1 BLINK	Servo OFF
		2 BLINK	Servo ON
		1 BLINK	VL / VDC UVLO or OVLO error
		2 BLINK	Over temperature or I ² T error
		3 BLINK	STO error
		4 BLINK	Homing error / internal error

Operation Modes

This Chapter describes the possible operation modes of the drive that could be fieldbus modes or digital inputs mode

4.1 Fieldbus Modes

4.1.1 Speed

This drive mode operation requires a specific target speed, acceleration and deceleration: once the velocity target is set, the motor accelerates until the target speed is reached and then maintains the required velocity until a new request is made. The speed profile executed is trapezoidal.

In Figure 4.1 is shown an example of speed profile with the following parameters:

- Target acceleration = 60 RPM / s
- Target deceleration = 60 RPM / s
- Initial speed = 0 RPM
- Target speed = 60 RPM (target given at $t = 0$ s)
- Target speed = 0 RPM (target given at $t = 2$ s)

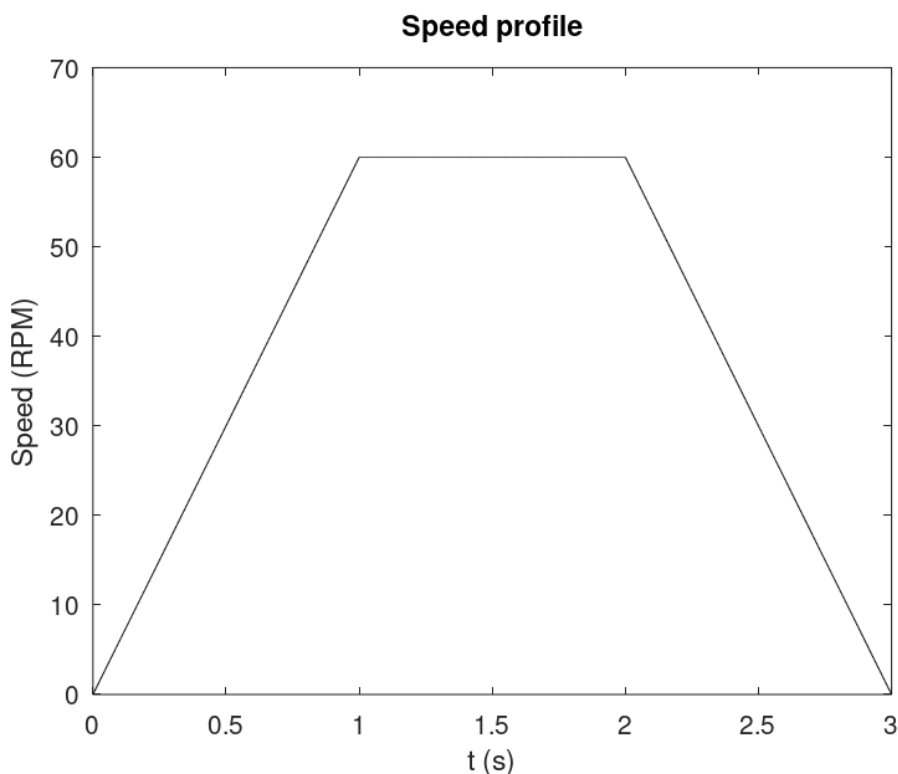

Figure 4.1: Speed profile example.

4.1 Fieldbus Modes

4.1.2 Positioning

This drive operation modes requires a specific target position, velocity, acceleration and deceleration, to compute the motion profile used to reach the target position. The position profile executed is of "S" type and the speed profile is trapezoidal.

In Figure 4.2 is shown an example of positioning profile with the following parameters:

- Initial position = 0 °
- Target position = 720 ° (target given at t = 0 s)
- Initial speed = 0 RPM
- Target speed = 60 RPM
- Target acceleration = 60 RPM / s
- Target deceleration = 60 RPM / s

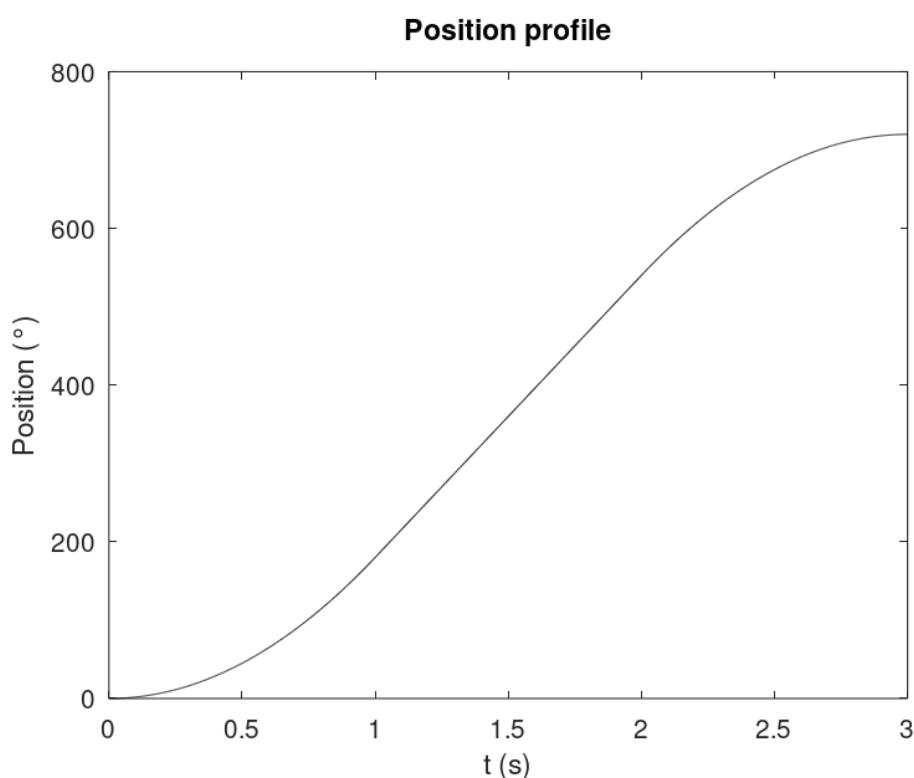

Figure 4.2: Positioning profile example.

In Figure 4.3 are represented both the position (continuous line) and speed (dashed line) profiles per unit (position / 360 ° and speed / 60 RPM).

4.1 Fieldbus Modes

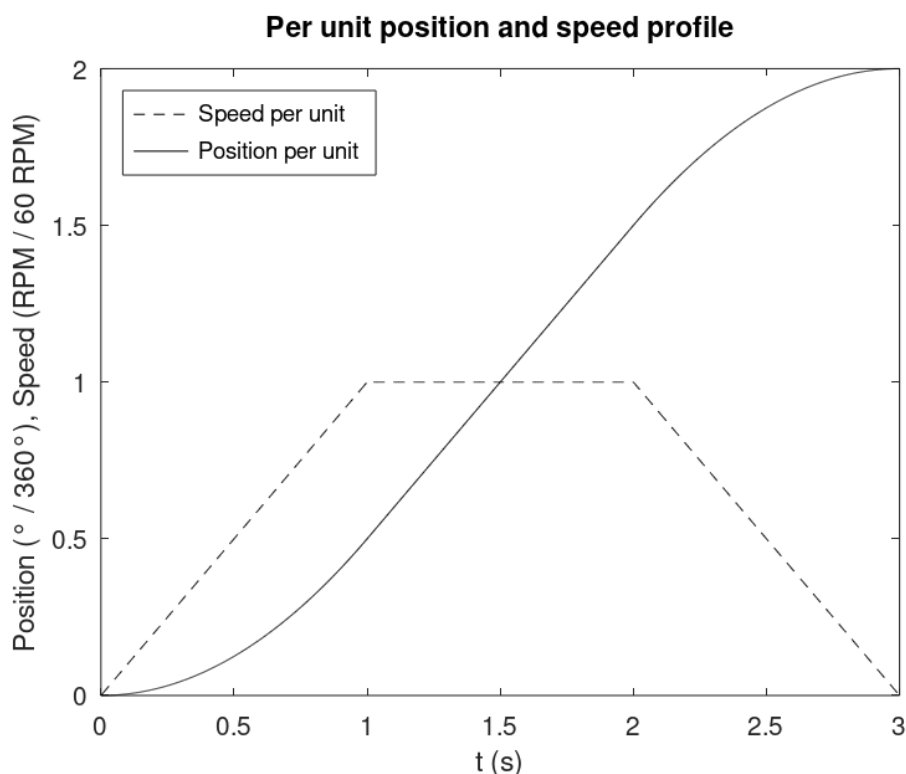

Figure 4.3: Positioning and speed profile example.

4.1.2.1 Relative Positioning

In relative positioning profile the target is computed as offset with respect to the current position. For example, if the actual absolute rotor position is 360° and the requested relative positioning target is 360° , the motor will rotate to reach the absolute position of 720° .

4.1.2.2 Absolute Positioning

In absolute positioning profile the target is absolute. For example, if the absolute rotor position is 360° and an absolute positioning target of 360° is given, the motor will not move.

4.1.3 Torque

This drive operation mode requires a specific target (current) torque, positive torque slope and negative torque slope. Target torque is expressed in mA and torque slopes in mA / s.

In Figure 4.4 is shown an example of torque profile with the following parameters:

- Positive torque slope = 1000 mA / s
- Negative torque slope = 1000 mA / s
- Initial torque = 0 mA
- Target torque = 1000 mA (target given at t = 0 s)
- Target torque = 0 mA (target given at t = 2 s)

4.1 Fieldbus Modes

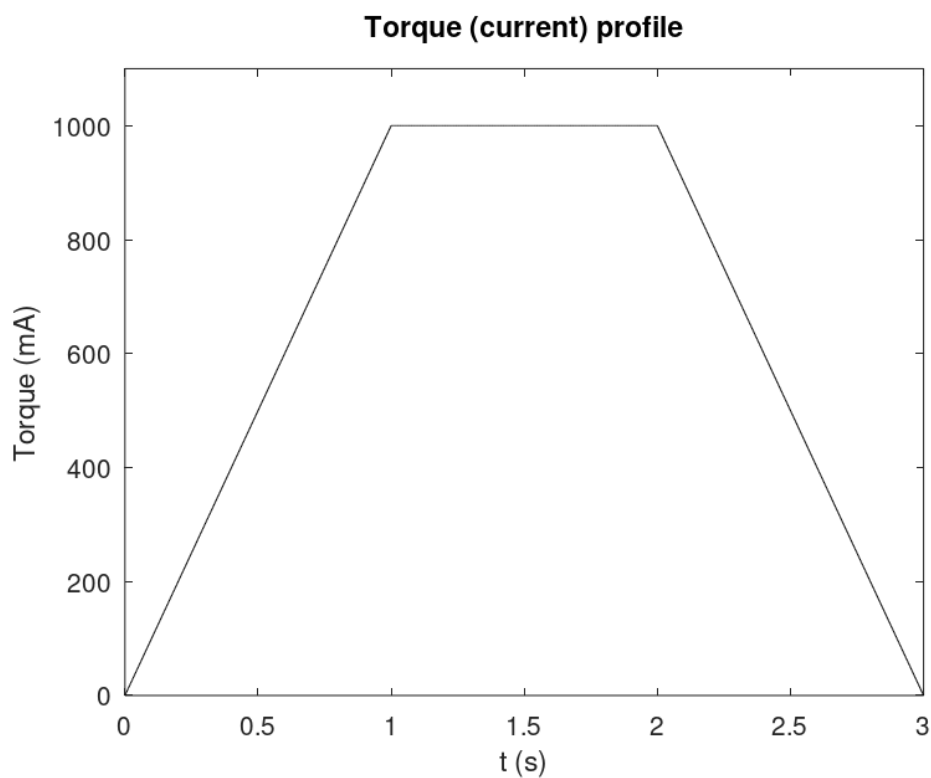

Figure 4.4: Torque (current) profile example.

4.1.4 Jog

The JOG mode allows to control the drive in speed mode using two bits of the controlword

4.1 Fieldbus Modes

4.1.5 Homing

In this Section are described the possible homing procedures. It is mandatory to execute homing before using positioning operations. Homing parameters can be configured using UVIX interface (refer to Section 6.6.2.1). If proximity is used it must be connected to the PROXY INPUT (refer to Section 3.3.2).

4.1.5.1 Positioning homing

Homing at the current position (refer to Figure 4.5). This mode does not require an external proximity

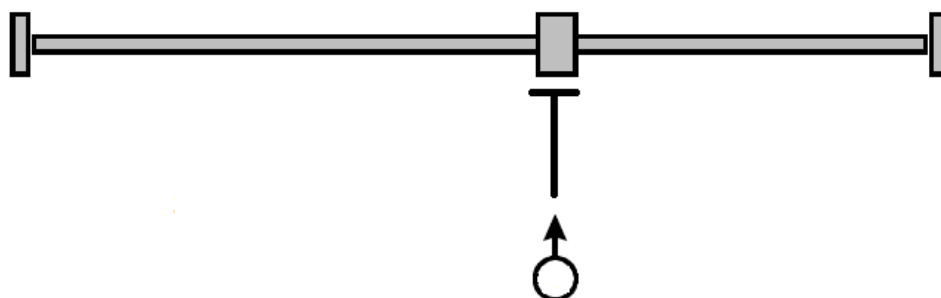

Figure 4.5: Positioning homing.

and the homing procedure consists of setting the current position (without moving the motor) as zero position.

4.1.5.2 Proximity homing: negative direction

Proximity search in negative direction (refer to Figure 4.6).

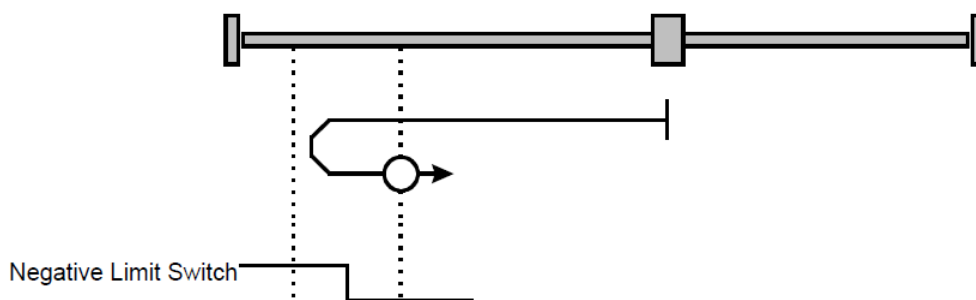

Figure 4.6: Proximity homing: negative direction.

In this mode, the motor searches for the zero proximity in the negative direction of the movement, with the velocity set to "homing speed search". As soon as the proximity is detected, the motor stops and exits the proximity, in the opposite direction, with the velocity set to "homing speed out". If the proximity is already detected on the start of the homing procedure, the motion will start with the "homing speed out" phase. If the proximity is surpassed because of the inadequate speed / deceleration combination, the homing procedure is interrupted and a homing error is returned.

4.1.5.3 Proximity homing: positive direction

Proximity search in positive direction (refer to Figure 4.7).

4.1 Fieldbus Modes

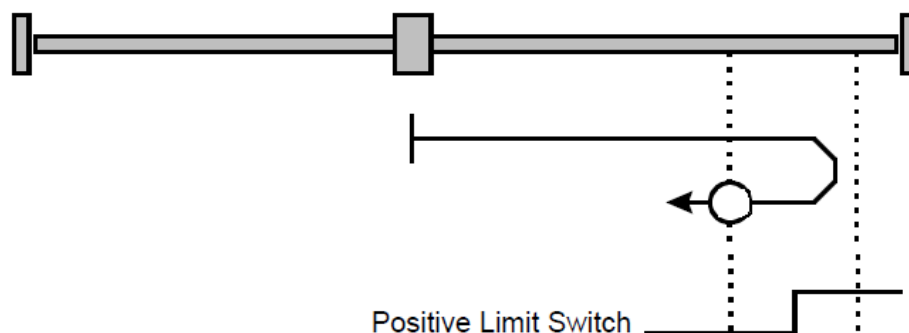

Figure 4.7: Proximity homing: positive direction.

In this mode, the motor searches for the zero proximity in the positive direction of the movement, with the velocity set to "homing speed search". As soon as the proximity is detected, the motor stops and exits the proximity, in the opposite direction, with the velocity set to "homing speed out". If the proximity is already detected on the start of the homing procedure, the motion will start with the "homing speed out" phase. If the proximity is surpassed because of the inadequate speed / deceleration combination, the homing procedure is interrupted and a homing error is returned.

4.1.5.4 Proximity homing: negative direction + zero encoder

Proximity search in negative direction and then search for the index pulse (zero of the encoder) in the positive direction (refer to Figure 4.8).

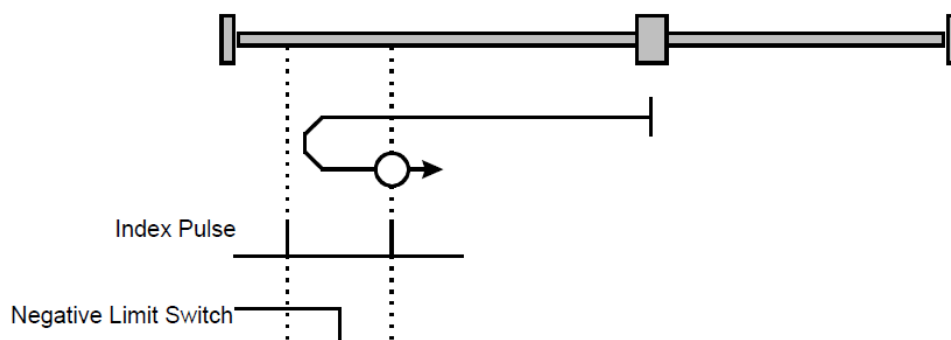

Figure 4.8: Proximity homing: negative direction + zero encoder.

In this mode, the motor searches for the zero proximity in the negative direction of the movement, with the velocity set to "homing speed search". As soon as the proximity is detected, the motor stops and exits the proximity, in the opposite direction, with the velocity set to "homing speed out", until it finds the zero encoder. If the proximity is already detected on the start of the homing procedure, the motion will start with the "homing speed out" phase. If the proximity is surpassed because of the inadequate speed / deceleration combination, the homing procedure is interrupted and a homing error is returned.

4.1 Fieldbus Modes

4.1.5.5 Proximity homing: positive direction + zero encoder

Proximity search in positive direction and then search for the index pulse (zero of the encoder) in the negative direction (refer to Figure 4.9).

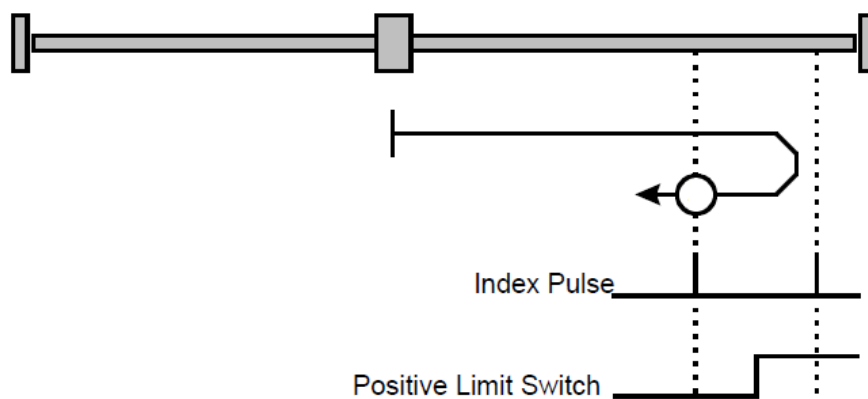

Figure 4.9: Proximity homing: positive direction + zero encoder.

In this mode, the motor searches for the zero proximity in the positive direction of the movement, with the velocity set to "homing speed search". As soon as the proximity is detected, the motor stops and exits the proximity, in the opposite direction, with the velocity set to "homing speed out", until it finds the zero encoder. If the proximity is already detected on the start of the homing procedure, the motion will start with the "homing speed out" phase. If the proximity is surpassed because of the inadequate speed / deceleration combination, the homing procedure is interrupted and a homing error is returned.

4.1.5.6 Torque homing: negative direction

Homing torque in negative direction (refer to Figure 4.10). In this mode the motor rotates in the neg-

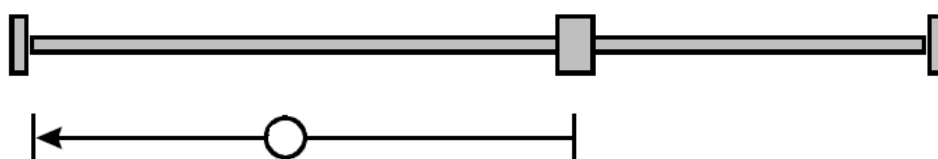

Figure 4.10: Torque homing: negative direction.

ative direction of the movement, with the velocity set to "homing speed search", until it stops against the end of the line and the I^2T reaches the homing set value.

4.1.5.7 Torque homing: positive direction

Homing torque in positive direction (refer to Figure 4.11). In this mode the motor rotates in the positive direction of the movement, with the velocity set to "homing speed search", until it stops against the end of the line and the I^2T reaches the homing set value.

4.1 Fieldbus Modes

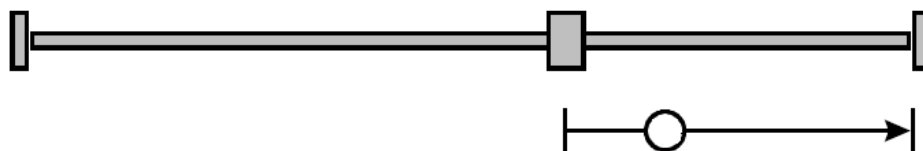

Figure 4.11: Torque homing: positive direction.

4.1.5.8 Torque homing: negative direction + zero encoder

Homing torque in negative direction and then search for the index pulse (zero of the encoder) in the positive direction (refer to Figure 4.12).

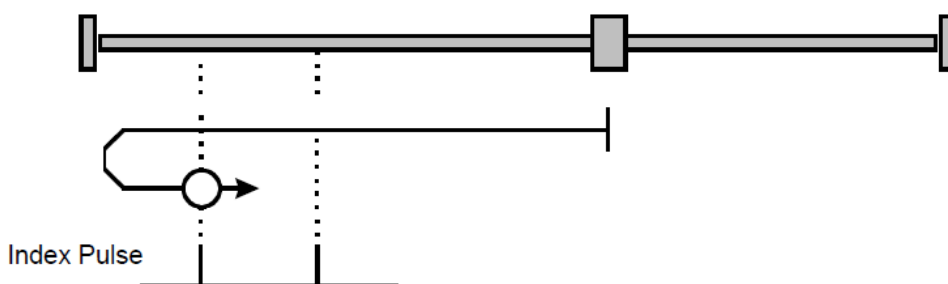

Figure 4.12: Torque homing: negative direction + zero encoder.

In this mode the motor rotates in the negative direction of the movement, with the velocity set to "homing speed search", until it stops against the end of the line and the I^2T reaches the homing set value. At this point the motor rotates in the opposite direction, with the velocity set to "homing speed out", until it finds the zero encoder.

4.1.5.9 Torque homing: positive direction + zero encoder

Homing torque in positive direction and then search for the index pulse (zero of the encoder) in the negative direction (refer to Figure 4.13).

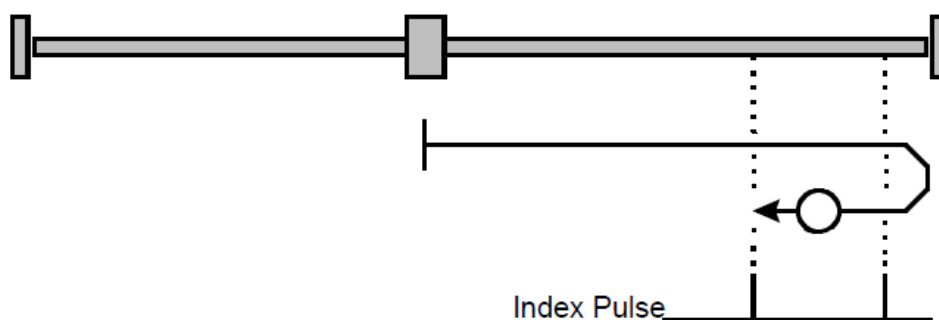

Figure 4.13: Torque homing: positive direction + zero encoder.

In this mode the motor rotates in the positive direction of the movement, with the velocity set to "homing speed search", until it stops against the end of the line and the I^2T reaches the homing set value. At this point the motor rotates in the opposite direction, with the velocity set to "homing speed out", until it finds the zero encoder.

4.1 Fieldbus Modes

4.1.5.10 Homing offset

The Homing offset indicates the configured difference between the **zero position** for the application and the machine **home position** (found during homing). During homing the motor moves to search the home position: it is possible to change the zero position, that by default is set at the same value of the home position, by adding an offset to the home position. This value could be positive or negative and all subsequent absolute movements shall be taken relative to this new zero position.

4.2 Digital Inputs mode

4.1.6 Other features

In this chapter are described other features that can be used in combination with the various modes of operation.

4.1.6.1 Profile software limits

Profile software limits can be set to restrict the motion parameters (positions, speed, acceleration and deceleration) to a desired value.

Such limits can be configured using the UVIX interface (refer to Section 6.5.1) and are valid for all the configurations different from "only motor" and for all the modes of operation.

Software limits take effect only after homing execution and if the corresponding "software limits enable" in the protocol is set (refer to Chapter 5 controlword bit6). In case a position software limit error is triggered (for example the servo has been set momentary OFF and the motor has been moved beyond the software position limit or the EXT PROXY INPUT signal has been caught), the drive, if it was moving, stops itself using the QUICK_STOP that is the deceleration parameter set in UVIX (refer to Section 6.5.2) and it goes into error state and the correspondent error is raised on the fieldbus. In such situation, to bring back the motor into the allowed position range, the error must be reset first. Then, it is allowed to move the motor using any of the mode of operations (even if it is still out of the allowed range, because the software limit check will be momentary disabled). The error check on positioning will be restored automatically after the first movement completion (target position for positioning control or zero speed for speed control), provided that the "software limit enable" is still set.

Regarding target position, target speed, acceleration and deceleration values, if their target values exceed the limit value, the set is inhibited, that is, the parameter is not applied (the previous valid parameter remains valid) and the "command refused" warning is raised.

Profile position hardware limit: The position limit feature of Section 4.1.6.1 can be achieved also using a proximity sensor connected to the EXT PROXY INPUT (refer to Section 3.3.2). As soon as the EXT PROXY INPUT goes to HIGH state, the drive behaves as described in Section 4.1.6.1. Note that the hardware limit takes effect only if the "software limits enable" in the protocol is set.

4.1.6.2 Torque limit

Torque limitation is a feature that allows to limit the torque (current) supplied by the motor. This feature can be enabled and disabled using the provided "torque limit enable" in the protocol (refer to Chapter 5, controlword bit7).) and it takes effect for all the modes of operation. The current limit value is configured using the fieldbus interface and it can be changed in real-time using the Target torque parameter (refer to Chapter 5).

4.2 Digital Inputs mode

The drive can be configured to be moved only using digital inputs signals. This functionality excludes the fieldbus and the motor can be moved in speed mode using only inputs IN1 and IN2 to decide the direction of the movement. PROXY EXT and PROXY INPUT can be used as limits of the range of movement

4.2 Digital Inputs mode

(refer to Section 3.3.2). The UVIX application must be used to set and enable the Digital Inputs mode and to set and store in nonvolatile memory the specific parameters of this mode. After these operations, the drive must be rebooted (turn OFF and ON the VL logic power supply) to apply the configuration. In Table 4.1 is shown the truth table of the Digital Inputs mode. Note that the option "rotation direction", settable via UVIX, is ignored when the drive is in Digital Inputs mode.

Table 4.1: Digital Inputs truth table.

IN1	IN2	Effect
LOW	LOW	Stop (zero speed)
HIGH	LOW	Clockwise rotation
LOW	HIGH	Counter-clockwise rotation
HIGH	HIGH	Invalid command (previous state persists)

When the user changes the IN1 or IN2 logical status to value one, the drive begins to move until:

- it reaches one of the PROXIES and in this case it automatically stops itself or
- the user set IN1 and IN2 to the zero logical value.
- the drive has some problems and it stops in error: in this case the only way to know which type of error, it is to check the number of flashes of the error LED; if the drive goes in error, automatically servo will be OFF.

Profinet Protocol

This Chapter describes how to configure and control the drive with a Profinet PLC.

5.1 Conventions

In this Section is given a description about the conventions used in this manual.

The data types used are shown in Table 5.1:

Table 5.1: Data types.

Name	Type
DINT	32 bit signed
DWORD	32 bit unsigned
INT	16 bit signed
WORD	16 bit unsigned

In Table 5.2 are shown the units of measurement used by the drive.

Table 5.2: Units of measurement.

Quantity	Unit
Position	Degrees · 100 (*) mm · 100 (**)
Speed	RPM · 100 (*) mm / s · 100 (**)
Acceleration	RPM / s (*) mm / s ² (**)
Deceleration	mA / s (***) RPM / s (*) mm / s ² (**) mA / s (***)
Torque (current)	mA

(*) Used when the drive is configured as "only motor".

(**) Used in all other configurations different from "only motor".

(***) Used in torque (current) control.

A positive position or a positive speed target cause the motor shaft to rotate in a clockwise direction, when the motor shaft is viewed from the front. Example: a position target of 36000, when the drive is configured as "only motor", corresponds to one turn of the shaft in a clockwise direction.

5.2 Startup parameters

In Table 5.3 are listed the parameters that are sent by the PLC to the drive at the startup.

If the option "Stored Parameters" of "System Start" parameter is selected, the drive will load the startup parameters stored in internal memory, instead if the option "External" is used, the drive will use the parameters sent by the PLC. All the parameters are stored in non volatile memory upon variation.

The "Endianness" parameter allows to set the endianness of the communication between the PLC and the drive.

The "Diagnosis" parameter allows to enable or disable the diagnostic errors. The "PID Selection" parameter provides five different presets for speed and position PID controllers, that can be selected according to the specific application. For particular needs, the "PID Custom" configuration can be used and in this case, PID speed and position can be tuned using "PID Position" and "PID Speed" parameters. It is suggested to use the "Default" PID configuration when the drive has little or no load attached. Use instead the other presets, according to the entity of the load attached to the shaft.

The "Profile Check" parameter allows to control if the target speed (when in speed control) or the target position and speed (when in position control) are actually reached by the motor, during the motion execution. The "Profile Timeout" parameter, expressed in milliseconds, is the time after which the error is returned, in case target position or target speed are not reached.

Target scale factor "Numerator" and "Denominator" allow to apply a scaling to the profile parameters (i.e.: final targets are multiplied by "Numerator" and divided by "Denominator").

The "Motion direction" parameter allows to set the motor movement positive direction, clockwise or counterclockwise.

The "Actuator screw pitch" defines the value in mm that the axis moves for each motor revolution.

The "Homing parameters" allows to set the Homing speeds (fast and slow) and the acceleration (regarding it, in case of using the startup parameters by PLC, the value is unique for all homing accelerations In and Out, whilst using UVIX is possible to set 4 different values).

5.2 Startup parameters

Table 5.3: Startup parameters.

Parameter	Description	Options
Endianness	Data format used	Little Endian (INTEL) Big Endian (MOTOROLA)
System Start	Startup parameters to use	Stored Parameters External
Diagnosis	Errors diagnostic	Enabled Disabled
PID Selection		Default Low load Medium load High load Custom
PID position	Valid for Custom PID selection	KP Position KI Position
PID speed	Valid for Custom PID selection	KP Speed KI Speed
Profile	Control target speed / position reached	Check Timeout (ms)
Target scale factor	Scale factor applied to speed / position / acc / dec	Numerator Denominator
Motion direction	Set the motor rotation direction	clockwise counterclockwise
Actuator screw pitch		mm/motor revolution
Torque homing threshold	Torque limit during the homings	% of the I ² T limit value
Actuator type		Only motor Custom Actuator
Homing parameters		Fast speed Slow speed acceleration/deceleration

5.3 Cyclic data

5.3 Cyclic data

In Table 5.4 and Table 5.5 are shown the cyclic data exchanged between the drive and the PLC.

Table 5.4: Data input (from PLC to drive).

Offset	Variables	Type	Description
0	CTRL_WORD	WORD	Control word
2	MODE_OPERATION	WORD	Mode operation
4	OUTPUT_GPIO	WORD	Output GPIO
6	TARGET_POS	DINT	Target position
10	TARGET_SPEED	DINT	Target speed
14	TARGET_ACC	WORD	Target acceleration
16	TARGET_DEC	WORD	Target deceleration
18	TARGET_TORQUE	INT	Target torque

Table 5.5: Data output (from drive to PLC).

Offset	Variables	Type	Description
0	STATUS_WORD	WORD	Status word
2	ACTUAL_MODE_OPERATION	WORD	Mode operation state
4	DIAGNOSTIC_WORD	DWORD	Diagnostic word
8	ACTUAL_SPEED	DINT	Actual speed
12	ACTUAL_POS	DINT	Actual position
16	ACTUAL_TORQUE	INT	Actual torque (current)
18	INPUTS	WORD	Inputs GPIOs status

5.3.1 Control word

The drive states are changed by means of the CONTROL_WORD variable. Following is given a description of its bitfield:

5.3 Cyclic data

Table 5.6: Control word.

Bit	Value	State	Description
0	0	SERVO_OFF	Control disabled (idle)
	1	SERVO_ON	Control enabled
1	0		Inhibit target changes
	1	START_MOV	Allow target changes in SPEED and TORQUE mode
	\uparrow	START_MOV	Start movement for POS_REL and POS_ABS Enable a change in MODE_OPERATION
2	\uparrow	HALT	Motion stop
3	\uparrow	QUICK_STOP	Motion quick stop
4	\uparrow	RES_ERR	Reset errors and warnings
5	-	-	(not used)
6	0	SWLIM	Software limits disabled
	1		Software limits enabled
7	0	TORQUE_LIM	Torque limitation disabled
	1		Torque limitation enabled
8	0	JOG_LEFT	JOG left disabled
	1		JOG left enabled
9	0	JOG_RIGHT	JOG right disabled
	1		JOG right enabled

The \uparrow symbol means that the action is taken upon the transition from 0 to 1 of the respective bit. The transition from 0 to 1 of the START_MOV bit has the effect of:

- Enable the movement and load the profile parameters for POS_REL and POS_ABS mode operations.
- Applies a change of MODE_OPERATION.

In SPEED and TORQUE operation mode, the START_MOV bit has the effect of global enable. For example, if START_MOV bit is set, a change of target (e.g.: TARGET_SPEED) has immediate effect. Instead, if the START_MOV bit is reset, parameters changes are ignored. Note that in POS_REL and POS_ABS operation mode, to start the movement and load the profile parameters, the START_MOV bit have to make a transition from 0 to 1.

The HALT command causes the actual movement to stop, using as deceleration value the TARGET_DEC value taken from the data input.

The QUICK_STOP command causes the actual movement to stop, using as deceleration value the correspondent parameter configured with UVIX (see Paragraph 6.5.2).

The SWLIM bit enables or disables the actuator software limits configured with UVIX (see Paragraph 6.5.1).

The TORQUE_LIM bit enables or disables the torque (current) limitation feature (see Paragraph 4.1.6.2).

The limit current value is the one taken from the cyclic data variable TARGET_TORQUE. Hence, for example, if TARGET_TORQUE = 1000 is set, the drive current will be limited to 1 Ampere, in all the modes of operation.

The JOG_LEFT and JOG_RIGHT bits allow to control the JOG mode according to the truth Table 5.8. Notice that these bits work only when the drive is in JOG mode operation.

5.3 Cyclic data

5.3.2 Mode operation

The drive modes of operation are changed by means of the MODE_OPERATION variable. To execute any of the mode operation states, the SERVO_ON bit must be set first, while mode operation value is NONE. In Table 5.7 is given the correspondence between the MODE_OPERATION value and the modes of operation described in Chapter 4.

Table 5.7: Modes of operation.

Value	Label	Mode of operation
0	NONE	
1	SPEED	Speed
2	POS_REL	Positioning relative
3	POS_ABS	Positioning absolute
4	TORQUE	Torque
5	HOMING_0	Positioning homing
6	HOMING_1	Proximity homing: negative direction
7	HOMING_2	Proximity homing: positive direction
8	HOMING_3	Proximity homing: negative direction + zero encoder
9	HOMING_4	Proximity homing: positive direction + zero encoder
10	HOMING_5	Torque homing: negative direction
11	HOMING_6	Torque homing: positive direction
12	HOMING_7	Torque homing: negative direction + zero encoder
13	HOMING_8	Torque homing: positive direction + zero encoder
14	JOG	Jog

A mode operation change takes effect immediately, provided that the operation is allowed, but the new target execution takes effect on the transition from 0 to 1 of the START_MOV bit. To switch from different mode operations, the drive must first be stop (zero speed for speed or torque control and stop position in positioning control), otherwise the change of command will be discarded and the "command refused" bit of the warning word will be set.

5.3.2.1 NONE

This is the mode operation present at the first drive startup (servo off).

5.3.2.2 SPEED

In SPEED operation it is mandatory first to set a TARGET_ACC and a TARGET_DEC value different from zero, before setting the START_MOV bit, otherwise the "command refused" warning is returned. To enable speed operation, the START_MOV bit of the control word must be set to "1". Consecutive speed targets can be given, also interrupting an executing target, provided that the START_MOV bit is high.

5.3 Cyclic data

5.3.2.3 POS_REL, POS_ABS

In POS_REL or POS_ABS operations it is mandatory first to set a SPEED, TARGET_ACC and a TARGET_DEC value, different from zero, before setting the START_MOV bit, otherwise the "command refused" warning is returned. To enable this operation, the START_MOV bit of the control word must make a transition from "0" to "1". It is possible to execute a new target, or change the current target during a movement, as long as a new rising edge of the start bit is provided.

5.3.2.4 TORQUE

In TORQUE operation it is mandatory first to set a TARGET_ACC and a TARGET_DEC value different from zero, before setting the START_MOV bit, otherwise the "command refused" warning is returned. To enable speed operation, the START_MOV bit of the control word must be set to "1". Consecutive torque (current) targets can be given, also interrupting an executing target, provided that the START_MOV bit is high.

5.3.2.5 HOMING_0, ... HOMING_8

Homing parameters such as speeds, accelerations decelerations and so on, can be set and stored in the drive memory using the UVIX interface (refer to Section 6.6.2.1), although the default stored parameters should be fine for most of the user applications. If needed, an offset can be added to the homing position: in such case, after homing execution, the drive will display such value as current position, instead of zero. In torque homing the drive will rotate at constant speed, until it stops against an obstacle. The homing position will be detected when the I²T value will reach the established set-point. To enable HOMING operation (i.e.: starting homing execution), the start bit of the control word, must make a transition from "0" to "1".

5.3.2.6 JOG

In POS_REL or POS_ABS operations it is mandatory first to set a SPEED, TARGET_ACC and a TARGET_DEC value, different from zero, before using the JOG_LEFT and JOG_RIGHT bits. In this operation mode the START_MOV bit is ignored. The motion is controlled using the JOG_LEFT and JOG_RIGHT bits of the controlword, according to the states in Table 5.8.

Table 5.8: Control word - Jog truth table.

Bit 9	Bit 8	Definition
0	0	Stop (zero speed)
1	0	Clockwise rotation
0	1	Counter-clockwise rotation
1	1	Invalid command (previous state persists)

5.3.3 Output GPIO

The OUTPUT_GPIO variable allows the control of the output located on the I/O connector (refer to Section 3.3.2). The output state changes according to the values in Table 5.9.

5.3 Cyclic data

Table 5.9: Output GPIO bitmask.

Bit	Value	Description
0	0	OUT LOW
	1	OUT HIGH

5.3.4 Target position

The TARGET_POS variable allows to set the target position used by POS_REL and POS_ABS operation modes. Target position must be given in cents of degrees or cents of mm and the unit of measurement depends upon the drive configuration (refer to the Paragraph 5.1). The sign of the variable establishes the direction of the movement.

5.3.5 Target speed

The TARGET_SPEED variable allows to set the target speed used by SPEED, POS_REL and POS_ABS operation modes. Target speed must be given in cents of RPM or cents of mm / s and the unit of measurement depends upon the drive configuration (refer to the Paragraph 5.1). The sign of the variable establishes the rotation direction for SPEED mode operation. In POS_REL and POS_ABS operations, instead, its absolute value is considered.

5.3.6 Target acceleration

The TARGET_ACC variable allows to set the target acceleration used by SPEED, POS_REL, POS_ABS and TORQUE modes of operation. Target acceleration must be given in RPM / s or mm / s² or mA / s and the unit of measurement depends upon the drive configuration (refer to the Paragraph 5.1). In TORQUE operation mode this parameter takes the meaning of "positive torque slope".

5.3.7 Target deceleration

The TARGET_DEC variable allows to set the target deceleration used by SPEED, POS_REL, POS_ABS and TORQUE modes of operation. Target deceleration must be given in RPM / s or mm / s² or mA / s and the unit of measurement depends upon the drive configuration (refer to the Paragraph 5.1). In TORQUE operation mode this parameter takes the meaning of "negative torque slope".

5.3.8 Target torque

The TARGET_TORQUE variable allows to set the target torque used by TORQUE mode of operation. Target torque must be given in mA (refer to the Paragraph 5.1).

5.3.9 Status word

The drive states are monitored by means of the STATUS_WORD variable. In Table 5.10 is given a description of its bitfield.

5.3 Cyclic data

Table 5.10: Status word.

Bit	Value	State	Description
0	0	SERVO_ON	Servo OFF (control disabled)
	1		Servo ON (control enabled)
1	0	BUSY	Drive ready to receive target
	1		Drive executing target
2	0	TARGET_REACHED	Profile executing
	1		Target has been reached
3	0	ERRORS	No errors or warnings present
	1		Errors or warnings present
4	0	HOMING_DONE	Homing missing
	1		Homing done
5	0	MANUAL_MODE	UVIX manual mode enabled
	1		UVIX manual mode disabled
6	0	SWLIM	Software limits disabled
	1		Software limits enabled
7	0	TORQUE_LIM	Torque limitation disabled
	1		Torque limitation enabled
8	0	JOG_LEFT	JOG left disabled
	1		JOG left enabled
9	0	JOG_RIGHT	JOG right disabled
	1		JOG right enabled

5.3.10 Actual mode operation

The ACTUAL_MODE_OPERATION variable returns the actual value of the MODE_OPERATION variable. After a HALT or a QUICK_STOP command, the drive remains in SPEED mode (with target speed 0 RPM or mm / s), if the previous MODE_OPERATION was SPEED or TORQUE and it remains in POS_REL, if the previous MODE_OPERATION was POS_REL or POS_ABS. After a SERVO_ON command, at the startup, the ACTUAL_MODE_OPERATION is POS_ABS.

5.3.11 Diagnostic word

The DIAGNOSTIC_WORD variable returns the state of both errors and warnings. The difference between the two is that warnings do not impact on the drive operation (they are just signaled), while errors cause the motor to stop. Both errors and warnings remain latched even if the error or warning condition disappear. To reset warning and error conditions, the reset command RES_ERR must be given (see Table 5.6). After the error reset the drive is in SERVO_OFF state, hence another SERVO_ON must be given to start movements. The only warnings that auto-reset are the "homing missing" and the "command refused" ones. Errors are divided into two categories: hard and soft. Soft errors are considered less severe and they cause a controlled stop of the motor rotation by triggering the command QUICK_STOP.

5.3 Cyclic data

Soft errors are:

- Temperature motor limit
- Temperature drive limit
- Fieldbus disconnection

All the others are hard errors and they cause the power drives to be turned off, hence the motor finishes its rotation in idle state, that is, with no control applied. In Table 5.11 is shown the bit-field of the diagnostic word: the upper 16 bits represent the errors, while the lower 16 bits represent the warnings.

Table 5.11: Diagnostic word description.

Bit	Warnings
0	VDC UVLO (< 20V)
1	VDC OVLO (> 60V)
2	VL UVLO (< 21V)
3	VL OVLO (> 27V)
4	Temperature motor limit (> 75°C)
5	Temperature drive limit (> 75°C)
6	Calibration not done
7	RESERVED
8	Homing missing
9	Target speed not reached
10	Target position not reached
11	Command refused
12 ... 15	RESERVED
Bit	Errors
16	VDC UVLO (< 10V)
17	VDC OVLO (> 80V)
18	VL UVLO (< 16V)
19	VL OVLO (> 29V)
20	Temperature motor limit (> 100°C)
21	Temperature drive limit (> 100°C)
22	Current sensors fault
23	Control fault
24	Encoder fault
25	Non volatile memory fault
26	I ² T fault
27	STO
28	Homing execution error
29	Software limits error
30 ... 31	RESERVED

NOTE: Temperature warnings don't affect the drive functionality, but they indicate the hot surface of the motor and/or the drive.

5.3 Cyclic data

5.3.12 Actual speed

The ACTUAL_SPEED variable returns the value of the actual speed of the motor. The unit of measurement depends upon the drive configuration (refer to the Paragraph 5.1).

5.3.13 Actual pos

The ACTUAL_POS variable returns the absolute value of the motor position. The unit of measurement depends upon the drive configuration (refer to the Paragraph 5.1).

5.3.14 Actual torque

The ACTUAL_TORQUE variable returns the value of the control current of the motor. The unit of measurement depends upon the drive configuration (refer to the Paragraph 5.1).

5.3.15 Inputs

The INPUTS variable returns the states of the input GPIOs present on the I/O connector (refer to Section 3.3.2), according to the bitmask described in Table 5.12. A "0" value indicates an input LOW state while a "1" value indicates an input HIGH state.

Table 5.12: Input GPIO bitmask.

Bit	Description
0	IN1
1	IN2
2	EXT PROXY INPUT
3	PROXY INPUT

Uvix

6.1 Introduction

Camozzi's proprietary environment, called UVIX, allows the user to monitor and configure all new generation Camozzi devices (*Camozzi Smart Devices*) that support connection to it. Devices can be connected to UVIX via USB. This system has been implemented with a web-based architecture so that information can be accessed straightforwardly using a browser. Monitoring consists of displaying all the device variables, whether they relate to operation, diagnostics, or parameterization.

For details on the UVIX architecture, its installation, and general operations, see the [UVIX Manual](#).

6.2 General information

6.2 General information

The devices connected to the UVIX are displayed in a tree diagram **1** consisting of *Device Groups*, *Family* and *Devices*. Select one of the components to view in the main window **2** all the information on the various devices and perform configuration operations or manual commands.

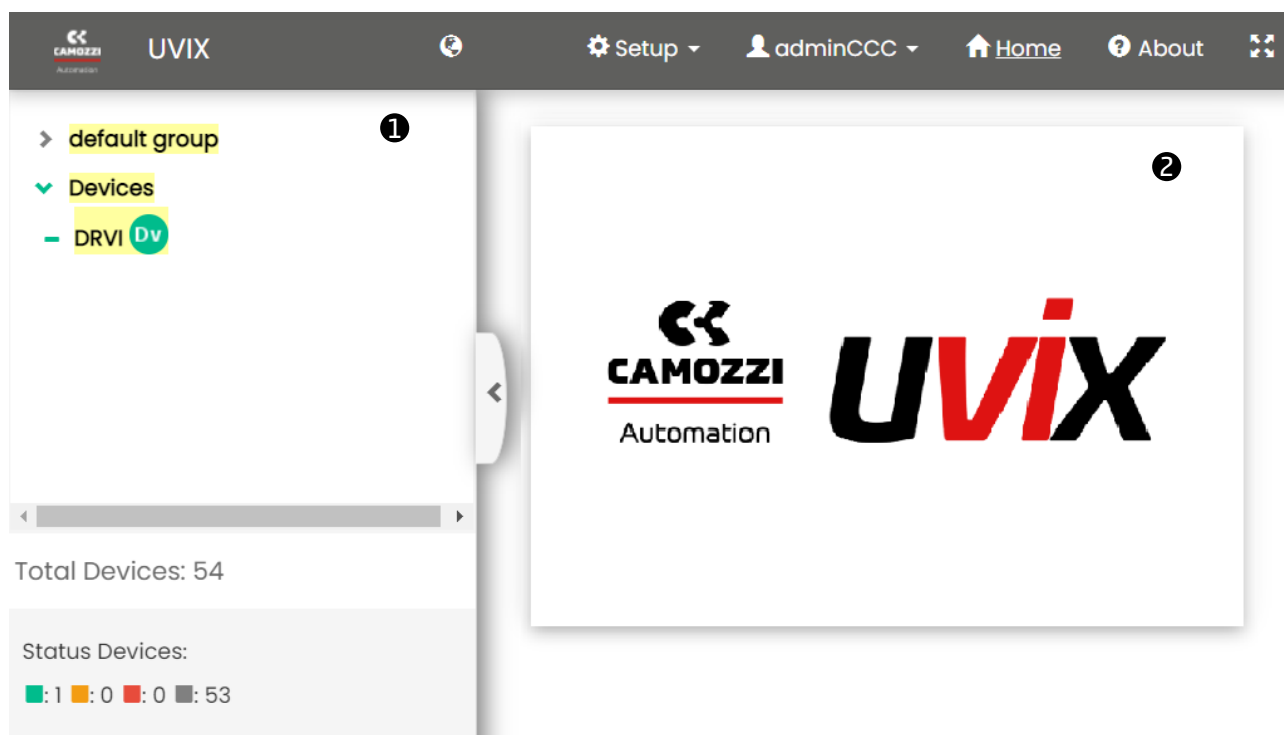

Figure 6.1: Main page of the UVIX interface.

Select the DRVI device to view the general status information and details (variables, alarms, and commands). Furthermore, it is possible to set the DRVI parameters and to communicate with the device in real-time (*Commissioning*).

6.3 Status information

6.3 Status information

- ❶ Image of the DRVI series.
- ❷ Assigned name of the device.
- ❸ Identification number of the device (17 chars).
- ❹ Family name of the device: *Series Integrated Foc Drive*.
- ❺ Subtype of the device family: *Drvi Stepper/Brushless Motor*.
- ❻ Firmware version.
- ❼ Date and time of the last data transmission.
- ❽ General status of the device: ● Not available, ● Ok, ● Warning, ● Alarm.
- ❾ Operational status of the device:
 - *Work*: normal operation.
 - *Manual*: manual operation.
- ❿ Connection status: ● Ok, ● Offline.
- ⓫ Fieldbus communication: Profinet/EtherCAT/CANopen.
- ⓬ Communication status of the Fieldbus: ● Ok, ● Offline.
- ⓭ Fieldbus configuration (par. 6.7).
- ⓮ DRVI parameters configuration (par. 6.5).
- ⓯ Commissioning device (par. 6.6).

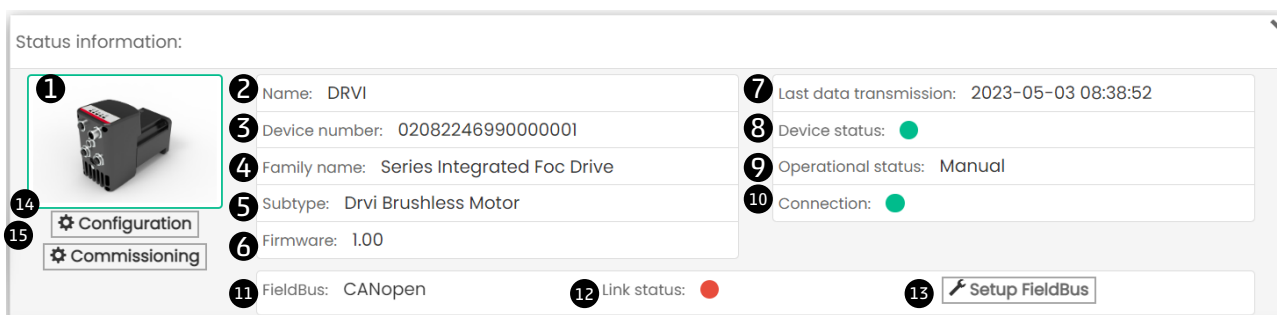

Figure 6.2: Main page of the UVIX interface.

6.4 Details



6.4.1 Variables

The first tab of the details page deals shows the variables that are monitored by the DRVI device as shown in Figure 6.3.



- Motor Size: *Nema 17, Nema 23, Nema 24.*
- Brake: *Present or Not present.*
- STO: *Present or Not present.*
- Actuator type:
 - *Only motor*
 - *Custom actuator*
- V Logic: supply voltage for the device controller circuit board. Without this supply voltage, the device is turned off.
- V Bus: bus voltage in.
- T Motor: motor temperature in °C.
- Servo state: *On or Off.*
- Mode of operation:
 - *Homing*
 - *Speed*
 - *Relative positioning*
 - *Absolute positioning*
 - *Torque*
- Busy state: *True or False.*
- Homing state: *Present or Not present.*
- Actual pos: actual position measured in angular degrees or mm.
- Actual vel: actual velocity measured in RPM or mm / s.
- Actual torque: actual torque (current) measured in mA.
- Total stroke: total stroke measured in m.
- Total time on: total time on measured in hours.
- Total time off: total time off measured in hours.
- Total time run: total time run measured in hours.
- Power: power consumption measured in watt hour.
- Output GPIO: *On or Off.*
- Input 1: *On or Off.*
- Input 2: *On or Off.*
- Input proxy external: *On or Off.*
- Input proxy homing: *On or Off.*

6.4.2 Alarms

The second tab on the details page displays possible DRVI alarms as shown in Figure 6.4.

- Error alarms: *Alarm active*  , *Alarm not active*  .
 - *VBUS under voltage.*

6.4 Details

- VBUS over voltage.
- VLOG under voltage.
- VLOG over voltage.
- Motor temperature.
- Drive temperature,
- Over current.
- Fault in control loop.
- Encoder fault.
- Non-volatile memory fault.
- Energy dissipation fault.
- STO fault.
- Homing fault.
- Warning alarms: *Alarm active* , *Alarm not active* .
- VBUS under voltage.
- VBUS over voltage.
- VLOG under voltage.
- VLOG over voltage
- Motor temperature.
- Drive temperature.
- Homing not done.
- Target speed not reached.
- Target position not reached.
- Invalid command.
- Position limit reached.

6.4 Details

Details: ▼

▮ Variables
🔔 Alarms
📡 Commands

Name	Value
Motor size	Nema 23
Brake	Not present
STO	Not present
Actuator type	Only motor
V Logic	23.3 V
V Bus	23.7 V
T Motor	27.8 °C
Servo state	On
Mode of operation	Homing

Figure 6.3: Section for the variables monitored by the DRVI device.

Details: ▼

▮ Variables
🔔 Alarms
📡 Commands

Event Name	Status ▼	Event Onset
Drive temperature	🟢	
Over current	🔴	
Fault in control loop	🔴	
Encoder fault	🔴	
Non-volatile memory fault	🔴	
Energy dissipation fault	🔴	
VBUS under voltage	🟡	
VBUS over voltage	🟡	
VLOG under voltage	🟡	

Figure 6.4: Section for the alarms monitored by the DRVI device.

6.4 Details

6.4.3 Commands

The third tab of details on the DRVI device shows the commands that can be sent via UVIX to the device. The *Manual Mode* command allows you to control the system manually from UVIX, sending configuration parameters to the DRVI. In manual mode, it is possible to reset the alarms ❶, to set the digital output ❷, to start or stop the motor movement ❸, and to switch on/off the servo ❹. The history of the commands sent to the DRVI since the communication with UVIX was started can be viewed under Last Commands ❺.

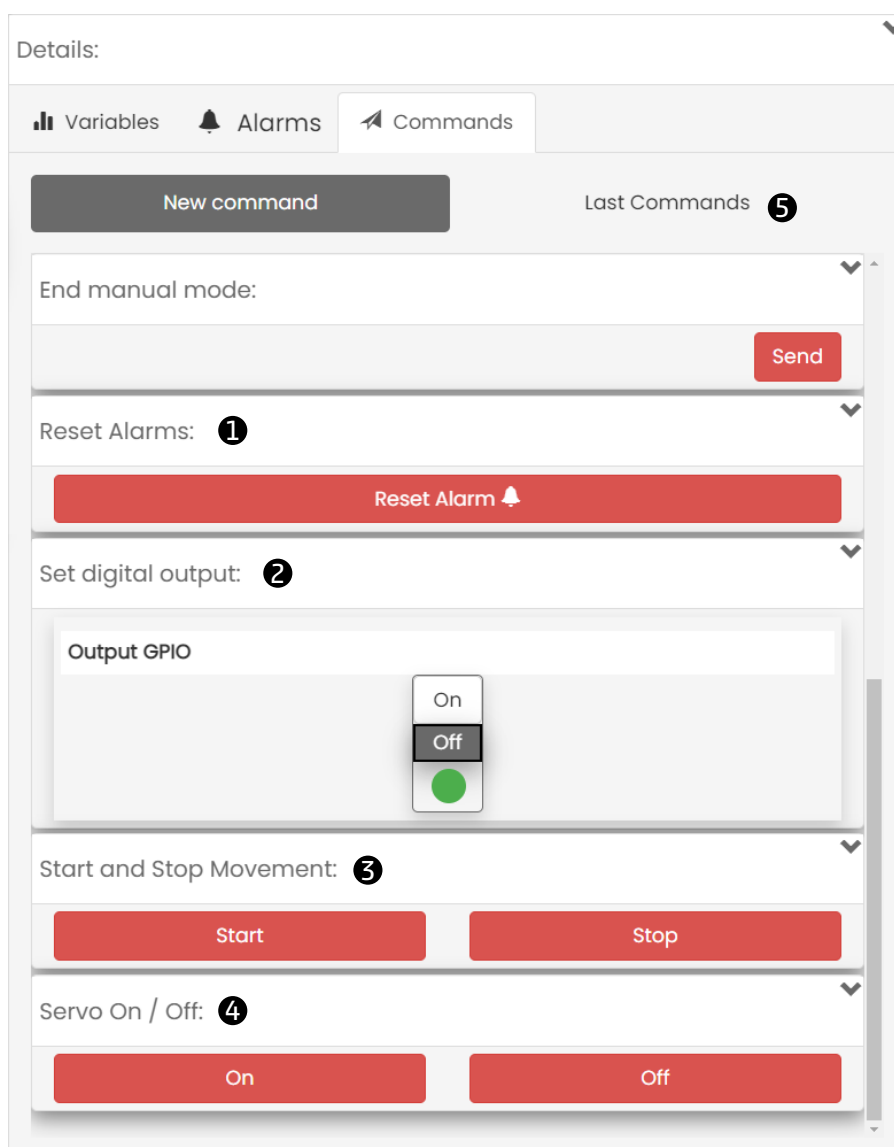

Figure 6.5: Section for the commands managed by the DRVI device.

6.5 Configuration

6.5 Configuration

From the status information page, you can configure certain operating-related parameters of the DRVI: actuator, motion and communication. All these parameters can be stored into the non volatile memory of the drive by clicking the buttons "Send" and subsequently "Save on device".

6.5.1 Actuator

In the actuator section it is possible to set the following parameters:

- ❶ The type of actuator:
 - *Only motor*
 - *Custom Actuator*
- ❷ Gear ratio. If a gear is placed between the drive and the actuator, you can use this parameter to apply an automatic scale of the target (i.e.: profile parameters are multiplied by the gear ratio value).

The following items are software limits, that can be used to restrict the profile parameters:

- ❸ Actuator screw pitch measured in mm / round. This parameter allows the conversion to linear measurement units, when an actuator is connected to the drive.
- ❹ Actuator limits (if ON, it enables to modify the limit values).
- ❺ Actuator minimum stroke measured in mm (such value must be lesser than ❻).
- ❻ Actuator maximum stroke measured in mm (such value must be greater than ❺).
- ❼ Actuator max speed measured in mm / s.
- ❽ Actuator max acceleration measured in mm / s².
- ❾ Actuator max deceleration measured in mm / s².

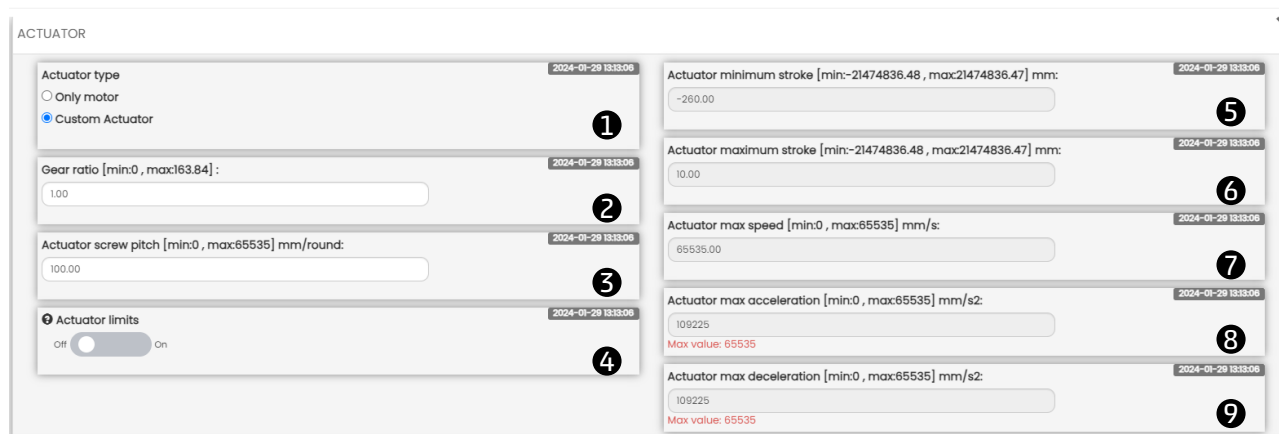

Figure 6.6: Section for actuator configuration.

6.5.2 Motion

In the motion section is possible to set the follows parameters:

- ❿ Profile check: *No* or *Yes*. Enable or disable the check of the actual rotor position, with respect to the target imposed.
- ⓫ Direction of movements: *standard* or *inverse* (with respect to convention, see Paragraph 5.1).

6.5 Configuration

- 11 Profile check timeout measured in ms. If "Profile check" is enabled, this parameters represents the time after which an error is returned, if the actual rotor position does not match the imposed one.
- 12 Quick stop deceleration measured in mm / s².
- 13 Hardware jog mode *No* or *Yes*. Enable or disable the jog mode.

MOTION

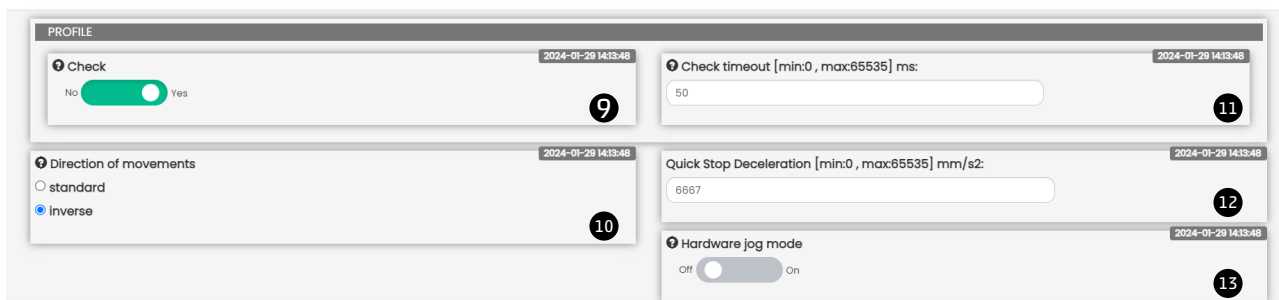

Figure 6.7: Section for motion configuration.

6.5.3 Communication

In the communication section it is possible to set the data endianness used by the fieldbus 13 : *little endian* or *big endian*.

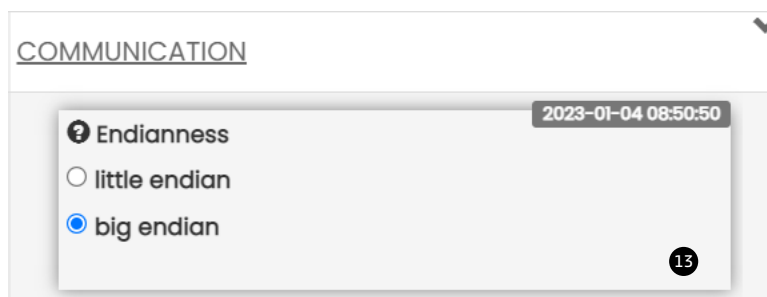

Figure 6.8: Section for communication configuration.

6.5.4 GPIO

In the GPIO section it is possible to set the polarity of the I/O.

GPIO



Figure 6.9: Section for I/O polarity.

6.6 Commissioning

6.6 Commissioning

From the commissioning page it is possible to move the drive, as well as configure some of its parameters. Homing parameters and PID configuration can be stored into the non volatile memory of the drive by clicking the buttons "Send" and subsequently "Save on device".

6.6.1 DRVI states

- ❶ States of the DRVI: it is possible to watch the state of the DRVI, the state of the inputs, set the state of the output and if a fault is active
- ❷ Variables measured in fast mode.
- ❸ Command of the manual mode: *Start or End*.
- ❹ Command of the servo: *On or Off*.
- ❺ Mode operation:
 - *None*
 - *Homing*
 - *Speed*
 - *Absolute position*
 - *Relative position*
 - *Torque*
- ❻ Start and stop of the movement: *Start, Stop*.
- ❼ Reset errors and warnings: *Reset Alarm*.

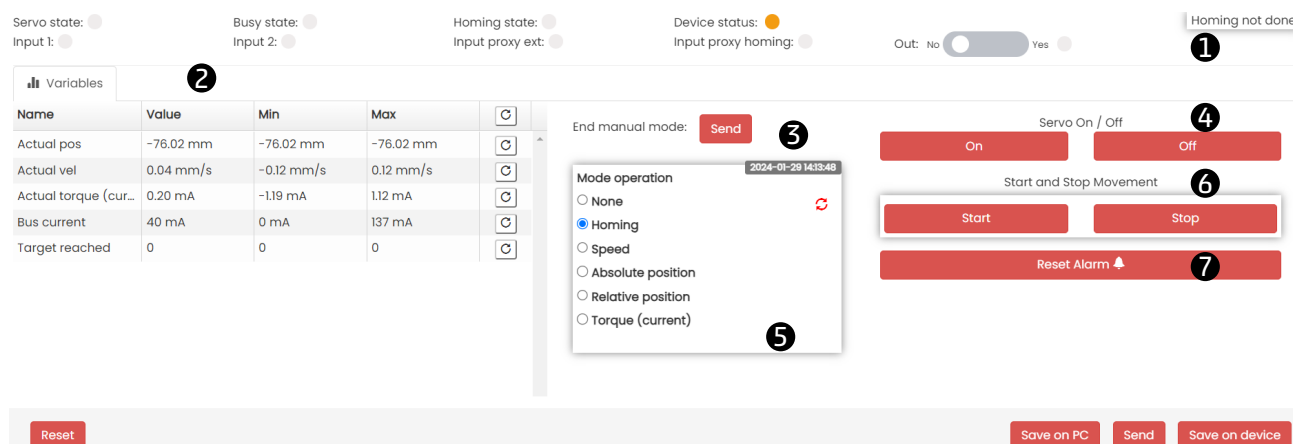

Figure 6.10: Section of the fast mode variables and DRVI states.

In case the mode of operation ❺ is set to Speed, Absolute position, Relative position or Torque the Start and Stop Movement ❻ change as in Figure below.

- ❶ Start Profile1: this is the first target value.
- ❷ Start Profile2: this is the (optional) second target value.
- ❸ Stop: it ends the current movement.
- ❹ Timeout: it set the delay in seconds between profile1 and profile2 target. BE CAREFUL: set a value that is greater than the time elapsed to execute the movement set with profile1 and profile2 target
- ❺ Loop cycle *No, Yes*: it enables the loop of movements between profile1 and profile2 target.

6.6 Commissioning

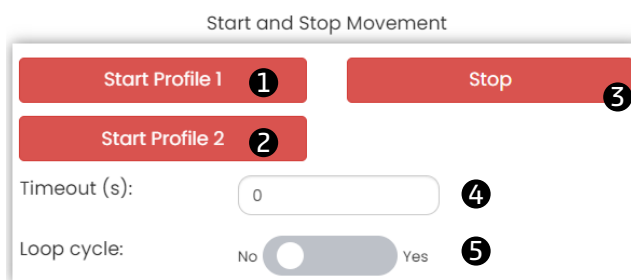

Figure 6.11: Section of the Start and Stop for not Homing modes.

6.6.2 Mode operation parameters

6.6.2.1 Homing

- ⑧ Homing type:
 - Without proximity
 - Proximity left
 - Proximity right
 - Proximity left + zero encoder
 - Proximity right + zero encoder
 - Torque left
 - Torque right
 - Torque left + zero encoder
 - Torque right + zero encoder
- ⑨ Homing speed search measured in RPM or mm / s.
- ⑩ Homing acceleration search measured in RPM / s or mm / s².
- ⑪ Homing deceleration search measured in RPM / s or mm / s².
- ⑫ Homing speed out measured in RPM or mm / s.
- ⑬ Homing acceleration out measured in RPM / s or mm / s².
- ⑭ Homing deceleration out measured in RPM / s or mm / s².
- ⑮ Homing timeout measured in ms.
- ⑯ Homing offset measured in angular degrees or mm.
- ⑰ Torque homing threshold % with respect to the I²T value.

Homing "search" parameters (e.g.: "Homing speed search") are the ones used to find the proximity (or the end of the line), while "out" parameters (e.g.: "Homing speed out") are the ones used to exit from the proximity (or the end of the line).

6.6 Commissioning

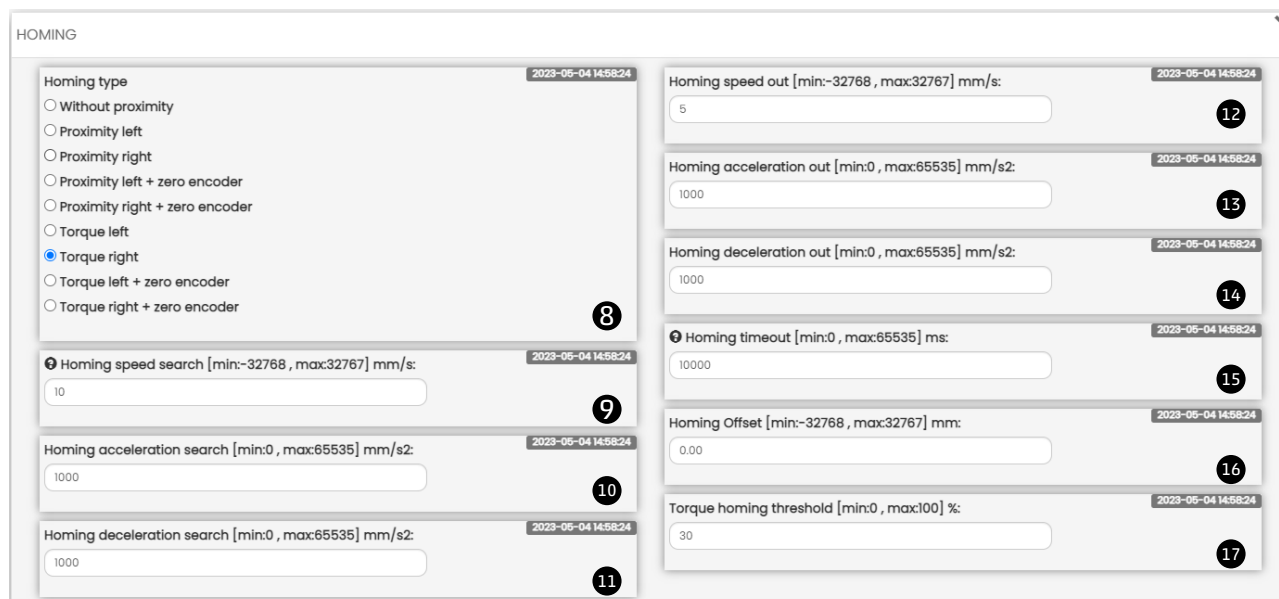

Figure 6.12: Section of the homing parameters.

6.6.2.2 Speed Profile

In the speed profile section it is possible to set the motion profile parameters for the speed control for 2 target speed, profile1 and (optional) profile2. Moreover it is possible to enable/disable the check of the Torque limit and its threshold value in mA:

- ⑧ Target speed measured in RPM or mm / s.
- ⑨ Target acceleration measured in RPM / s or mm / s².
- ⑩ Target deceleration measured in RPM / s or mm / s².
- ⑪ Torque limit enable *No*, *Yes* ².
- ⑫ Target torque limit measured in mA ².

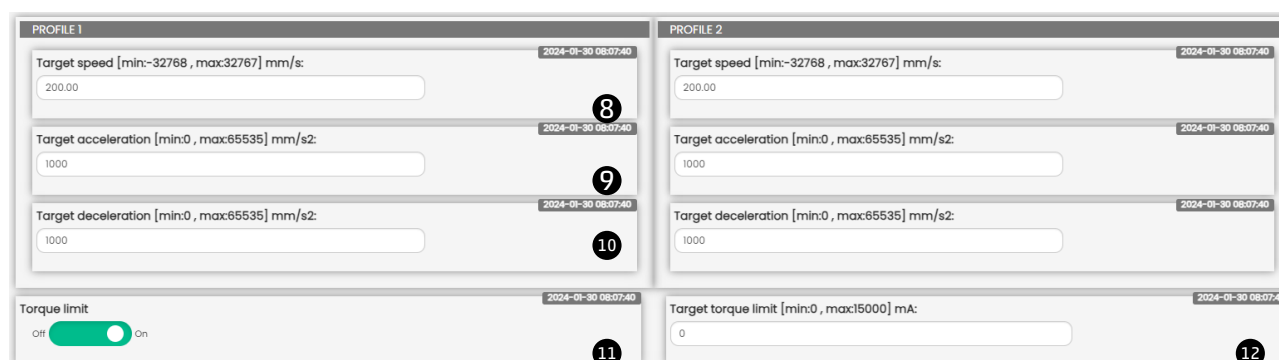

Figure 6.13: Section of the speed profile parameters.

6.6.2.3 Absolute position

In the absolute position section it is possible to set the motion profile parameters for the absolute position control for 2 target positions, profile1 and (optional) profile2. Moreover it is possible to enable/disable the check of the Torque limit and its threshold value in mA:

- ⑧ Target speed search measured in RPM or mm / s.
- ⑨ Target acceleration measured in RPM / s or mm / s².

6.6 Commissioning

- 10 Target deceleration measured in RPM / s or mm / s².
- 11 Target position measured in angular degrees or mm.
- 12 Torque limit enable *No, Yes* ².
- 13 Target torque limit measured in mA ².

ABSOLUTE POSITION PROFILE

Figure 6.14: Section of the absolute position profile parameters.

6.6.2.4 Relative position

In the relative position section it is possible to set the motion profile parameters for the relative position control for 2 target positions, profile1 and (optional) profile2. Moreover it is possible to enable/disable the check of the Torque limit and its threshold value in mA:

- 8 Target speed search measured in RPM or mm / s.
- 9 Target acceleration measured in RPM / s or mm / s².
- 10 Target deceleration measured in RPM / s or mm / s².
- 11 Target position measured in angular degrees or mm.
- 12 Torque limit enable *No, Yes* ².
- 13 Target torque limit measured in mA ².

RELATIVE POSITION PROFILE

Figure 6.15: Section of the relative position profile parameters.

6.6 Commissioning

6.6.2.5 Torque profile

In the torque profile section it is possible to set the motion profile parameters for the torque (current) control for 2 target positions, profile1 and (optional) profile2:

- ⑧ Target torque (current) measured in mA.
- ⑨ Target slope acceleration measured in mA / s.
- ⑩ Target slope deceleration measured in mA / s.

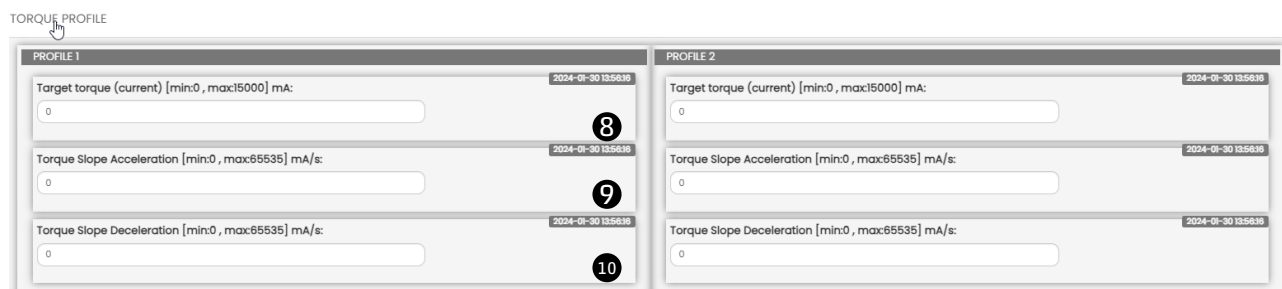

Figure 6.16: Section of the torque profile parameters.

6.6.3 PID

The PID section allows to set the PID values used in motion profiles ⑰ :

- Default
- Low load
- Medium load
- High load
- Custom

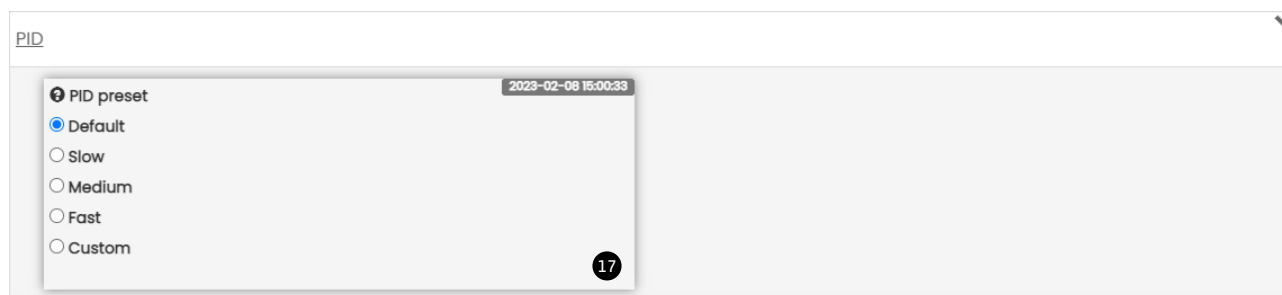

Figure 6.17: Section of the PID control.

PID parameters can be fully customized (see Figure 6.18):

- ⑱ KP speed
- ⑲ KI speed
- ⑳ KP position

6.7 Profinet configuration

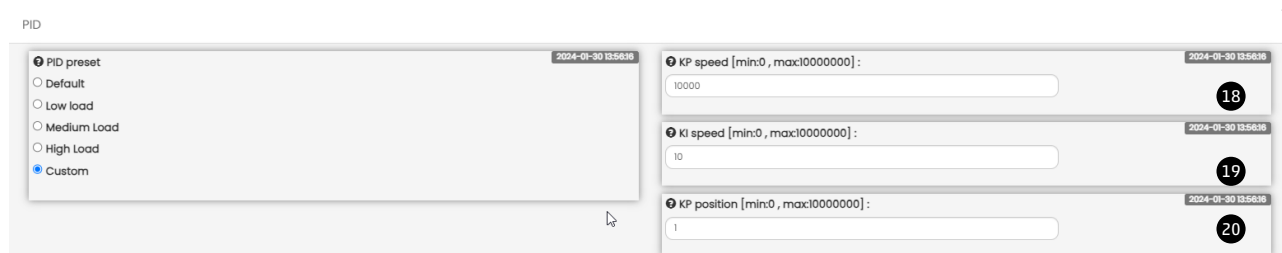

Figure 6.18: Section of the custom PID control.

6.7 Profinet configuration

From the status information page, you can access the window for configuring certain fieldbus parameters. In the specific case of Profinet, you can configure the unique station name **1**, the IP address **2**, the mask **3** and the gateway address **4** of the device. Using the buttons in the bottom bar of the configuration window **5**, the configured parameters can be sent to the module, saved on the PC, saved on the device, or reset to default values.

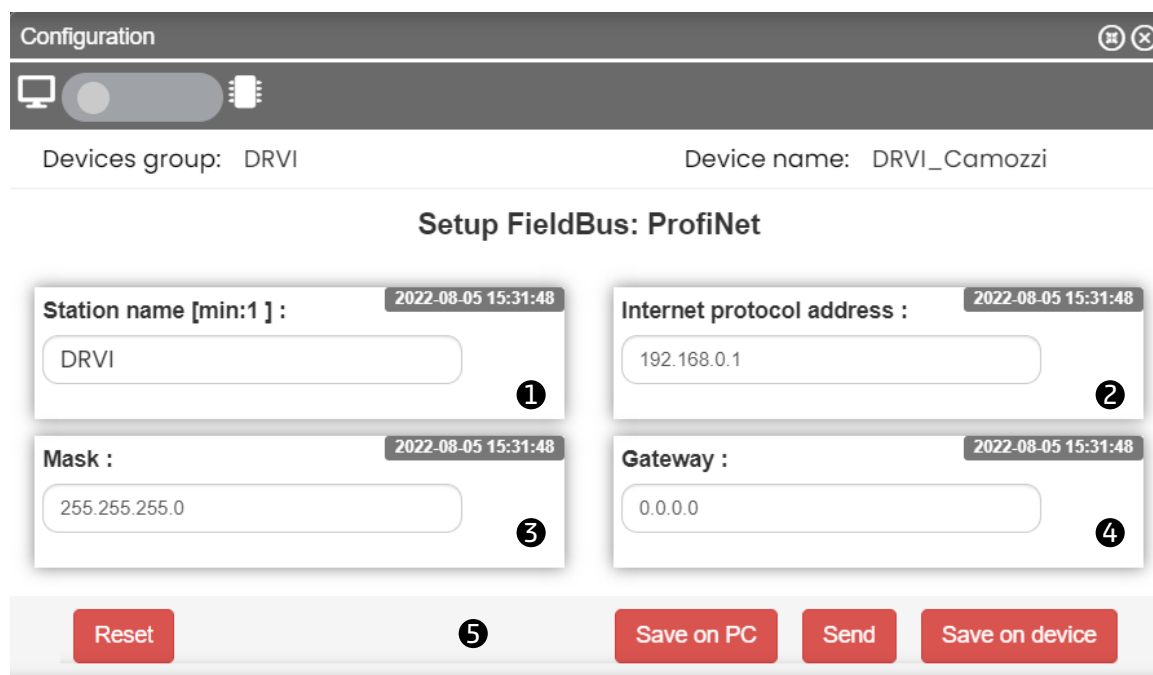

Figure 6.19: Section of the Profinet parameters configuration.

The fieldbus default values are shown in Table 6.1.

Table 6.1: Fieldbus default values.

Parameter	Value
Station name	-
IP address	0.0.0.0
Mask	255.255.255.0
Gateway	0.0.0.0

6.8 UVIX USB Gateway

6.8 UVIX USB Gateway

The DRVI can be connected to a PC via a USB cable. This connection - subject to prior installation of UVIX on the PC - allows you to communicate with the module through the Camozzi USB Gateway.

6.8.1 Main page

- ① Toolbar: for managing all the functionalities of the USB Gateway.
- ② USB Gateway Commands: to start or stop the USB Gateway and open the webApp.
- ③ Status: indicates the status of the USB Gateway.
- ④ Open COMs: List of devices currently communicating.
- ⑤ Virtual COM ports available and addresses of TCP connection for the connected COM ports.
- ⑥ Data received from the COM port
- ⑦ Data received on the FEP of the UVIX system.

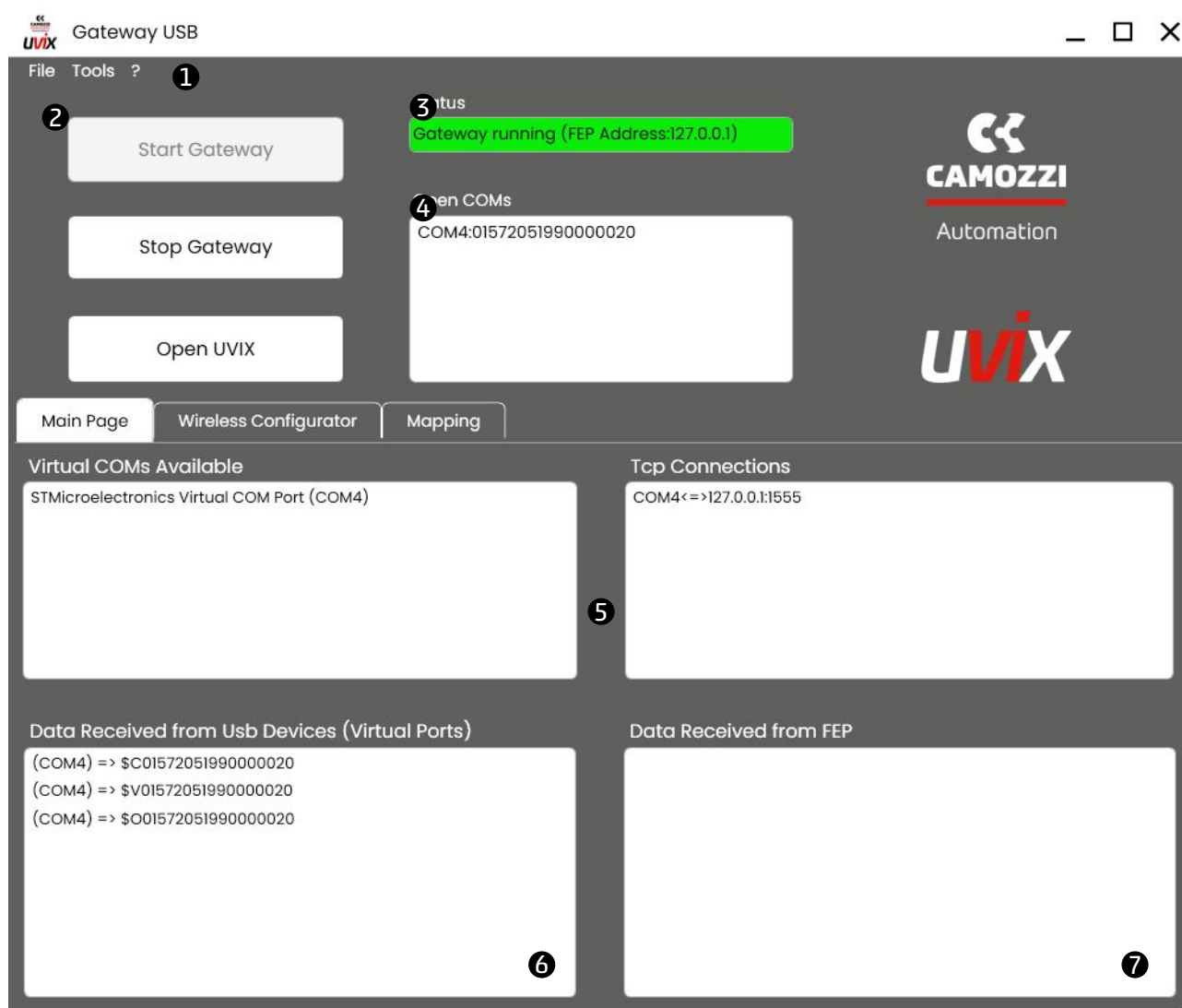

Figure 6.20: Gateway USB.

6.8 UVIX USB Gateway

6.8.2 Firmware update

⚠ Before carrying out this operation, you must contact Camozzi support.

The USB Gateway allows you to update the firmware of the DRVI module through the window found under Tools -> Device Upgrade (NO DFU) **8** (see Figure 6.21).

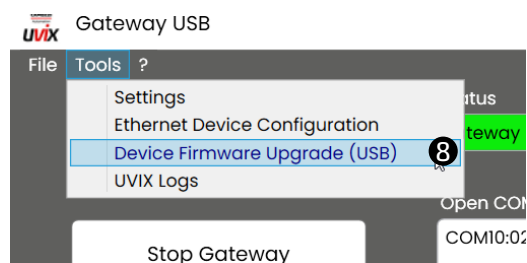

Figure 6.21: Firmware upgrade selection.

The device update window will appear (see Figure 6.22):

- **1** Current FW version.
- **2** Device to be upgraded.
- **3** Button to select binary firmware file.
- **4** New firmware binary file.
- **5** Start upgrade procedure.

Drives Upgrade



Figure 6.22: Firmware upgrade window.

Contacts

Camozzi Automation S.p.A.

REGISTERED OFFICE:

Via R. Rubattino, 81 - 20134 Milano (Italy)
P.IVA IT 03207930177

OPERATIONAL HEADQUARTERS:

Via Eritrea, 20/I - 25126 Brescia (Italy)
Tel. +39 03037921 | Info@camozzi.com
www.camozzi.com

Technical assistance

Tel. +39 030 3792790
service@camozzi.com

Product certification

Information concerning product certifications,
EC standards, conformity declarations and instructions
productcertification@camozzi.com



Automation

