

**SERIES FS01**  
DIGITAL FLOW SENSOR





# Contents

<b>Chapter 1 Introduction</b>	<b>1</b>
1.1 Product Safety Instructions	1
<b>Warning</b>	
1.2 Precautions for use	1
1.3 Working fluid and working environment	2
1.4 Wiring Precautions	2
1.5 Installation Precautions	2
1.6 Other Precautions	3
<b>Caution</b>	
1.7 Installation Precautions	3
1.8 Maintenance Precautions	3
1.9 Disposal	3
<b>Warning</b>	
1.10 Fluid	4
1.11 Disclaimer	4
<b>Chapter 2 Installation Instructions</b>	<b>2</b>
2.1 Piping	5
Piping for the One-Touch Fitting	
Piping for the internal thread	
2.2 Mounting bracket	7
2.3 Wiring Diagrams	8
PNP output, Analog output and external input	
<b>Chapter 3 How to Use</b>	<b>3</b>
3.1 Names and Functions of Individual Parts	9
3.2 Functions Instructions	10
3.3 Operation Instructions	12
<b>Chapter 4 Instruction</b>	<b>4</b>
4.1 Error Code Instruction	39
<b>Chapter 5 Specifications</b>	<b>40</b>
<b>Chapter 6 Thermal Mass Principles of Flow Sensor</b>	<b>41</b>
<b>Chapter 7 Ordering Information</b>	<b>42</b>
<b>Chapter 8 Dimensions</b>	<b>43</b>
<b>Chapter 9 Construction</b>	<b>45</b>
<b>Chapter 10 Pressure Loss Characteristics</b>	<b>46</b>

# Introduction

## 1.1 Product Safety Instructions

This section indicate the levels of risks with the labels of Danger, Warning and Caution.



**Danger** indicates high level of risk, will lead to fatal or serious injuries if not avoided.

---



**Warning** indicates medium level of risk, it might cause death or serious injuries.

---



**Caution** indicates low level of risk, it might result in minor injuries, such as scald, electric shock, etc. and the product, equipment and machines might be damaged.

## Warning

### 1.2 Precautions for use

- **Operate within the specified voltage.**

Malfunction or damaged product, electric shock or fire may be resulted by exceeding the specified voltage range.

- **Do not exceed the maximum load current.**

It may damage the product.

- **Do not use any load that generates surges.**

Surge protection is present but applying surge voltage repeatedly will ultimately damage the product.

When using with inductive load (such as relay or solenoid), please install a flyback diode across the load (polarity must be observed).

- **Observed the internal voltage drop.**

When used at a specified voltage, if the sensor is functional but the load does not work, please check if the operating voltage of the load meets the following formula.

---

Power Supply voltage – Internal voltage drop of sensor > Minimum operating voltage of load

---

- **Please follow the rated range of flow and pressure to avoid damage.**

- **Do not use flammable fluids and/or permeable fluids.**

They may cause fire, explosion or corrosion.

### 1.3 Working fluid and working environment

- **Do not use in an explosive gas atmosphere.**  
The sensor does not have explosion-proof structure, fire, explosion or corrosion can result.
- **Do not use near a surge voltage generated area.**  
If product is nearby the device of surge voltage (e.g., lightning strikes, solenoid lifters, high frequency induction furnaces, motors, etc.), please take measures against the surge sources to prevent damage.
- **Do not use in an environment where sensors could be splashed by water or oil.**  
Enclosure rating is IP40, please avoid water or oil splashed environment to prevent adversely effects.
- **Do not use in an environment subject to large temperature cycling.**  
Internal components of the sensor will be damaged by large heating/cooling cycles other than ordinary changes in temperature.
- **Do not mount the product in locations where it is exposed to radiant heat.**

### 1.4 Wiring Precautions

- **Check wire color and terminal number when wiring.**  
Incorrect wiring can cause permanent damages to the sensor, check wire color and terminal number according to the manual before wiring.
- **Avoid repeatedly bending or stretching the lead wire.**  
It can cause damage to the sheath, or breakage of the wire.
- **Confirm wiring insulation**  
Please avoid poor insulations (and interference from another circuit, poor insulation between terminals, etc.) it can lead to over current being applied to the product, causing damage.
- **Please use a separate route for the product wiring and any power or high voltage wiring to avoid noise interruption.**
- **Do not short-circuit the load.**  
When the load is short-circuited, an error will be displayed. But excess current may cause damage to the sensor.
- **Do not connect wire when the power is on.**
- **RS485 products must be connected the communication wire first.**  
Wiring for RS485 MODBUS : Please connect RS485 (B+) or (A-) before connecting power supply to avoid short circuit to damage to product.

### 1.5 Installation Precautions

- **Ensure the flow direction of the fluid.**  
Install the pipe by following the arrow indication that shows the air flow direction on the product.
- **Flush out all dirt and dust by air blow before connecting the piping to the sensor.**
- **Do not drop or hit.**  
When installation, do not drop, hit or apply excessive shock (100m/s<sup>2</sup>), permanent damage to the internal component of the sensor may occur.

## 1.6 Other Precautions

---

- **Do not install multiple products in close proximity.**

The heat generated from each product could cause the temperature to rise and change the characteristics of product or deterioration of the plastic parts. Please set the products 10mm apart from each other.

- **Hold the sensor body when installing.**

The tensile strength of the cable is 24.5 N and apply excessive pulling force can cause damage to the sensor.

## 1.6 Other Precautions

- **After power is supplied, the output will remain off until the display is turned on. Please operate the sensor after the value is shown.**

- **Stop the control systems before perform setting changes.**

During the initial flow and pressure setting, the product will switch the output according to the existing settings until the changes are complete.

### Caution

## 1.7 Installation Precautions

- **Please follow the specified tightening torque.**

- **Do not mount the sensor in a place that will be used as a foothold.**

The product may damage if sit or step on it accidentally.

- **When mounting without a bracket, please use P type self-tapping screw- M3 x L 6mm.**

- **Do not remove the fixed pin for the One-Touch Fitting.**

To avoid losing the internal parts and cause malfunction.

- **Please do not replace fittings by yourself.**

- **While installing the FS01-201 to the pipe, please apply air tube with I.D. 5 mm.**

**While installing the FS01-010/500 to the pipe, please apply air tube with I.D. 4 mm.**

## 1.8 Maintenance Precautions

- **The accuracy could change by 2 to 3% when the piping is removed or replaced.**

- **Do not touch terminals or connectors when power is on.**

## 1.9 Disposal

- **Sensors at end-of-life must be disposed of in accordance with E-Waste regulations of the country/region, NOT disposed of with regular garbage.**

## 1.10 Fluid

### Warning

#### 1.10 Fluid

- **Check the regulator and flow adjustment valve before introducing the fluid.**
- **On the inlet side, be sure to install an air filter below the filtration level of 10um.**  
The sensing element cannot measure properly if foreign matter adheres to it.
- **Recommended Equipments and Installation**

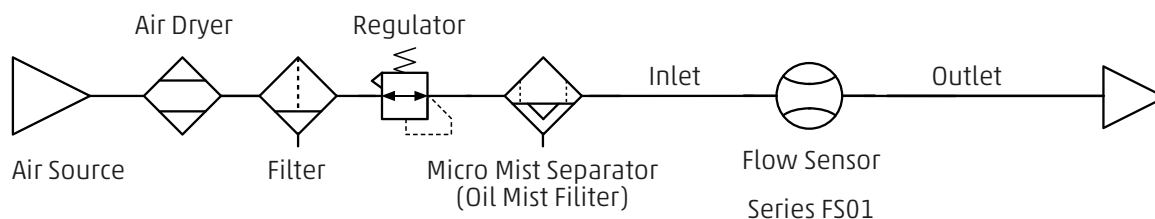

#### NOTE

When measuring the pressure of the inlet side, install a throttle valve or solenoid valve on the outlet side.  
When measuring the pressure of the outlet side, install a throttle valve or solenoid valve on the inlet side.

- **Recommended Equipments and Installation Example**

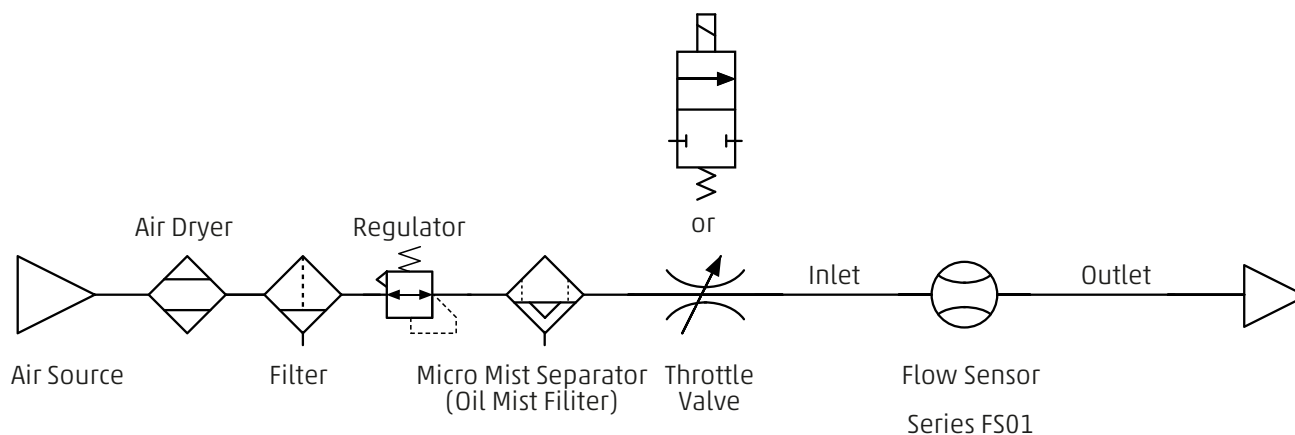

## 1.11 Disclaimer

- Our warranty applies solely to our product, not to any other damages and injuries which occur by earthquakes, fires, the acts by third party, other matters, acts intentionally, acts accidentally, misuse, or other abnormal conditions that are not the responsibility of CAMOZZI AUTOMATION.
- Our warranty applies solely to our product, not to any other additional damages (the loses of business profits, business interruption, etc.) incurred due to using or misusing the product.
- Our warranty excludes any injuries and damages that happened by using the product beyond the specified range of function stated in the catalog or the instruction manual.

# Installation Instructions

## 2.1 Piping

### Piping for the One-Touch Fitting

Install the pipe by following the arrow indication that shows the air flow direction on the product.

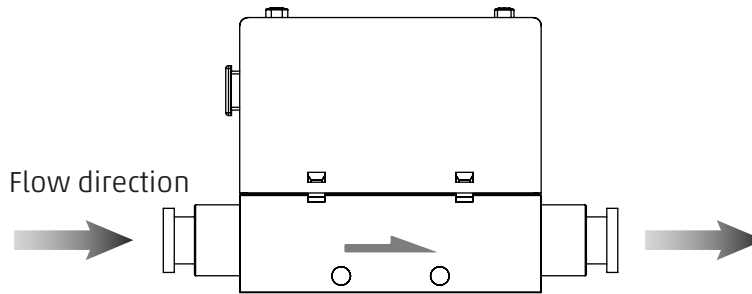

Use straight piping 8cm or longer to connect the Piping Port (Inlet side). If straight piping is not installed, the accuracy may vary by  $\pm 2\%$  F.S.

Straight Piping: The pipe is without bending and the cross sectional areas of the pipe keeps the same.

While installing the FS01-201 to the pipe, please apply air tube with I.D. 5 mm.

While installing the FS01-010/500 to the pipe, please apply air tube with I.D. 4 mm.

The accuracy can vary by approximately  $\pm 2\%$  F.S. when such tubing is not used.

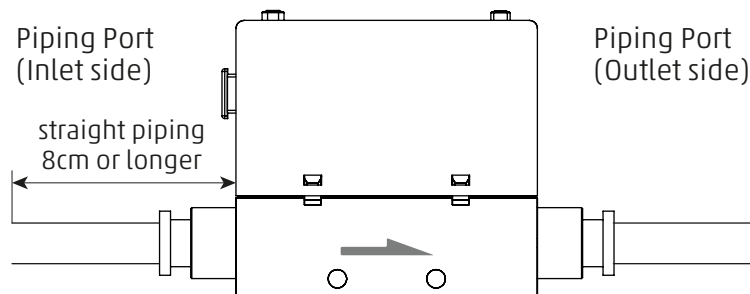

Blow the air to flush out the foreign matters, dust and etc. before installing the pipe.

Uncleaned air may cause malfunction or damage to the product.

Piping for the One-Touch Fitting, insert the tube firmly into the fitting and make sure it cannot be pulled out.

Also using the proper tube cutter is recommended to ensure square edge tube.

Recommends using PU tube.

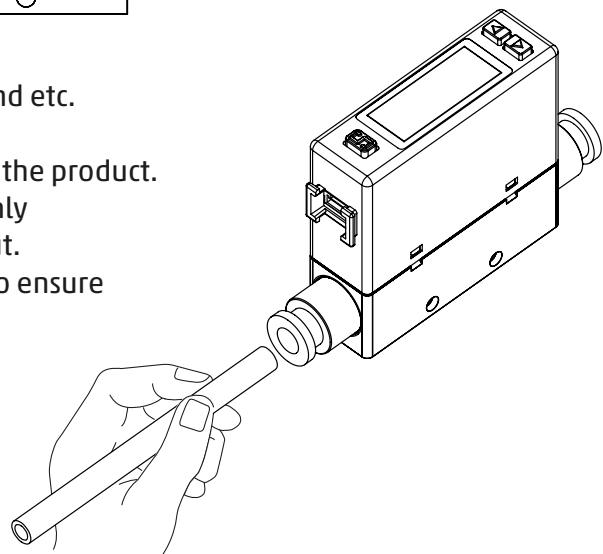



## 2.1 Piping

### Piping for the internal thread

Install the pipe by following the arrow indication that shows the air flow direction on the product.

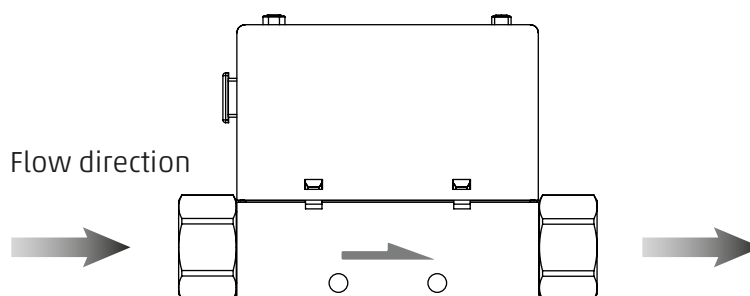

Use straight piping 8cm or longer to connect the Piping Port (Inlet side). If straight piping is not installed, the accuracy may vary by  $\pm 2\%$  F.S..

**Straight Piping:** The pipe is without bending and the cross sectional areas of the pipe keeps the same.

While installing the FS01-201 to the pipe, please apply air tube with I.D. 5 mm.

While installing the FS01-010/500 to the pipe, please apply air tube with I.D. 4 mm.

The accuracy can vary by approximately  $\pm 2\%$  F.S. when such tubing is not used.

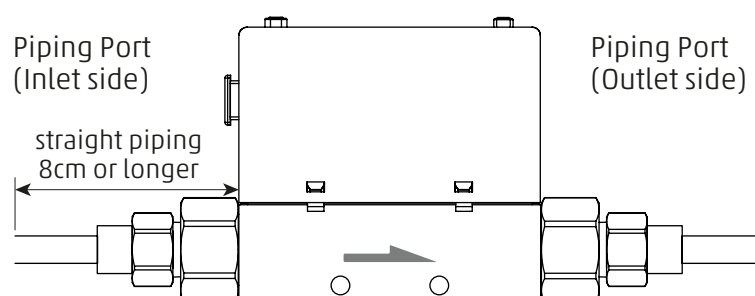

When mounting the fitting, a wrench should be used on the metal part.

Using on other parts of the product with a wrench may damage the product.

If the tightening torque is exceeded, the product can be broken.

If the tightening torque is insufficient, the fitting may become loose and cause air leakage.

Please refer to the applicable torque below.

After installation completed, turn on the gas and power supply for proper operation and leaking test to confirm whether the installation is correct.

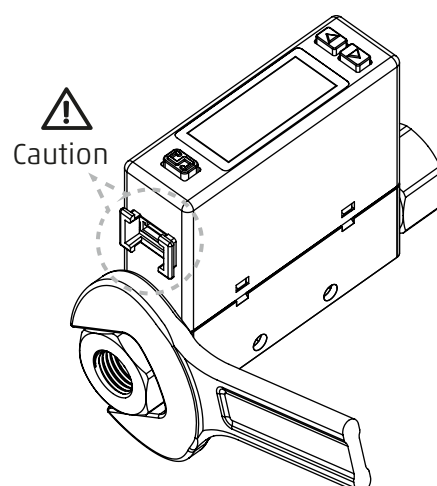

Piping Specification	Required Torque
Rc 1/8"	4 ÷ 7 N.m
Rc 1/4"	6 ÷ 8 N.m

## 2.2 Mounting Bracket / Optional Parts

### 2.2 Mounting Bracket / Optional Parts

The LCD display may be difficult to see at certain angles.

The sensor can be installed horizontally or vertically, but the flow rates may change because of the installation way of the product or piping.

The tightening torque for screws should be under  $0.5 \pm 0.1$  N.m.

#### 1 . Horizontal mounting (by Through-Hole)

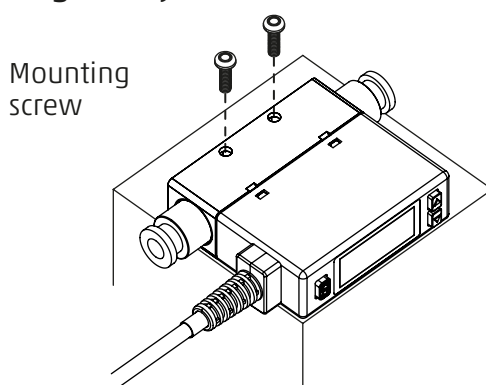

#### 2 . Bracket mounting

Mounting screw

P Type  
Size: 3.0  
Length: 6mm

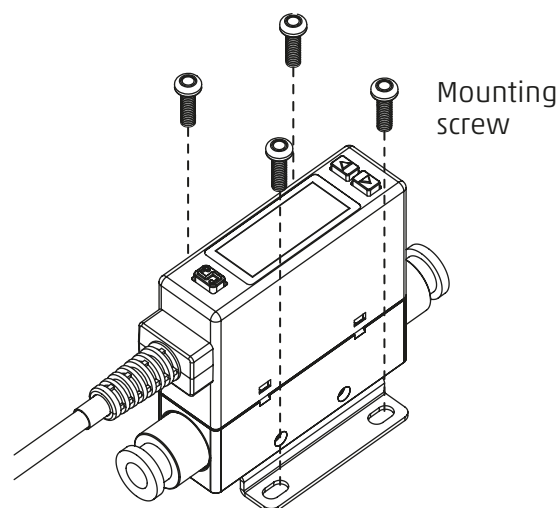
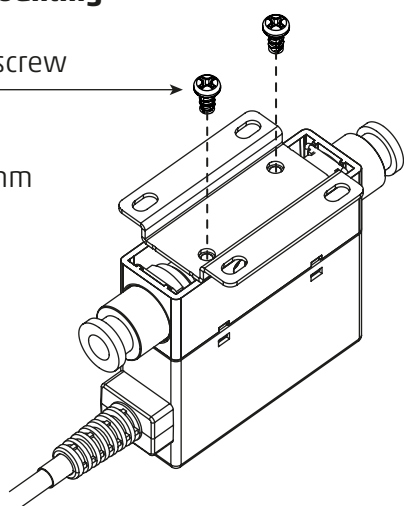

The tightening torque for screws should be under  $0.5 \pm 0.1$  N.m.

#### 3 . Panel mounting

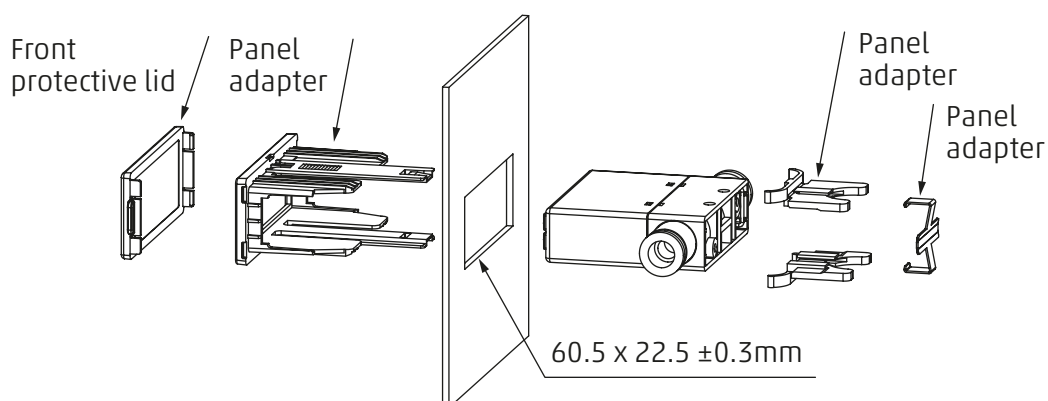

## 2.3 Wiring Diagrams

### 2.3 Wiring Diagrams

- PNP Output / Analog Voltage Output / External Input

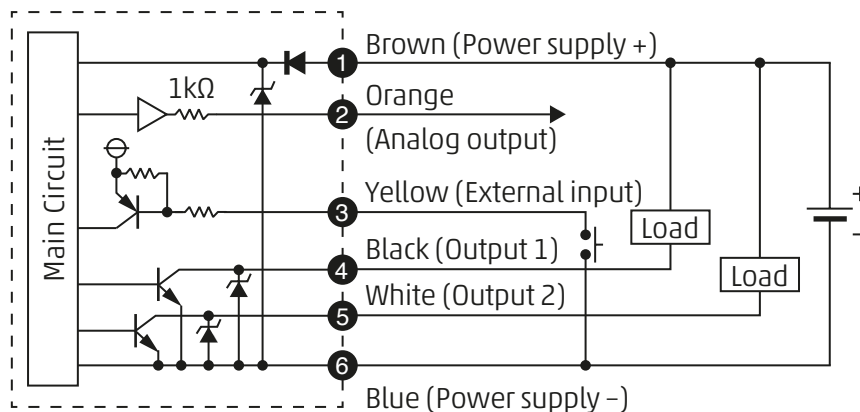

- PNP Output / Analog Current Output / External Input

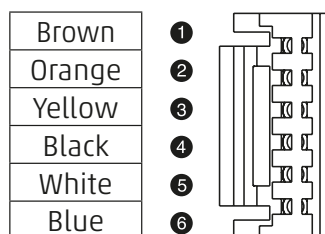
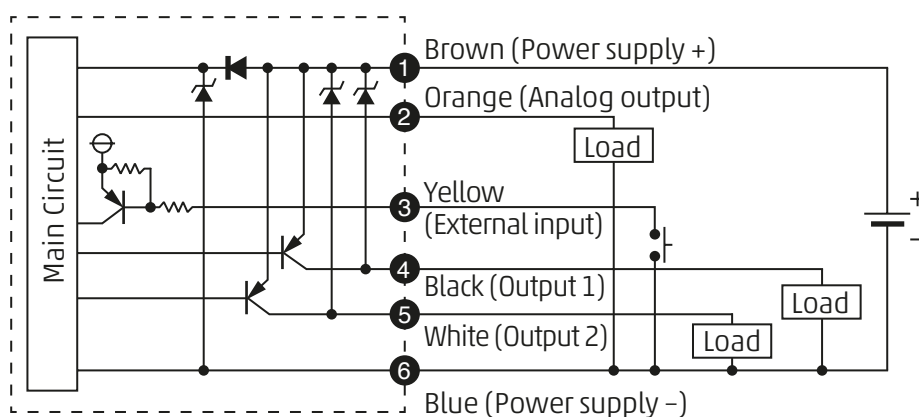

Pin N°	Line color	Content
1	Brown	Power supply (12÷24 VDC)
2	Orange	Analog voltage output: 1 ÷ 5V Analog current output: 4 ÷ 20mA
3	Yellow	External input
4	Black	Output 1 (Max. load current: 125mA)
5	White	Output 2 (Max. load current: 125mA)
6	Blue	0V (GND)

# How to Use

## 3.1 Names and Functions of Individual Parts

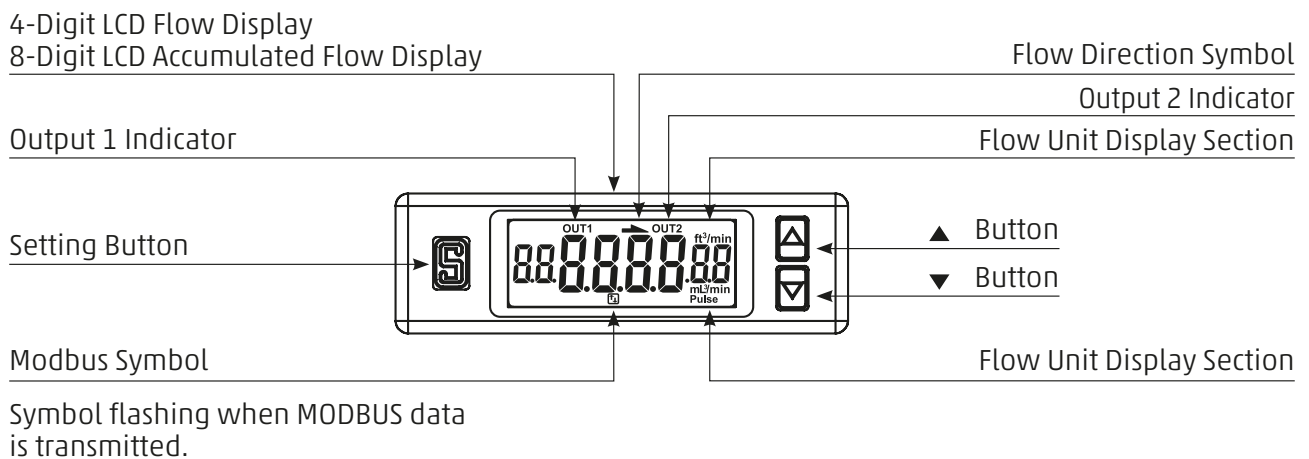
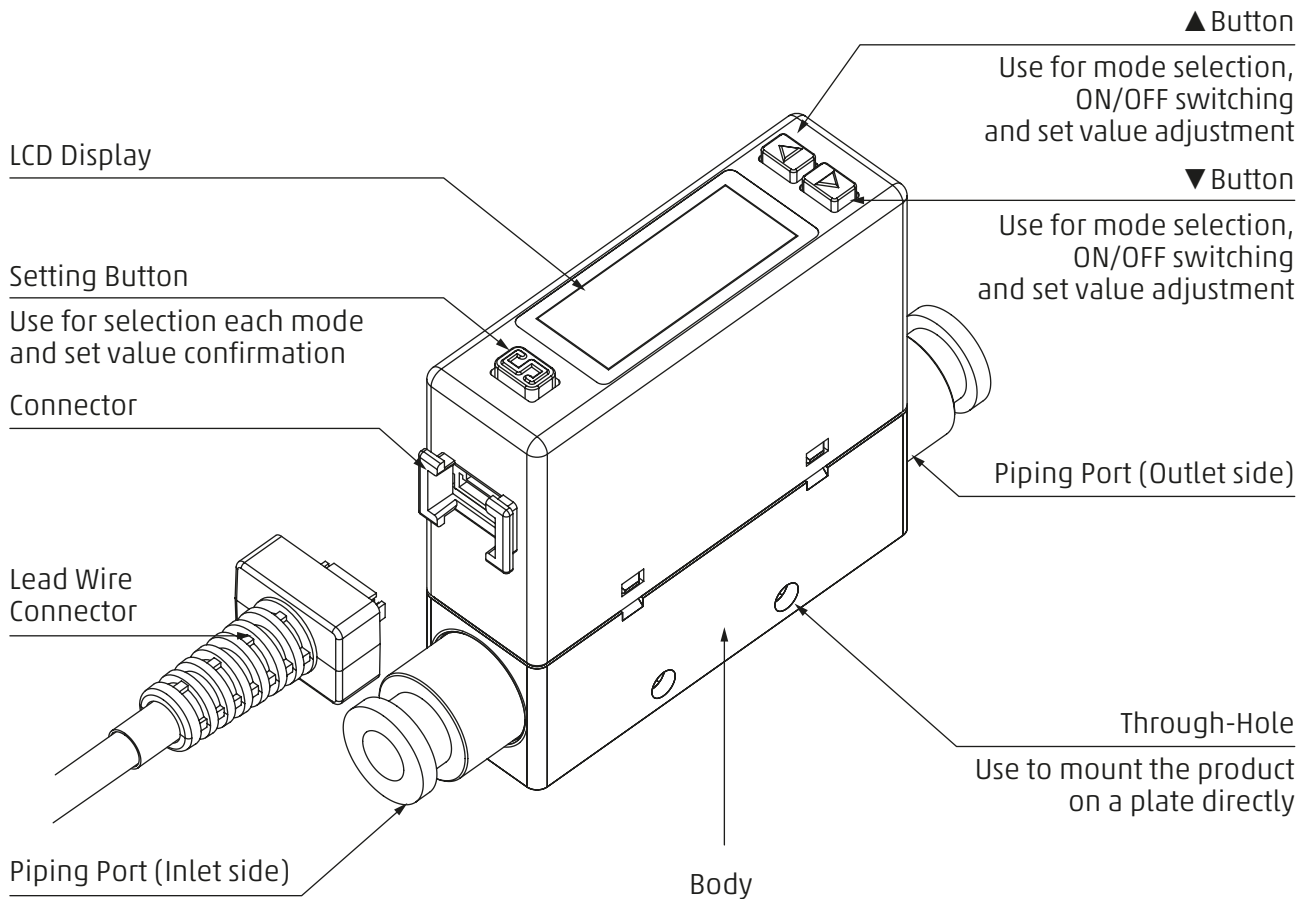

### 3.2 Function Instruction

## 3.2 Function Instruction

### • Function Setting Mode

Function Code	Item	Default setting	Explanation
[F-01]	[OUT1] OUT1 setting		Set Output 1 flow value to switch ON/OFF
	[FL01] OUT1 output mode	HYS	
	[OUT1] OUT1 output type	no	
	[FL-1] OUT1 set value input	50% of maximum measured flow rate 010:500 mL/min 500:25.0 L/min 201:100 L/min	
	[FH-1] OUT1 set value input	60% of maximum measured flow rate 010:600 mL/min 500:30.0 L/min 201:120 L/min	
[F-02]	[OUT2] OUT2 setting		Set Output 2 flow value to switch ON/OFF
	[FL02] OUT2 output mode	HYS	
	[OUT2] OUT2 output type	no	
	[FL-2] OUT2 set value input	50% of maximum measured flow rate 010:500 mL/min 500:25.0 L/min 201:100 L/min	
	[FH-2] OUT2 set value input	60% of maximum measured flow rate 005:300 mL/min 500:30.0 L/min 201:120 L/min	
[F-03]	[ELOR] LCD Display setting		Select back light color and display mode
	[d,SP] LCD Display corresponding to output	OUT1	
	[COL] LCD Display color setting	50G	
[F-04]	[RESP] Response time setting	800(ms)	Select the response time in 50ms, 80ms, 120ms, 200ms, 400ms or 1500ms for analog output
[F-05]	[UPdR] Display refresh time of flow sensor setting	500(ms)	Display refresh cycle can be set in 200ms, 500ms or 1000ms
[F-06]	[Unit] Unit setting		Select the UNIT of flow sensor
	[FL0] Flow unit setting	LPn	
[F-07]	[REFE] Flow reference standard setting	ANr	Select the flow value is shown under standard (ANR) or normal condition (NOR)

### 3.2 Function Instruction

#### • Function Setting Mode

Function Code	Item	Default setting	Explanation
[F-08]	[r0tR] Display rotation	oFF	Set Display Rotation
[F-09]	[EEPr] Accumulated value hold setting	oFF	To save the last accumulated flow value every 2 or 5 minutes
[F-10]	[ d iS] Flow sensor display mode setting		Select to display Instantaneous Flow or Accumulated Flow Mode
	[ dSP] Flow sensor display mode setting	inS	
[F-80]	[SYn] Sync the value of flow analog output and display	oFF	Turn ON to synchronize the value of flow analog output and display
[F-91]	[ELo] Power-Save mode setting	no	Select if turn on power-save mode to reduce power consumption
[F-92]	[ inP] External input setting	r-r	Select for Accumulated flow rate zero clear, Auto-Shift or Auto-Shift zero
[F-93]	[nbus] Modbus RTU setting		Set ID number, baud rate and transmission format
	[ id] ID number setting	1	
	[ rRt] Baud rate setting	96 (9600 Bd)	
	[ For] Transmission format setting	n8 1	
	[ t rR] Communications protocol setting	r t t	
[F-94]	[F inE] Fine adjustment Setting	oFF	The displayed value can be adjusted slightly
[F-95]	[Fout] Forced output function		To force output ON/OFF to test the switch function
	[out 1] Forced output function	oFF	
	[out 2] Forced output function	oFF	
[F-99]	[rESE] Reset to the default setting		Return to the factory default setting
	[ rSE] Reset to the default setting	oFF	

#### • Measurement Mode



Item	Explanation
Flow display	Display instantaneous flow rate
Accumulated flow rate display	Display accumulated flow rate
Instantaneous Flow rate zero setting	The displayed instantaneous flow rate value can be adjusted to "0"
Accumulated flow rate zero clear	The accumulated flow rate can be set to "0"
Peak value display	The maximum pressure or instantaneous flow can be detected when the power is supplied for a period
Bottom value display	The minimum pressure or instantaneous flow can be detected when the power is supplied for a period
Key lock/unlock mode	To prevent errors occurring due to unintentional changes of the set values

### 3.3 Operation Instructions

## 3.3 Operation Instructions

### • Function Selection Mode

At Measurement Mode, press  button for more than 3 sec. to display [F-0 1].

Press  or  button to select other setting functions.

Press  for 3 sec. at Function Setting Mode to return to Measurement Mode.

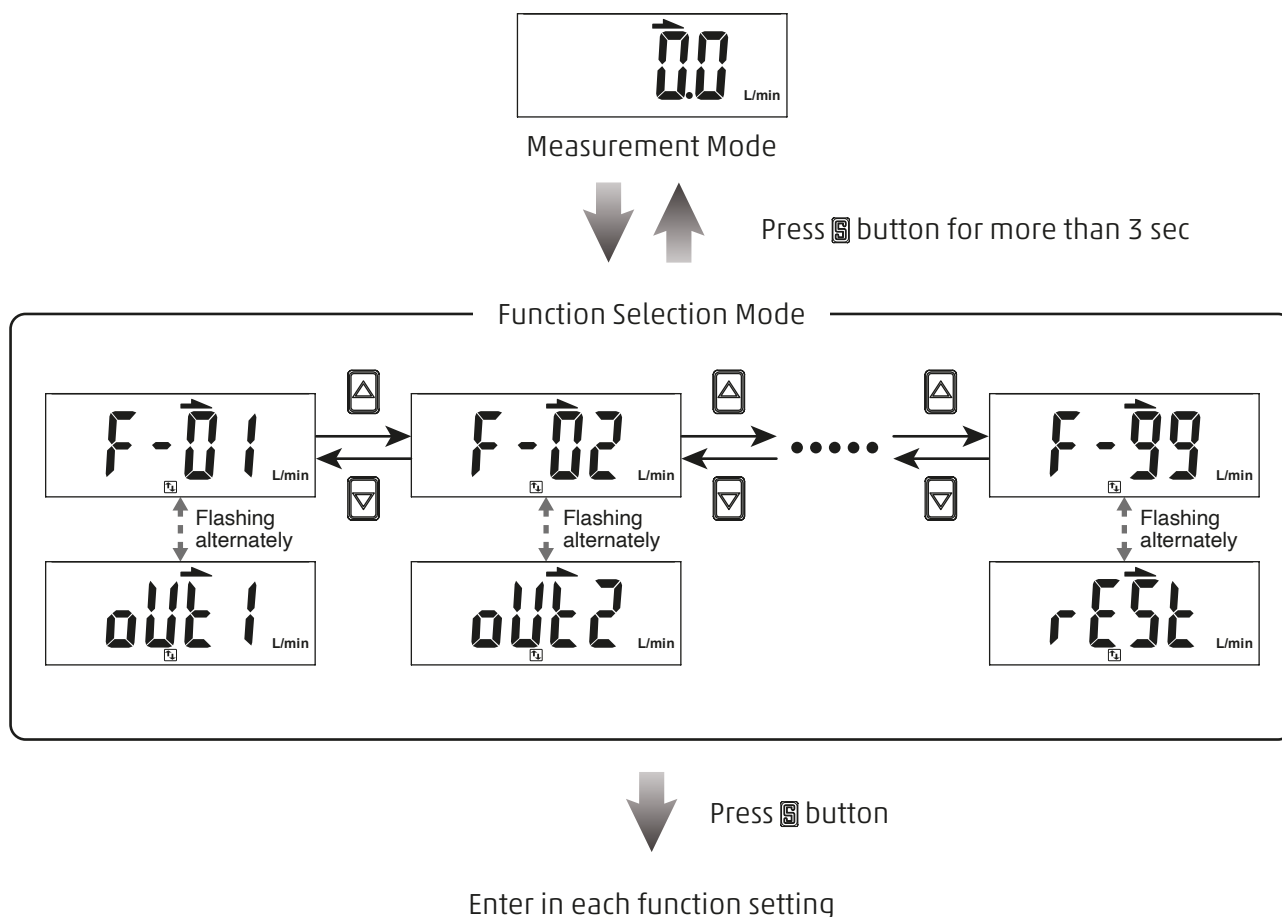

### 3.3 Operation Instructions

#### • [F-01] OUT1 Setting

Press ▲ or ▼ button at Function Setting Mode to display [F-01] [OUT1]

Press  button

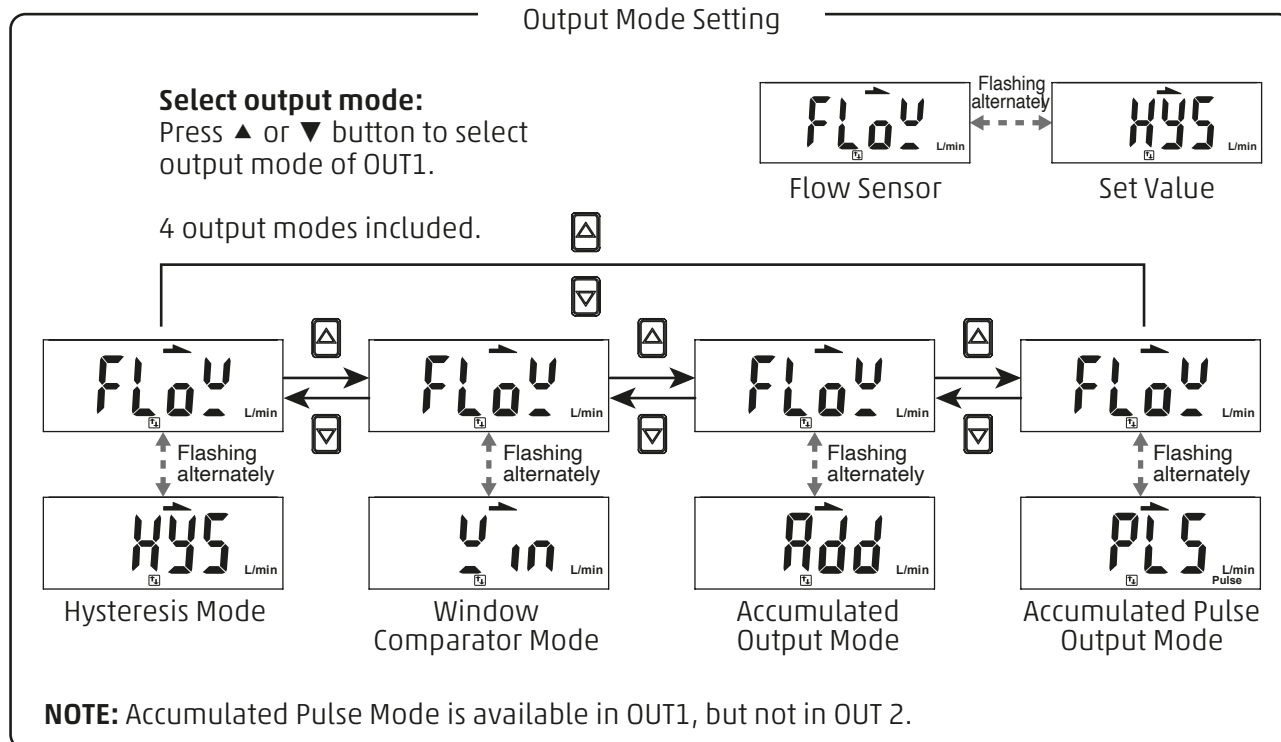

Press  button

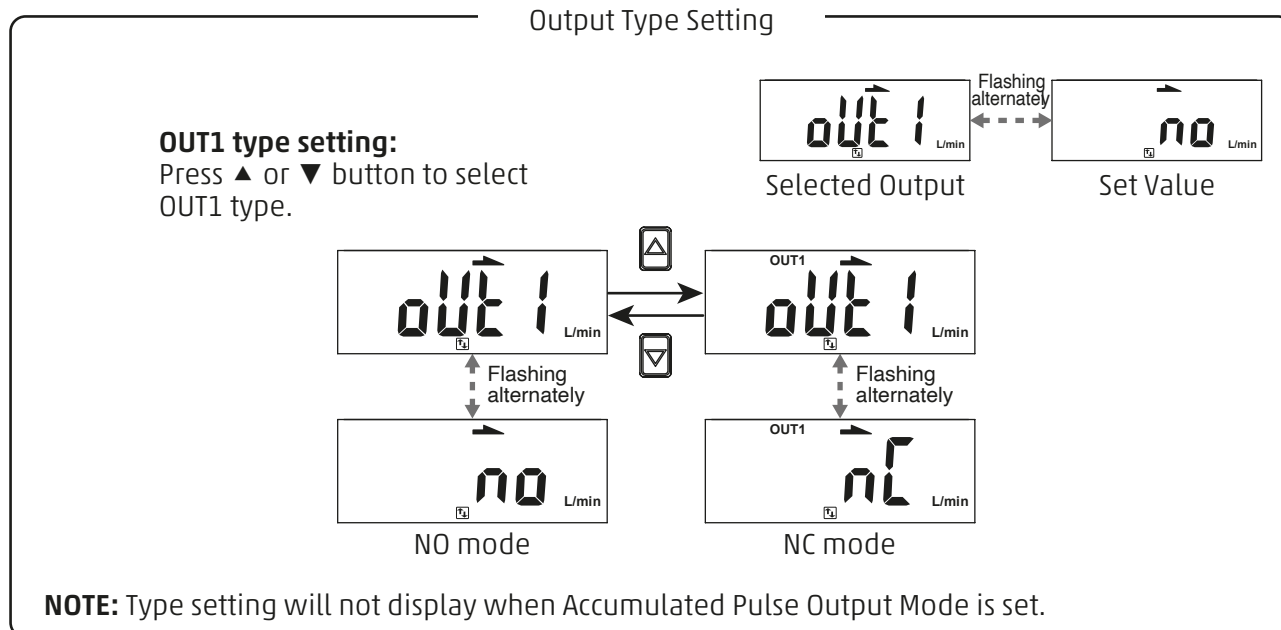



### 3.3 Operation Instructions

Press  button (to be continued)

Set Value Setting

**OUT1 set value setting:**  
Press ▲ or ▼ button to adjust the set value.

Hysteresis Mode [HYS]:[FL - ]  
Window Comparator Mode [Win]:[FL - ]  
Accumulated Output Mode [Add]:[AdL ]

**NOTE:** Set value setting will not display when Accumulated Pulse Output is set.



Selected Mode                      Set Value

Press  button

Set Value Setting

**OUT1 set value setting:**  
Press ▲ or ▼ button to adjust the set value.

Hysteresis Mode [HYS]:[FH- ]  
Window Comparator Mode [Win]:[FH- ]  
Accumulated Output Mode [Add]:[AdH ]

**NOTE:** Set value setting will not display when Accumulated Pulse Output is set.



Selected Mode                      Set Value

Press  button

Fixed Hysteresis Setting

**Fixed hysteresis setting:**  
Press ▲ or ▼ button to adjust fixed hysteresis value.

**NOTE:** Fixed hysteresis setting is available when selecting Window Comparator Mode.



Fixed Hysteresis Mode                      Set Value

Press  button to return to Function Selection Mode

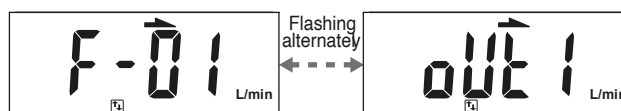

### 3.3 Operation Instructions

- [F-02] OUT2 Setting

Press ▲ or ▼ button at Function Setting Mode to display [F-02] [OUT2]



#### Output Mode Setting

**Select output mode:**

Press ▲ or ▼ button to select output mode of OUT2.

3 output modes included.

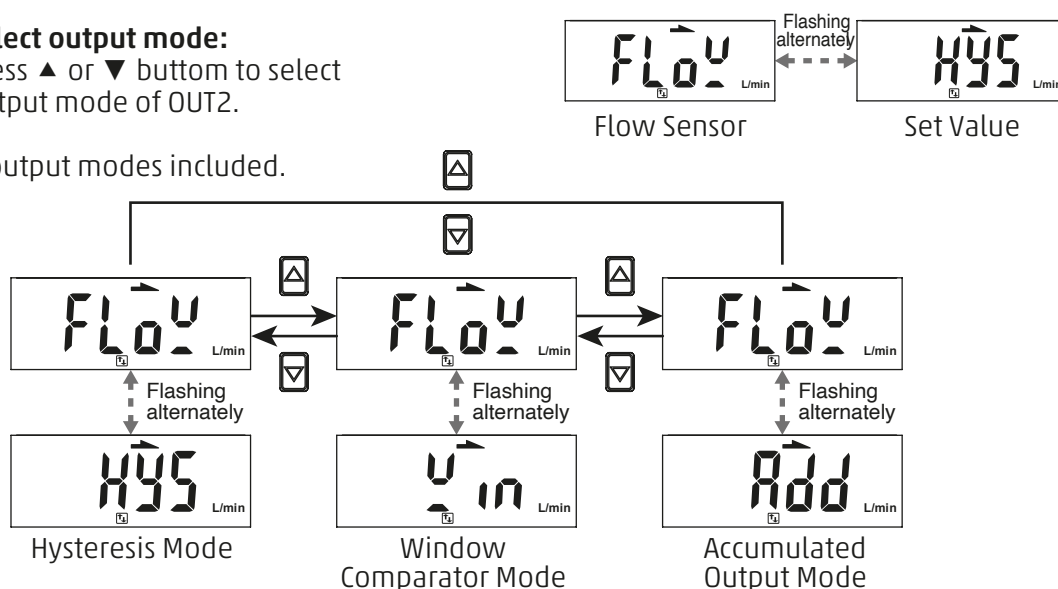

**NOTE:** Accumulated Pulse Mode is available in OUT1, but not in OUT 2.



#### Output Type Setting

**OUT2 type setting:**

Press ▲ or ▼ button to select OUT2 type.

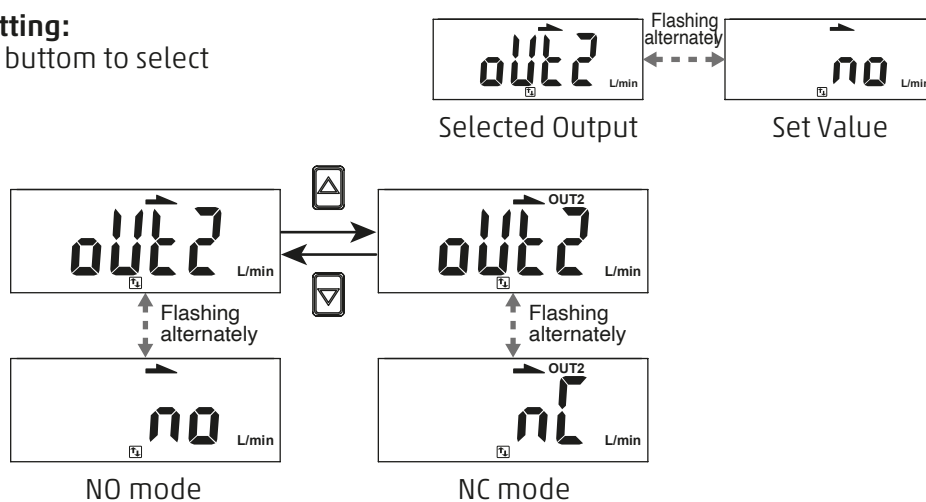

### 3.3 Operation Instructions

Press  button (to be continued)

#### Set Value Setting

**OUT2 set value setting:**  
Press ▲ or ▼ button to adjust the set value.

Hysteresis Mode [HYS]:[FL-2]  
Window Comparator Mode [Win]:[FL-2]  
Accumulated Output Mode [Add]:[AdL2]

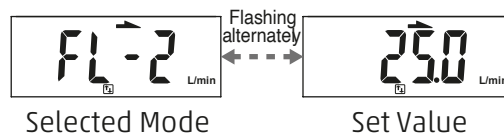

Press  button

#### Set Value Setting

**OUT2 set value setting:**  
Press ▲ or ▼ button to adjust the set value.

Hysteresis Mode [HYS]:[FH-2]  
Window Comparator Mode [Win]:[FH-2]  
Accumulated Output Mode [Add]:[AdH2]

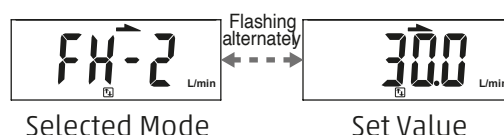

Press  button

#### Fixed Hysteresis Setting

**Fixed hysteresis setting:**  
Press ▲ or ▼ button to adjust fixed hysteresis value.

**NOTE:** Fixed hysteresis setting is available when selecting Window Comparator Mode.

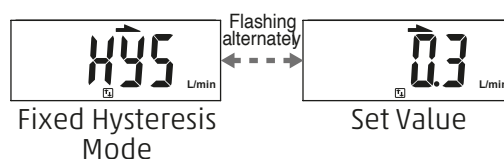

Press  button to return to Function Selection Mode

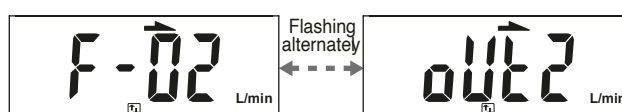

### 3.3 Operation Instructions

#### Normal Open Mode

##### Hysteresis Mode

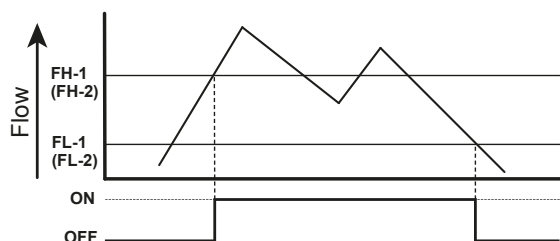

#### Normal Close Mode

##### Hysteresis Mode

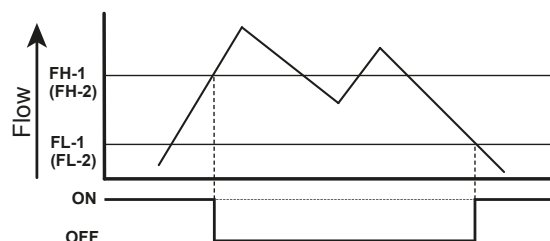

##### Window Comparator Mode

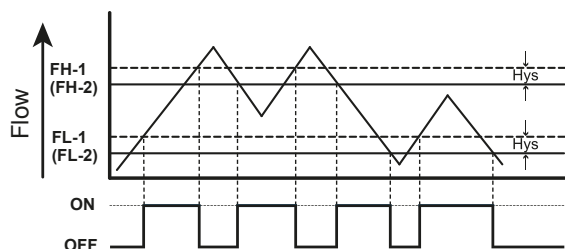

##### Window Comparator Mode

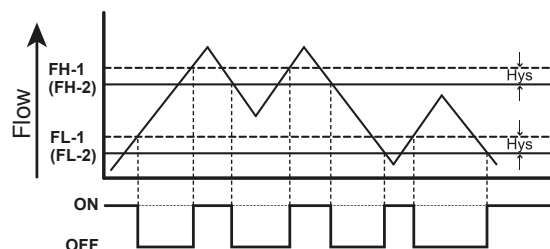

##### Accumulated Output Mode

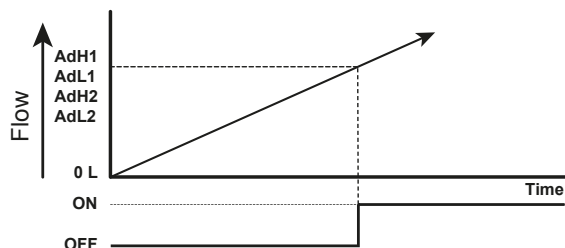

##### Accumulated Output Mode

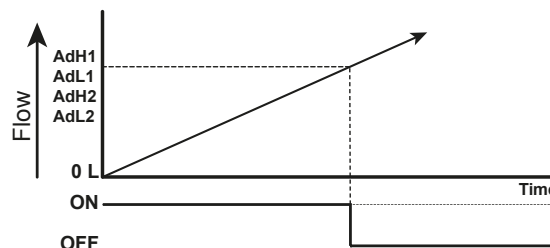

##### Accumulated Pulse Output Mode

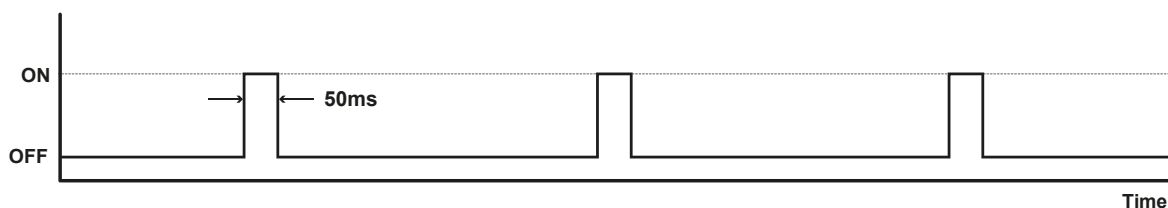

<b>Flow Range</b>	1L	50L	200L
<b>Pulse Output Rate</b>	10mL	0.5L	2L

#### NOTE:

1. In case hysteresis is set at less than or equal to 2 digits, switch output may chatter if input detected fluctuates near the set point.
2. When using window comparator mode, the difference between two set points must be greater than the fixed hysteresis, otherwise will cause the switch output to malfunction.

### 3.3 Operation Instructions

#### • [F-03] LCD Display Color Setting

4 LCD Display Color Modes of output value selection.

Press ▲ or ▼ button at Function Setting Mode to display [F-03] [CLor]

Press  button

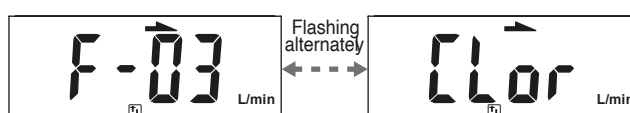
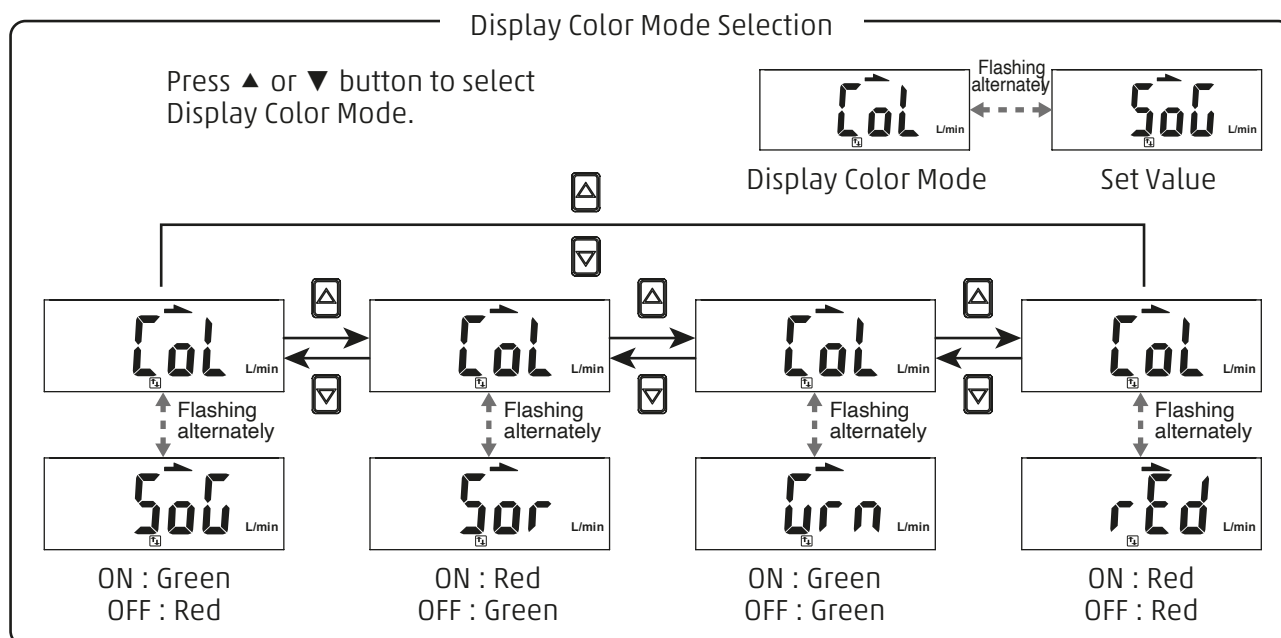
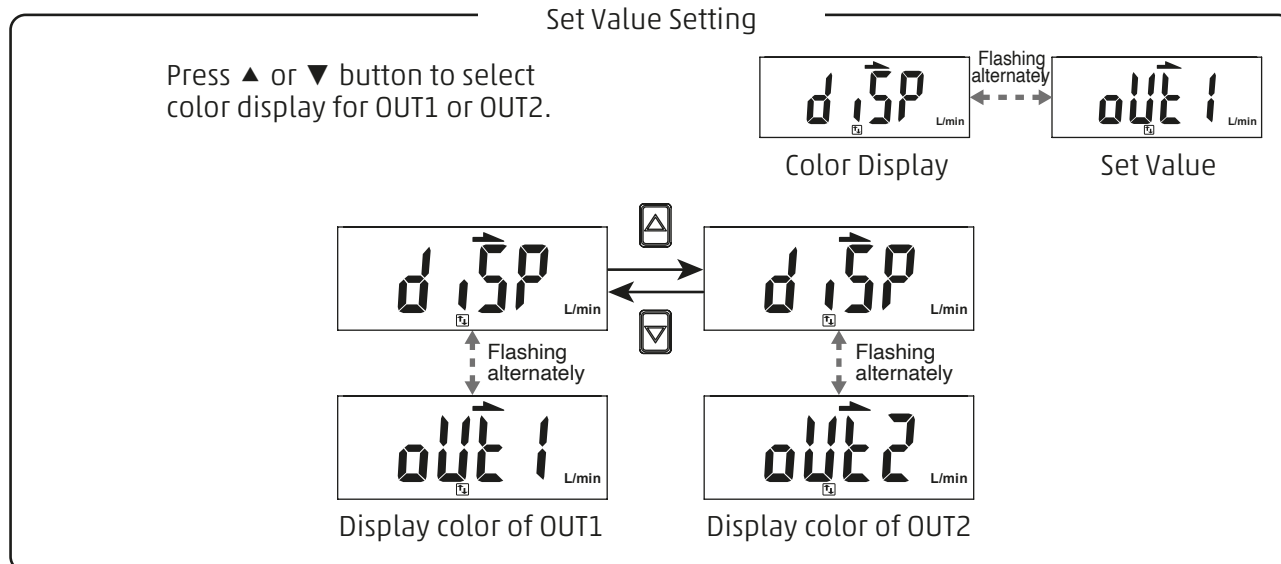

### 3.3 Operation Instructions

#### • [F-04] Response Time Setting

Select proper response time to avoid switch output chattering.

Press ▲ or ▼ button at Function Selection Mode to display [F-04] [rESP].

Press  button

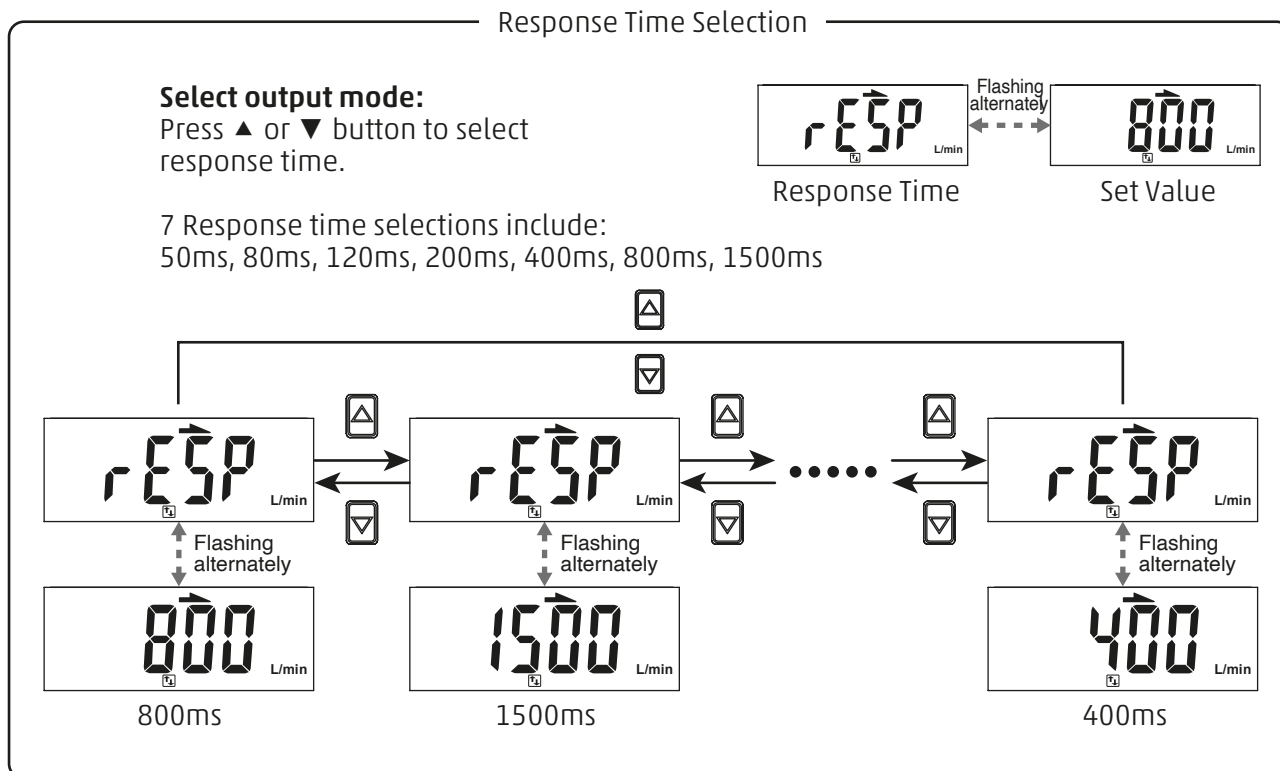

Press  button to return to Function Selection Mode



### 3.3 Operation Instructions

#### • [F-05] Display Refresh Time Setting

Select the proper display refresh time to reduce frequently changing value.

Press ▲ or ▼ button at Function Selection Mode to display [F-05] [UPdR].

↓ Press  button

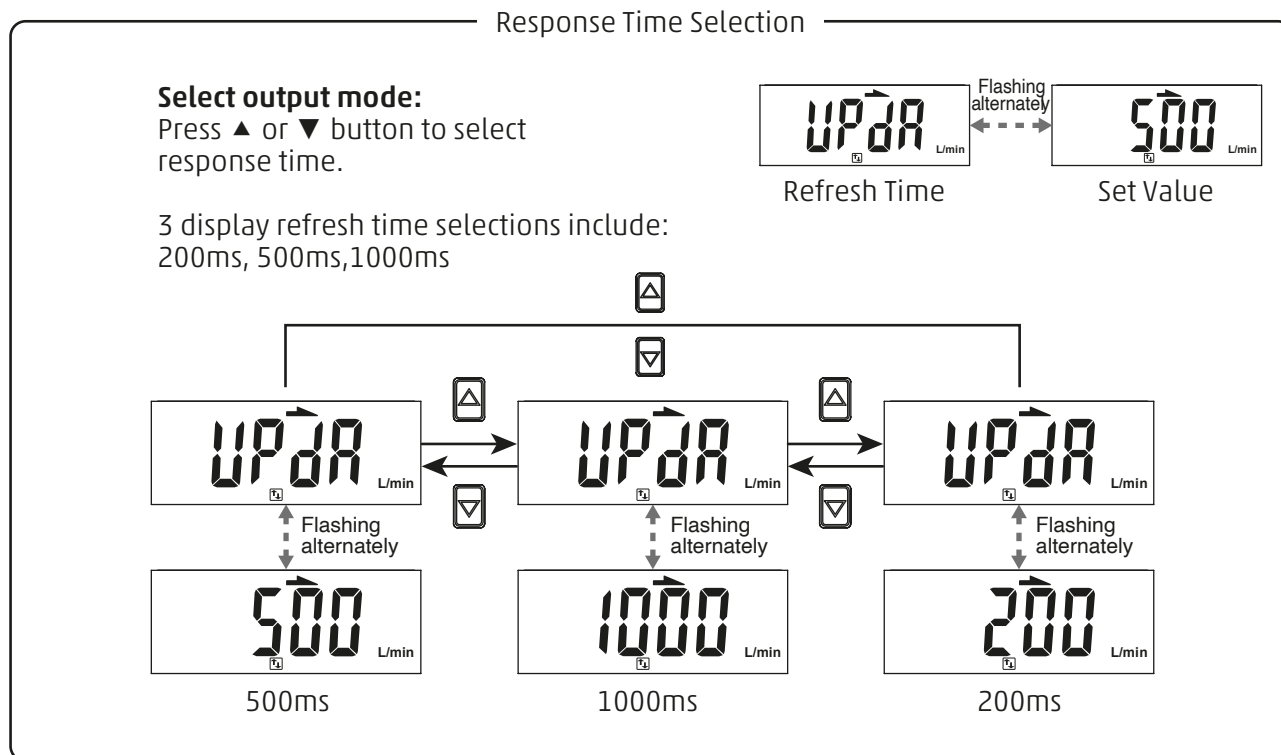

↓ Press  button to return to Function Selection Mode



### 3.3 Operation Instructions

#### • [F-06] Unit Setting

Select the flow unit of the sensor.

Press ▲ or ▼ button at Function Selection Mode to display [F-06] [Unit].

↓  
Press  button

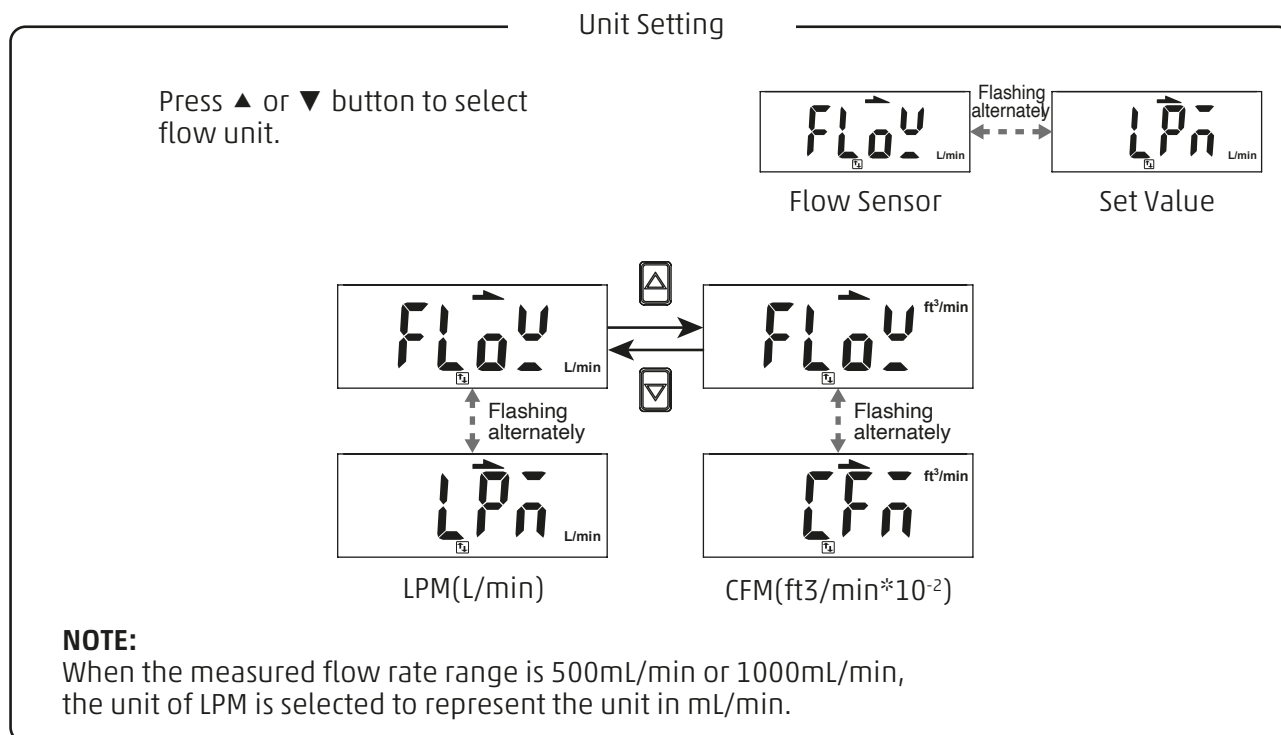

↓  
Press  button to return to Function Selection Mode

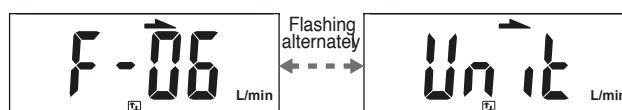



### 3.3 Operation Instructions

#### • [F-07] Flow Reference Standard Setting

Select the flow value is shown under standard or normal condition.

Press ▲ or ▼ button at Function Selection Mode to display [F-07] [rEFE].

↓  
Press  button

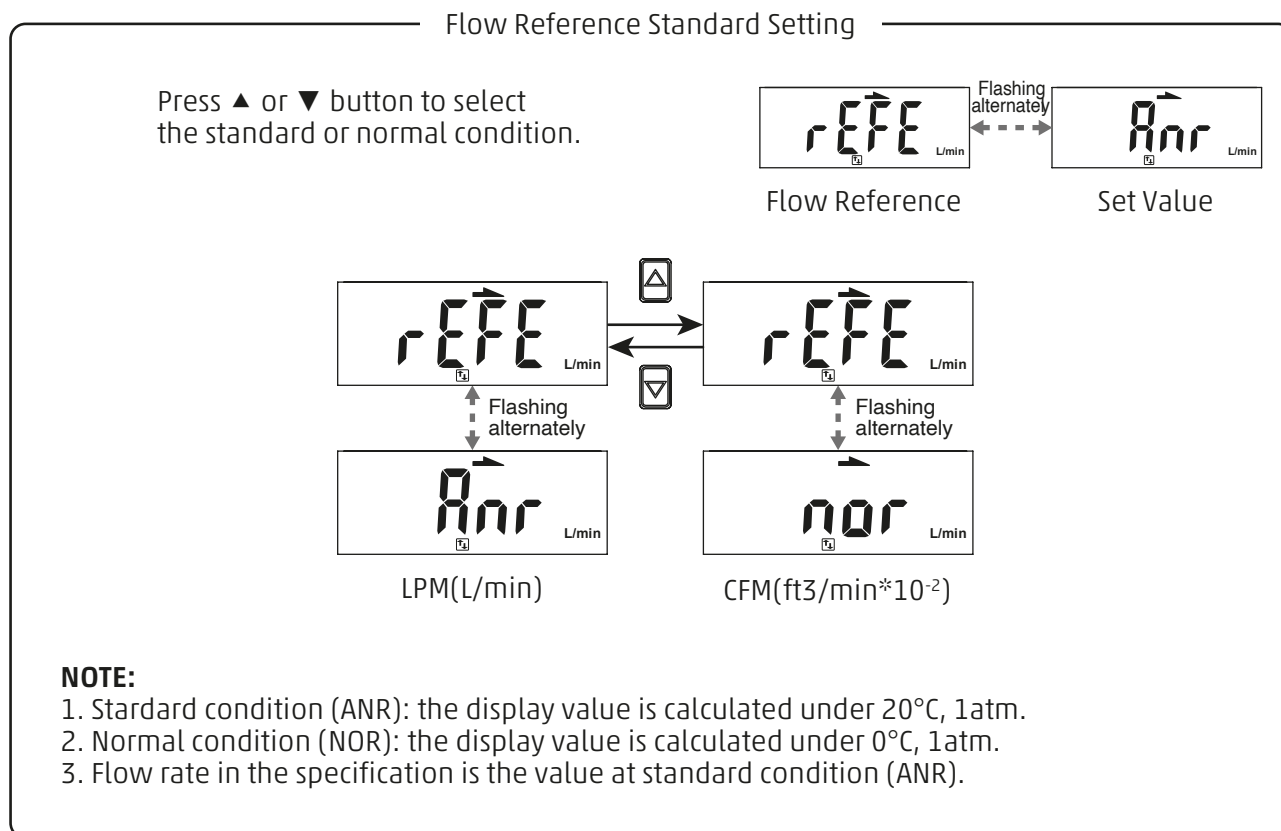

↓  
Press  button to return to Function Selection Mode

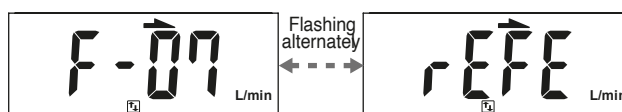

### 3.3 Operation Instructions

- [F-08] Display rotation

Rotate the display vertically.

Press ▲ or ▼ button at Function Selection Mode to display [F-08] [rotR].

Press  button

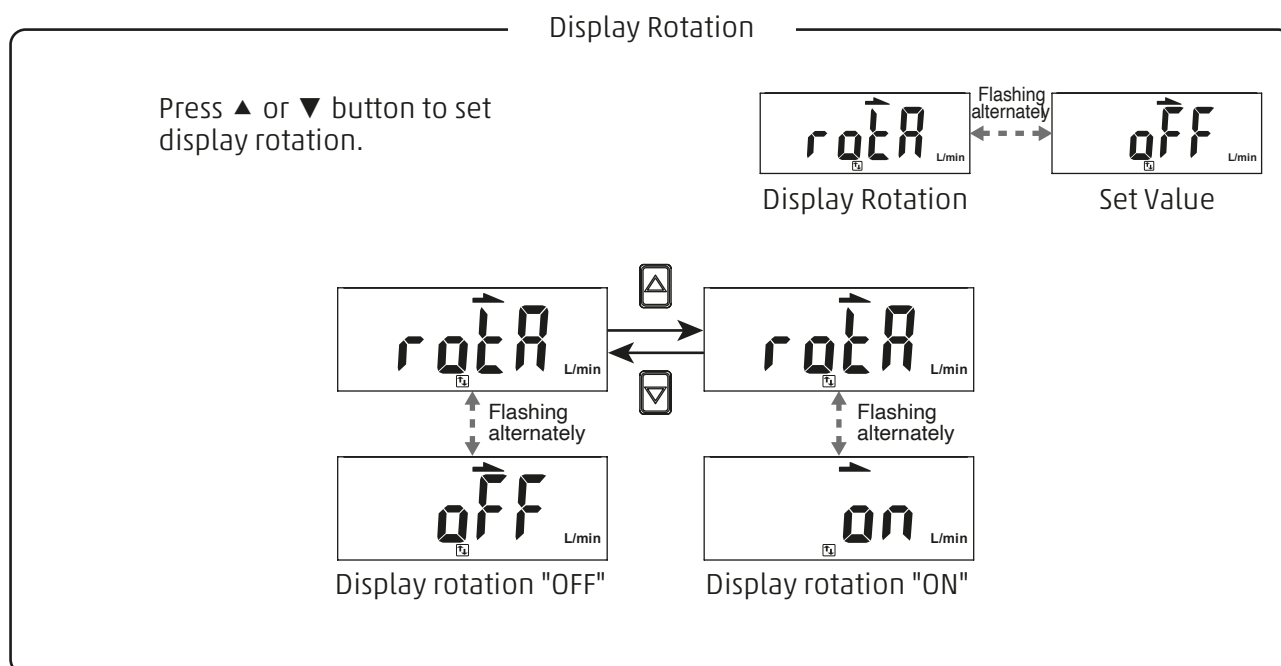

Press  button to return to Function Selection Mode

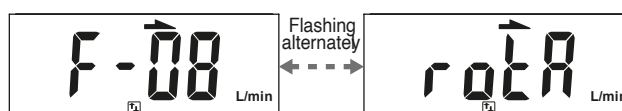

### 3.3 Operation Instructions

#### • [F-09] Accumulated Value Hold Setting

The default setting is "OFF", the accumulated flow value is zeroed when the power supply is turned off. Select this function to keep accumulated flow value to be stored in permanent memory and reload the recent saved accumulated value after power supply turns on.

Press ▲ or ▼ button at Function Selection Mode to display [F-09] [EEP<sub>r</sub>].

Press button

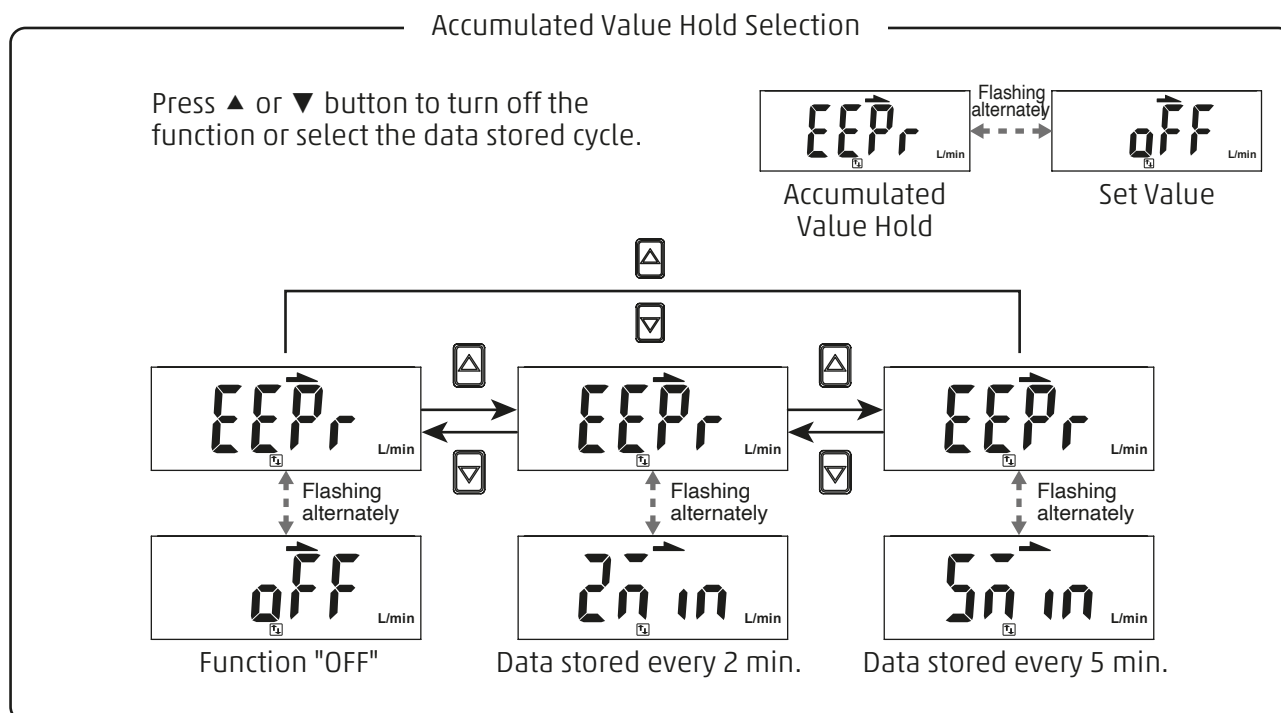

#### NOTE:

The maximum writable limit of the memory device is 1 million cycles. If the sensor is operated 24 hours per day, the durability is calculated as below:

- 5 minutes x 1 million cycles = 5 million minutes = 9.5 years
- 2 minutes x 1 million cycles = 2 million minutes = 3.8 years

### 3.3 Operation Instructions

#### • [F-010] Flow Sensor Display Mode Setting

Select to display Instantaneous Flow or Accumulated Flow Mode.

Press ▲ or ▼ button at Function Selection Mode to display [F-10] [d.5].

Press  button

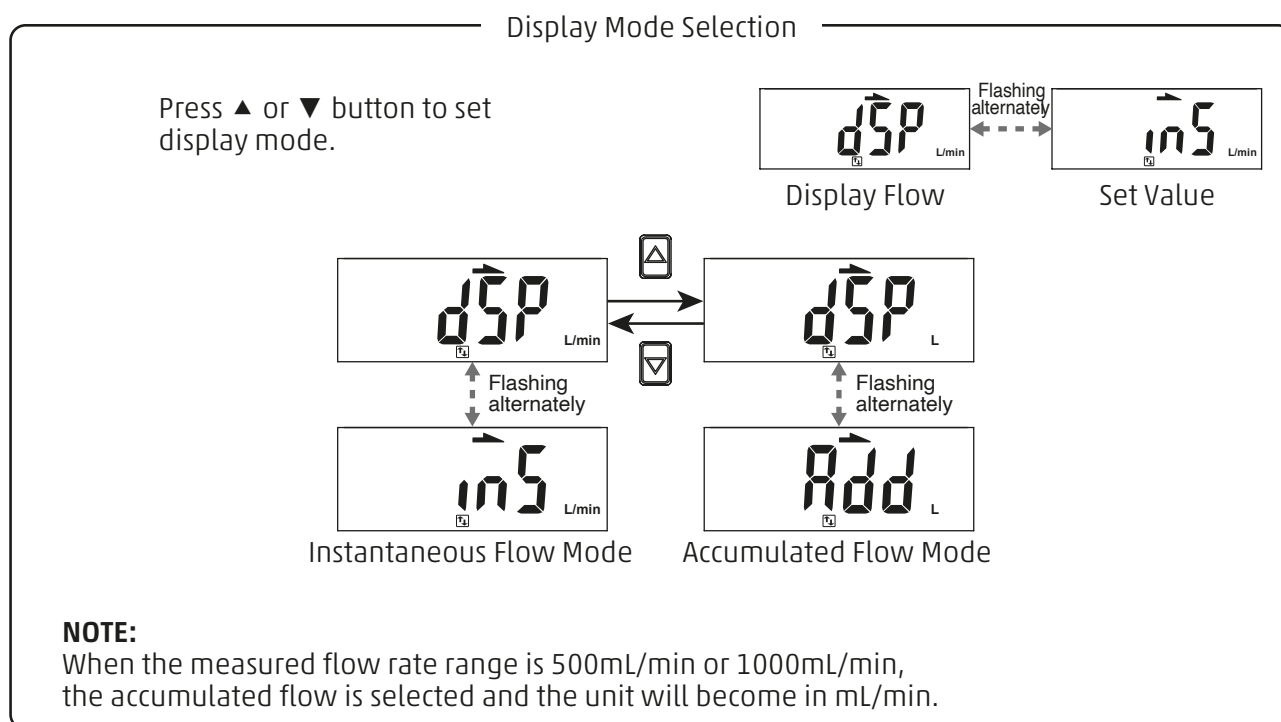

Press  button to return to Function Selection Mode

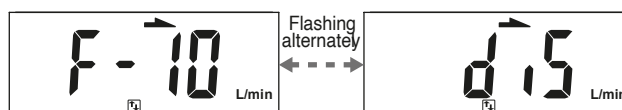

### 3.3 Operation Instructions

- [F-080] Sync the value of flow analog output and display

Turn ON to synchronize the value of flow analog output and display.

Press ▲ or ▼ button at Function Selection Mode to display [F-80] [59n].

Press  button

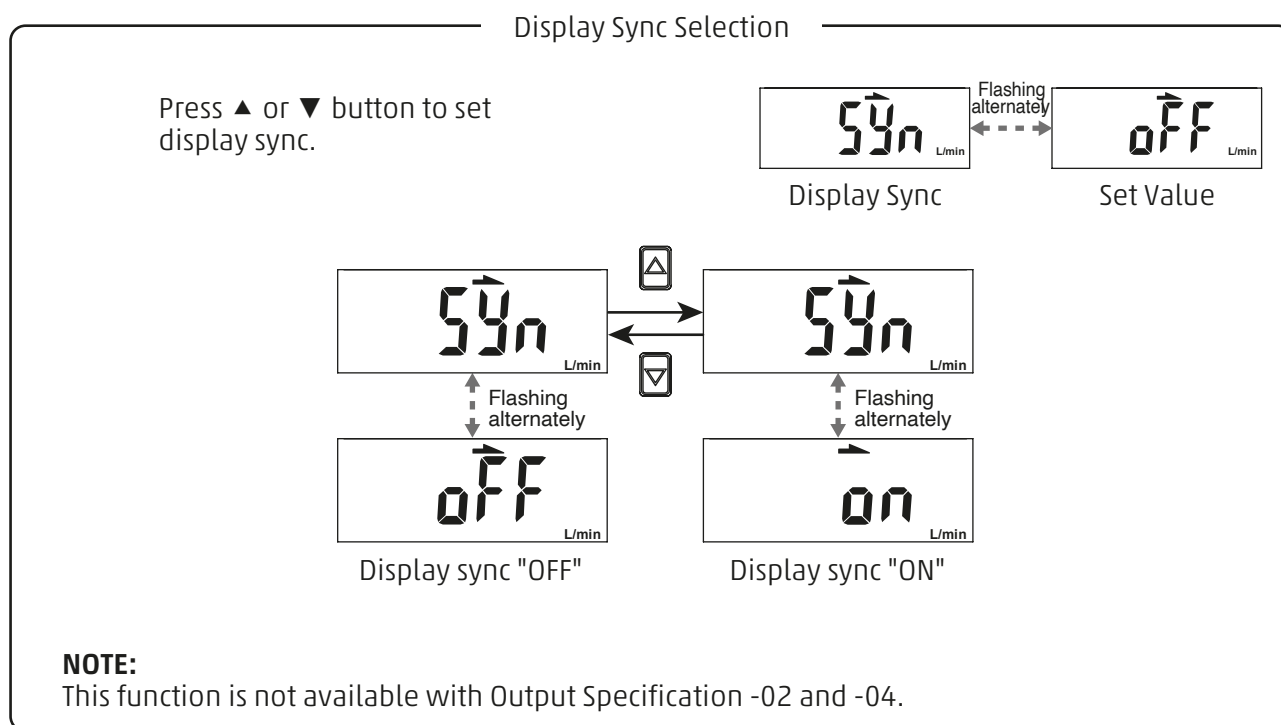

Press  button to return to Function Selection Mode

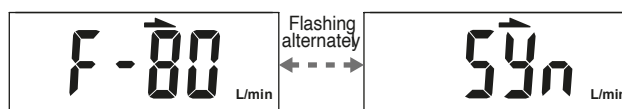

### 3.3 Operation Instructions

#### • [F-91] Power-Save Mode Setting

Select Power-Save Mode at Measurement Mode.

During the Power-Save Mode, the main display will turned off if no buttons is pressed in 30 sec., press any keys to leave the Power-Save Mode.

Press ▲ or ▼ button at Function Selection Mode to display [F-91] [ELO].

Press  button

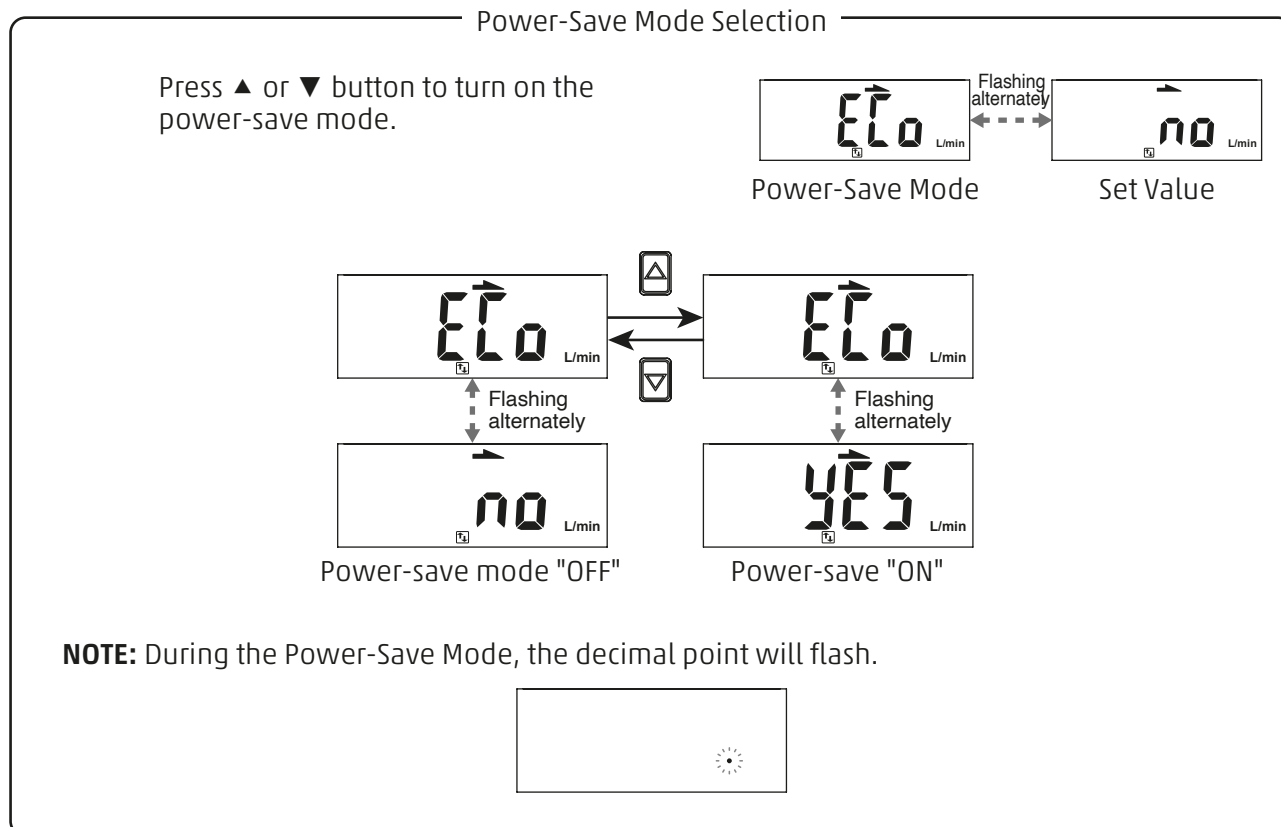

Press  button to return to Function Selection Mode

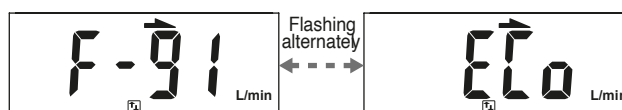

### 3.3 Operation Instructions

#### • [F-092] External Input Setting

Accumulated flow external reset: The accumulated flow value will reset to "0" when an external input signal is applied.

Auto-shift: The instantaneous flow rate will regard as the standard when the external input signal is applied. The switch output function operates relative to its change.

Auto-shift zero: The instantaneous flow rate is reset to zero to regard as standard when the external input signal is applied. The switch output function operates relative to its change.

This function is only for output 1 corresponding to flow sensor action point. When external signal is input, please connect the input wire to GND for 30 ms or more.

Press ▲ or ▼ button at Function Selection Mode to display [F-92] [inP].

Press button

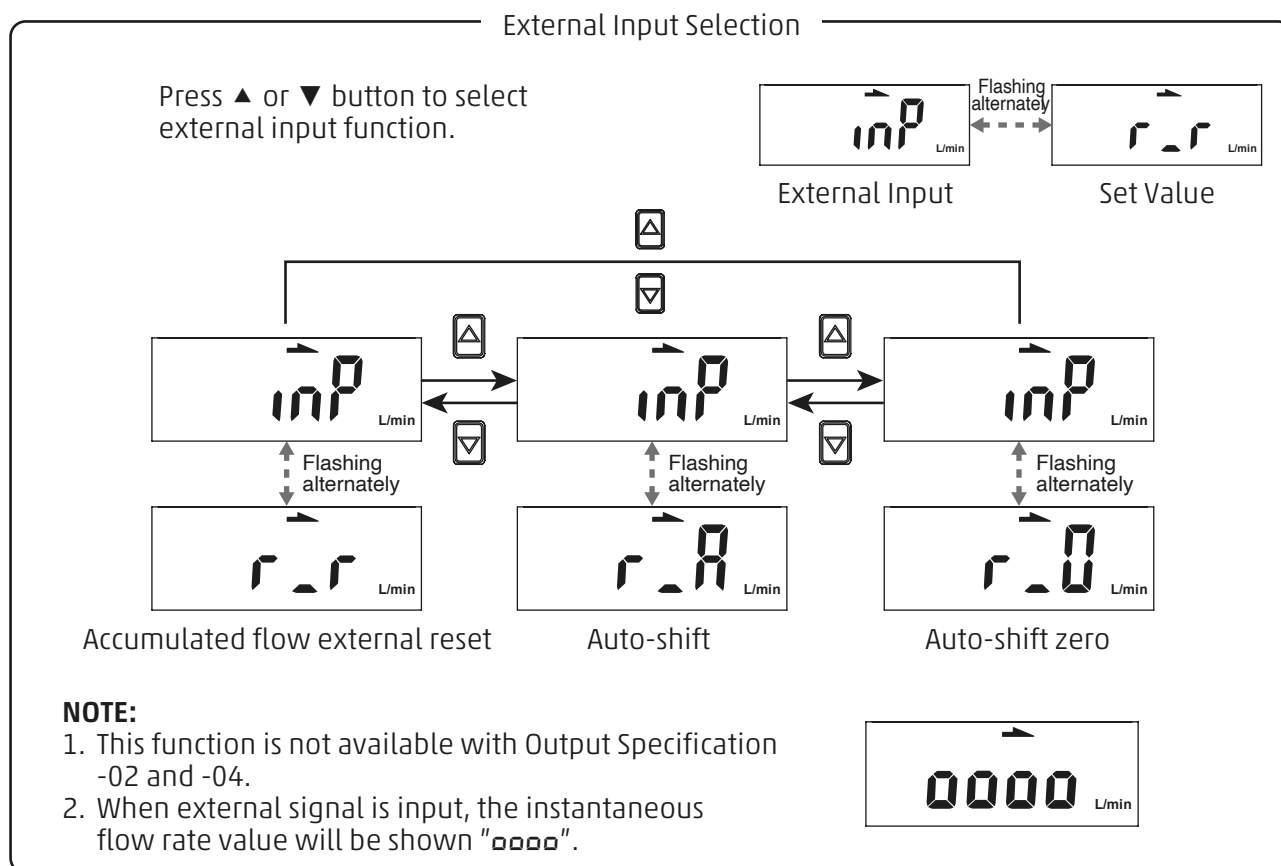

Press button to return to Function Selection Mode

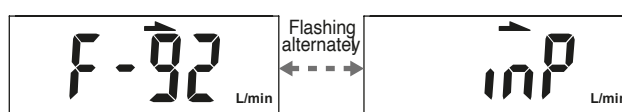

### 3.3 Operation Instructions

#### • [F-93] Modbus RTU Setting

MODBUS transmission protocol can be set according to user requirements.

Press ▲ or ▼ button at Function Selection Mode to display [F-93] [MODBUS].

Press  button

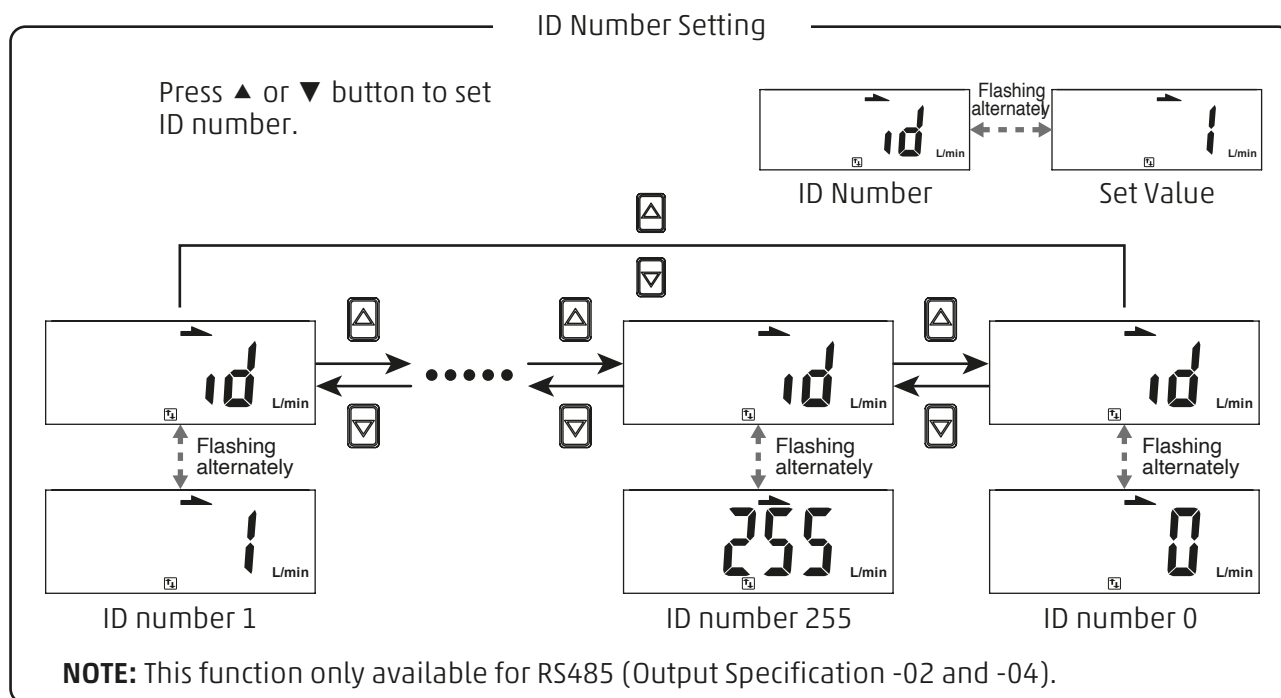

Press  button

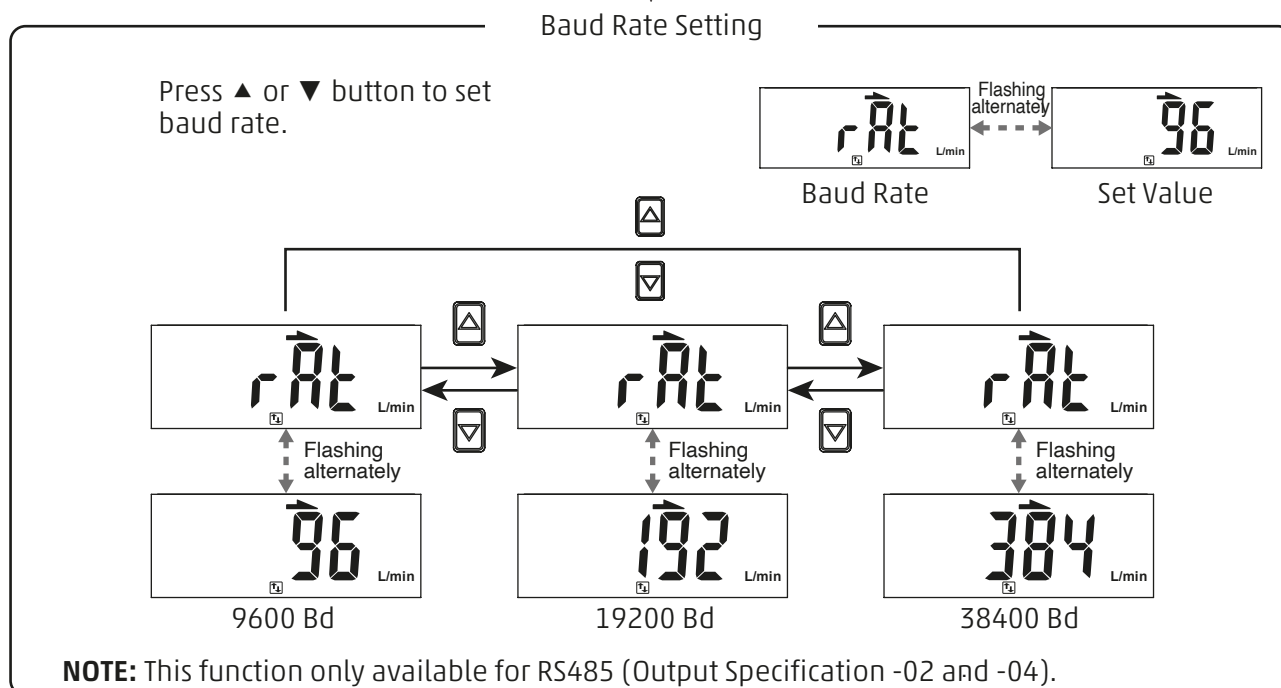



Press button (to be continued)

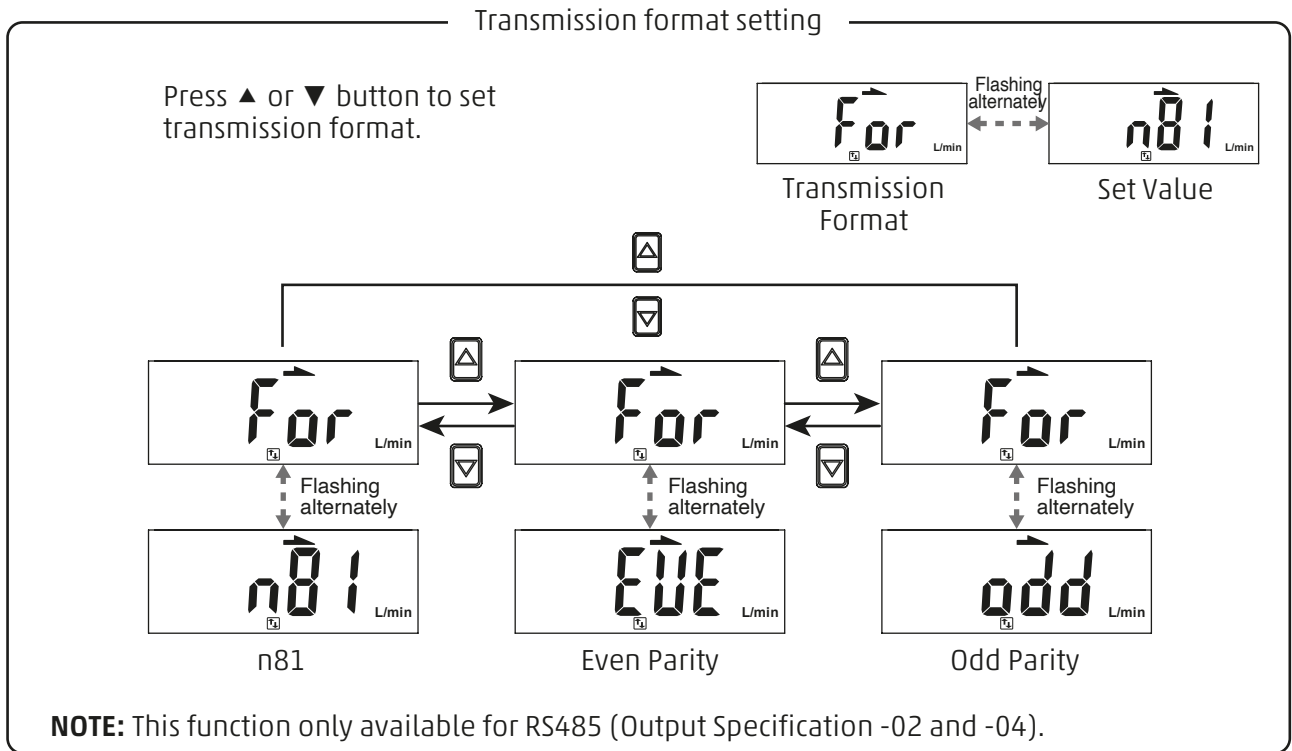

Press button

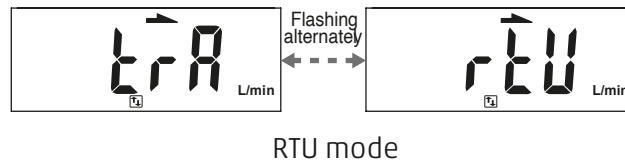

Press button to return to Function Selection Mode

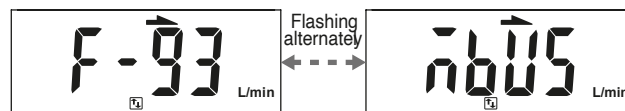

### 3.3 Operation Instructions

#### • [F-94] Fine Adjustment Setting

This function is to fine adjust flow and pressure display values.  
Display values can be calibrated to within  $\pm 2.5\%$  R.D.

Press  $\blacktriangle$  or  $\blacktriangledown$  button at Function Selection Mode to display [F-94] [FINE].

Press  button

Fine Adjustment Setting



Press  $\blacktriangle$  or  $\blacktriangledown$  button to select fine adjustment OFF or to set fine adjustment instantaneous flow rate value or pressure value.



Fine Adjustment Set Value



Fine adjustment function "OFF"

  

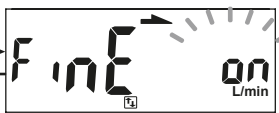

Fine adjustment function "ON"

Fine Adjustment Setting

Press  $\blacktriangle$  or  $\blacktriangledown$  button to set fine adjustment value.

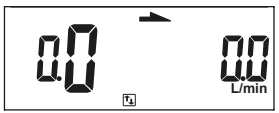

Set Value      Instantaneous flow value

Flashing alternately

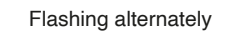



Fine adjustment setting      Instantaneous flow

Press  button to return to Function Selection Mode

Return to the measurement mode

### 3.3 Operation Instructions

- [F-95] Forced Output Function

To force output ON/OFF to test the switch function.

Press ▲ or ▼ button at Function Selection Mode to display [F-95] [FOUT].

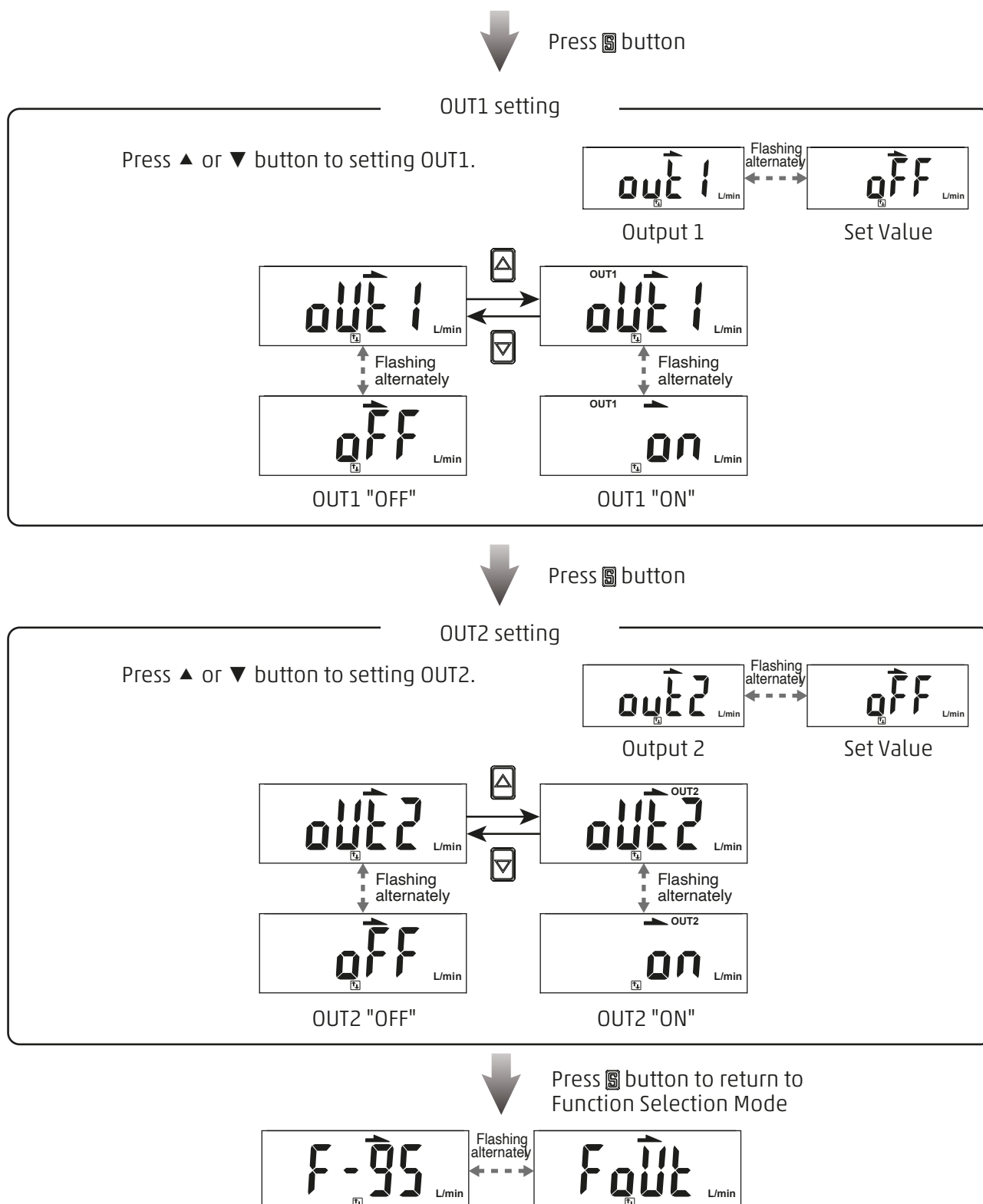

### 3.3 Operation Instructions

- [F-99] Reset to the Default Setting

The factory default settings can be restored.

Press ▲ or ▼ button at Function Selection Mode to display [F-99] [rESt].

Press  button

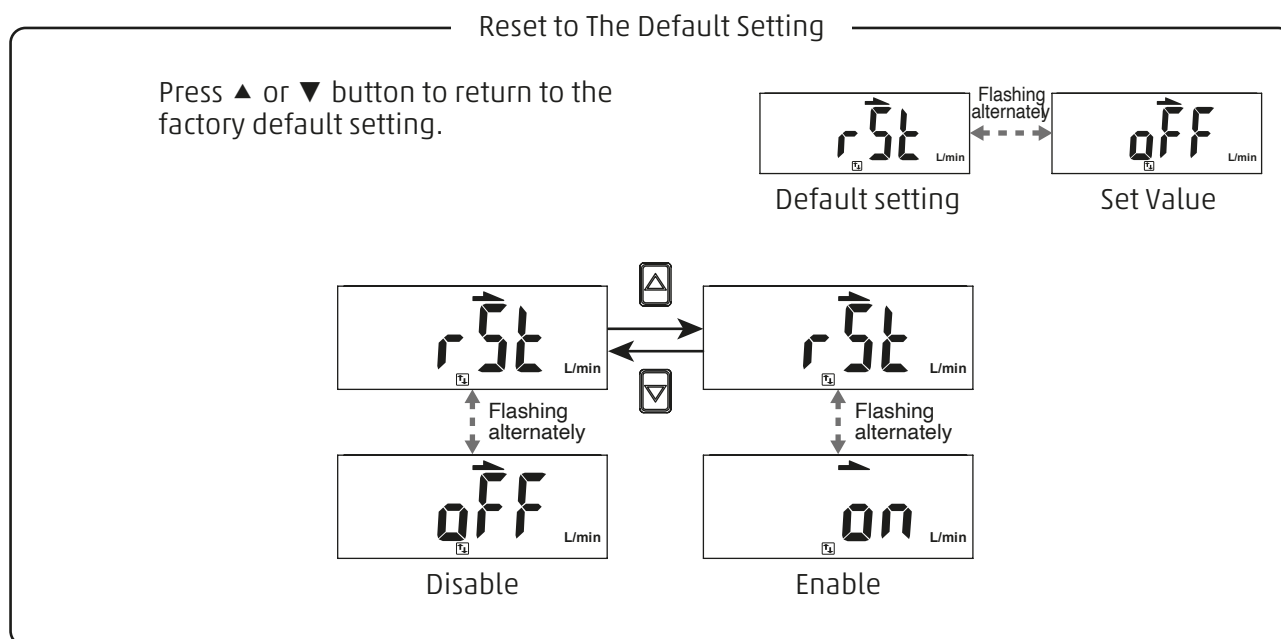

Press  button to return to Function Selection Mode

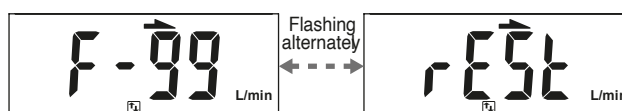



### 3.3 Operation Instructions

#### • Instantaneous Flow Zero Adjustment Function

The displayed value can be adjusted to "0" when the measured flow is within  $\pm 5\%$  F.S. of the zero point at the time of shipment from the factory.

#### < Operation >

Press  and  button simultaneously over 3 sec. at the measurement mode (not Accumulated flow value display mode) until display [00]. And release holding the button to return measurement mode.

Measurement mode



Press  and  button simultaneously over 3 sec.

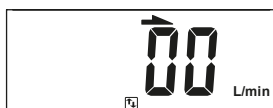

To release holding the button to return measurement mode.

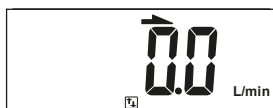



Instantaneous flow value return zero.

### 3.3 Operation Instructions

- **Reset Accumulated Flow Function**

Accumulate flow value return to zero.

**< Operation >**

Press  and  button simultaneously over 3 sec. at the measurement mode (Accumulated flow value mode) until display zero. And release holding the button to return measurement mode.

Measurement mode

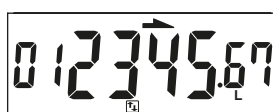

Press  and  button simultaneously over 3 sec.

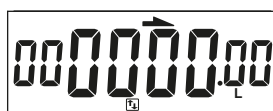

Accumulated value display zero.  
To release holding the button to return measurement mode.

### 3.3 Operation Instructions

#### • Peak Value Display

The maximum pressure and instantaneous flow, from when the power was supplied to this moment, is detected and updated.

#### < Operation >

Press ▲ button over 3 sec. at the measurement mode.  
 The maximum value will be displayed flashing, and is held.  
 Press ⏻ button return to the measurement mode.

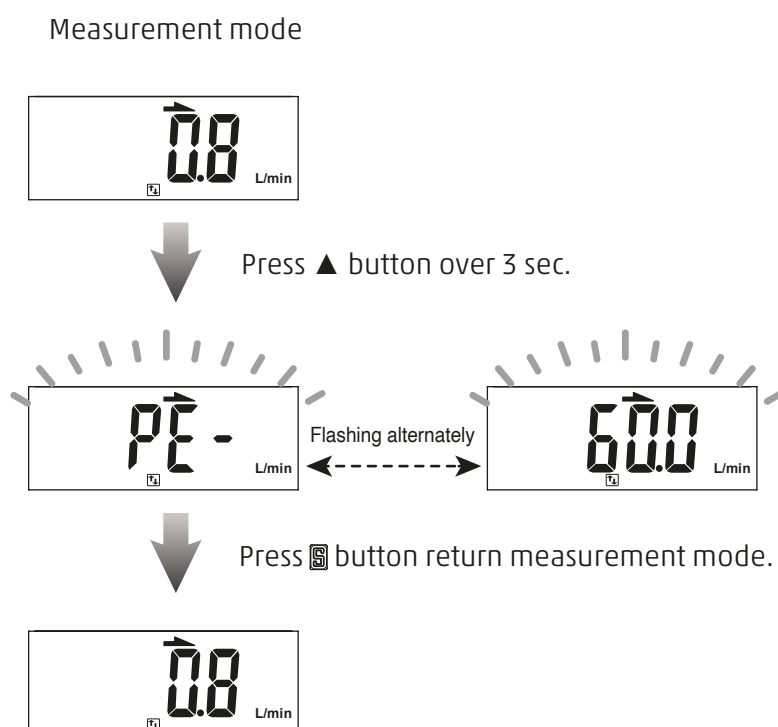

### 3.3 Operation Instructions

#### • Bottom Value Display

The minimum pressure and instantaneous flow, from when the power was supplied to this moment, is detected and updated.

#### < Operation >

Press ▼ button over 3 sec. at the measurement mode.  
 The minimum value will be displayed flashing, and is held.  
 Press [S] button return to the measurement mode.

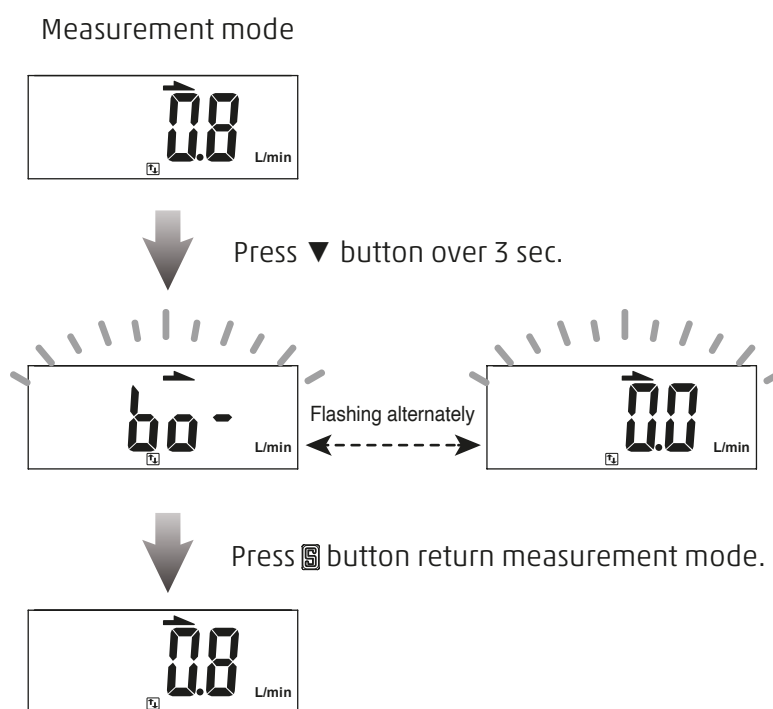



### 3.3 Operation Instructions

#### • Key Lock / Unlock Mode

To prevent errors occurring due to unintentional changes of the set values. If a button operation is performed while the key lock setting is ON, [LoC] [On] is displayed for 1 sec.



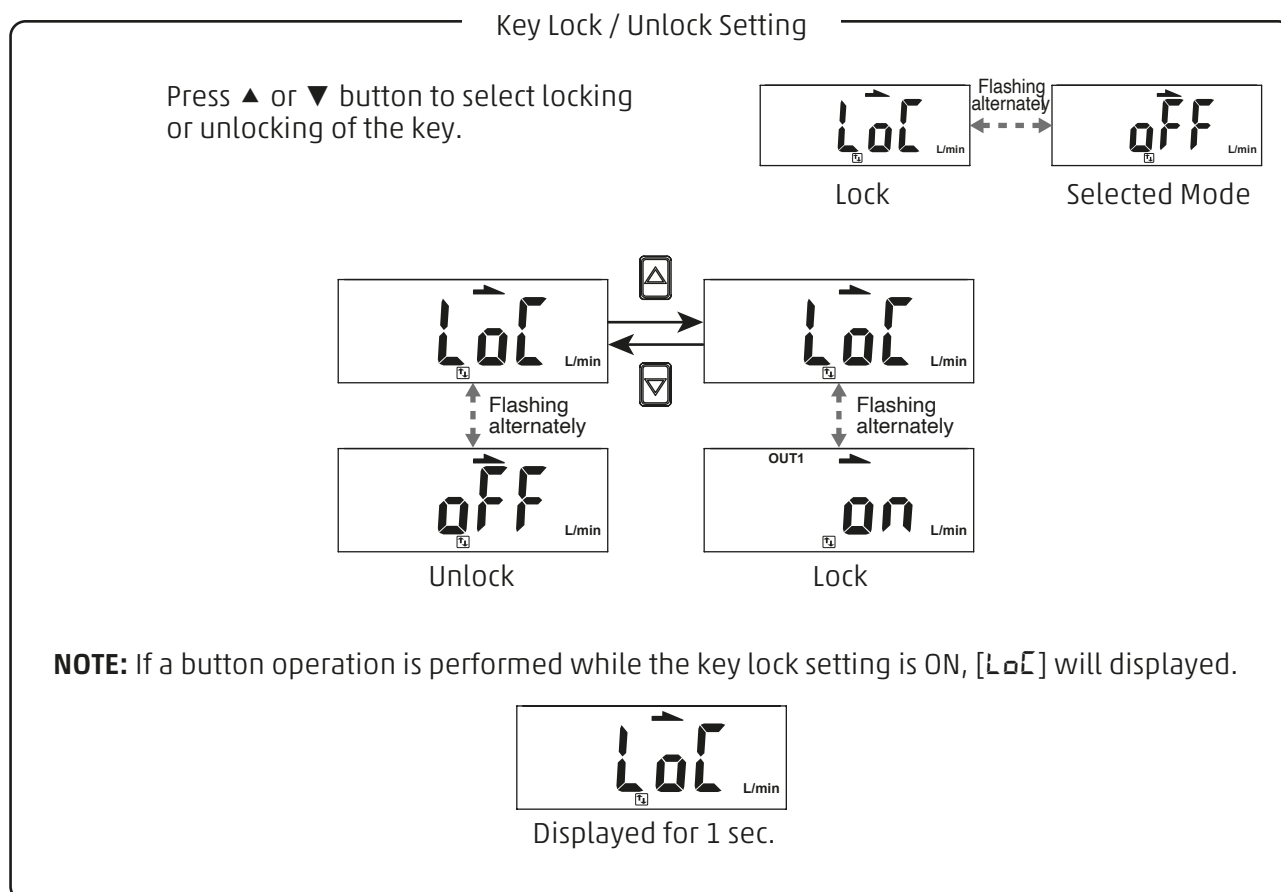

#### < Operation >

Press  button over 5 sec. at measurement mode to select key lock/unlock setting.

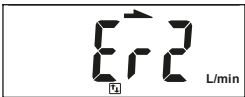
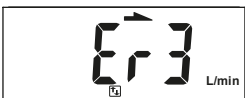

# Instruction

## 4.1 Error Code Instruction

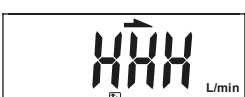
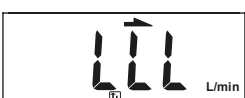
Error Type	Error Code	Error Condition	Troubleshooting
OUT1 Excess Load Current Error		Output 1 load current is more than 125 mA.	Turn power off and check the cause of overload current or lower the current load under 125 mA, then restart.
OUT2 Excess Load Current Error		Output 2 load current is more than 125 mA.	
Zero Adjustment Error		The instant flow is over $\pm 5\%$ F.S. of the zero point.	Perform the zero clear function again under no flow conditions.
System Error		Memory error.	Turn power off, and then restart. If error condition remains, please return to factory for inspection.
		Internal data error.	
		Internal data error.	
		System parameter error.	
Applied Error		The instant flow has exceeded the upper limit of the flow display range.	Reduce the flow to the display range.
		The instant flow has exceeded the lower limit of the flow display range.	Ensure the flow is in the correct direction.

# Specifications

Model	010		500		201	
Fluid	Dry air, N <sub>2</sub> , Non-corrosive / Non-flammable gas					
Measured flow rate range	0 ÷ 1 L/min		0 ÷ 50 L/min		0 ÷ 200 L/min	
Flow Direction	Unidirection					
<b>Display</b>	4 digital * 4 digital, 7 segment LCD display (Red / Green / Orange)					
Instant Flow Rate	Display Range		0 ÷ 1.050 L/min		0 ÷ 52.5 L/min	
	Minimum Setting Scale	LPM	1 mL/min		0.1 L/min	
		CFM *1	0.01 ft <sup>3</sup> /min		1 ft <sup>3</sup> /min	
Accumulated Flow	Display Range		99999999 mL		99999999 L	
	Minimum Setting Scale *1		1 mL		0.1 L	
			0.01 ft <sup>3</sup>		1 ft <sup>3</sup>	
<b>Accuracy</b>						
Guaranteed Range	2 ÷ 100 % F.S.					
Indicator Accuracy	± 3% F.S. ± 1 digit *2					
Analog Output Accuracy	± 5% F.S. *2					
Repeatability	± 1% F.S. ± 1 digit *3					
Linearity	± 3% F.S. *3					
Temp. Characteristic	± 2% F.S. (15÷35°C); ± 5% F.S. (0÷15°C, 35÷50°C) (compare with *3)					
Pressure Characteristic	± 5% F.S. ± 1 digit *4					
<b>Switch Output</b>						
	2NPN: open collector 2 outputs Max. Load Current: 125 mA Max. Supply Voltage: 28 V DC Voltage Drop: ≤ 1.5 V			2PNP: open collector 2 outputs Max. Load Current: 125 mA Max. Supply Voltage: 24 V DC Voltage Drop: ≤ 1.5 V		
Response Time	800 ms (50, 80, 120, 200, 400, 1500 ms selectable)					
Output Mode	Hysteresis Mode, Window Comparator Mode, Accumulated Output, Accumulated Pulse Output					
Hysteresis	Adjustable					
Output Short Circuit Protection	Yes					
Accumulated Pulse Output	10 mL/Pulse		0.5 L/Pulse		2 L/Pulse	
	0.04 ft <sup>3</sup> /Pulse		2 ft <sup>3</sup> /Pulse		7 ft <sup>3</sup> /Pulse	
<b>Analog Output</b>						
Voltage Output	1 ÷ 5 V - Output Impedance: 1 kΩ					
Current Output	4 ÷ 20mA - Load Impedance: ≤ 300 Ω					
Response Time	≤ 100 ms					
External Input	Non-voltage input , ≤ 0.4 V, ≥ 30 ms					
Communication interface	RS-485 *5					
Power Supply Voltage	12 ÷ 24V DC ± 10 % - Ripple (P-P) ≤ 10 %					
Current Consumption	≤ 50 mA					
<b>Environment</b>						
Working Pressure Range	-0.9 ÷ 8 bar					
Withstand Pressure	10 bar					
Enclosure	IP40					
Working Fluid Temp.	0 ÷ 50°C (No condensation or freezing)					
Ambient Temp. Range	Operation: 0 ÷ 50°C ; Storage: -10 ÷ 60°C (No condensation or freezing)					
Ambient Humidity Range	Operation / Storage: 35 ÷ 85 % R.H. (No condensation)					
Insulation Resistance	≥ 50 MΩ (500V DC , between case and lead wire)					
Withstand Voltage	1000 V AC 1-min (between case and lead wire)					
Vibration	Total amplitude 1.5 mm or 10 G, 10Hz - 55Hz - 10Hz scan for 1 minute, 2 hours each direction of X, Y and Z					
Shock	100 m/s <sup>2</sup> (10 G) , 3 times each in direction of X, Y and Z					
EMC	IEC 61000-6-2, IEC 61000-6-4					
Lead Wire	Ø4 Oil-resistance cable - 26 AWG (0.15 mm <sup>2</sup> ) - 6 cores					
<b>Port Size</b>	Ø6			Ø8		
Weight (with 2 Meter Lead Wire)	Approx. 109.3 g			Approx. 112.7 g		

## NOTE:

\*1: CFM ( ft<sup>3</sup>/min\*10<sup>-2</sup> ) and ft<sup>3</sup>\*10<sup>-2</sup>

\*2: CONDITION : Inlet Pressure : 3 bar, Outlet Pressure : 1 atmospheric pressure, 25 °

\*3: CONDITION : Outlet Pressure : 1 atmospheric pressure, 25 °

\*4: -0,9 ÷ 8 bar, Outlet Pressure : 1 atmospheric pressure, 25 °

\*5: This function only available for Output Specification -02 and -04

# Thermal Mass Flow Sensor Principles

## Symmetric Temperature Profile No Flow

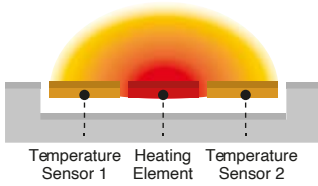

### (a):No Flow

In the absence of flow, the heat from the heater spreads evenly left and right, so the temperature distribution is like (a).

## Skewed Temperature Profile Small Flow

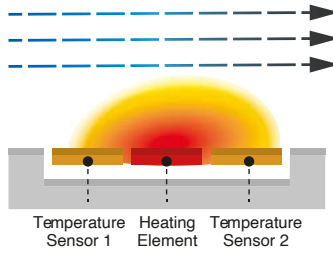

### (b):Small Flow

When flow begins, the inlet side is cooled by the flow, the outlet side is warmed by the heat of the inlet side of the heater, and the temperature distribution is like (b).

## Skewed Temperature Profile Large Flow

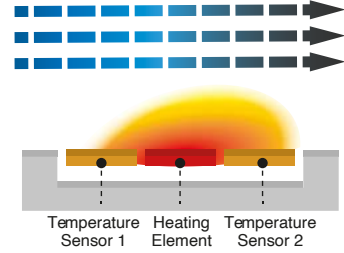

### (c):Large Flow

When the flow increases, it becomes a distribution like (C). Since the temperature distribution before and after the heater is proportional to the flow rate, the flow rate can be determined from the ratio.

# Ordering Information

<b>FS01</b>	-	<b>010</b>		<b>030</b>		<b>R6</b>
<b>FS01</b>	SERIES					
<b>010</b>	FLOW RATE RANGE 010 = 1 L/MIN 500 = 50 L/MIN 201 = 200 L/MIN					
<b>030</b>	OUTPUT SPECIFICATIONS 030 = 2 PNP output + Analog output 1÷5V 031 = 2 PNP output + Analog output 4÷20mA					
<b>R6</b>	PORT SIZE R6 = Ø6 mm, for Flow Rate Range 010, 500 R8 = Ø8 mm, for Flow Rate Range 201					
OPTIONAL PARTS FS-BT-26 = Mounting bracket FS-PA-G = Panel adapter FS-PA-H = Panel adapter + Front protective lid GM6X-2 = Connector 2mt GM6X-5 = Connector 5mt						

# Dimensions

## 1 . Product

- Ø6,Ø8

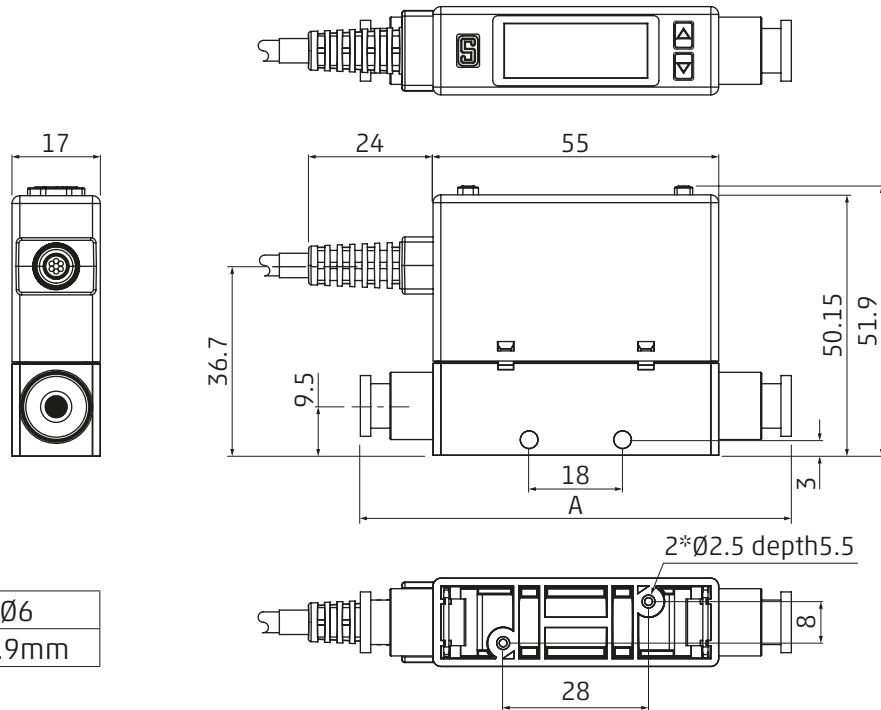

A	Ø8	Ø6
	92.1mm	82.9mm

## 2 . Mounting Bracket

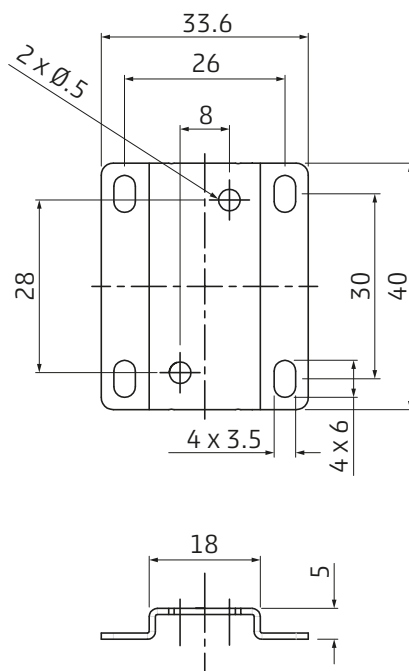

## Dimensions

### 3. Panel Mounting

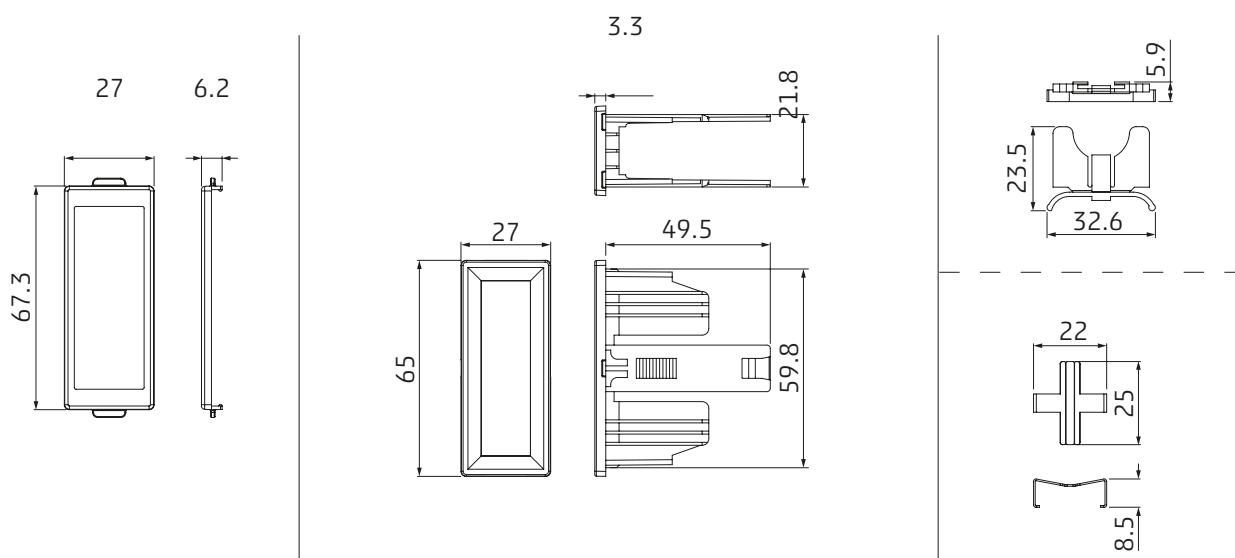

### 4. Panel Cut-Out

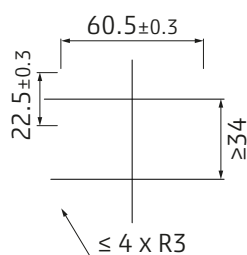

### 5. Cable

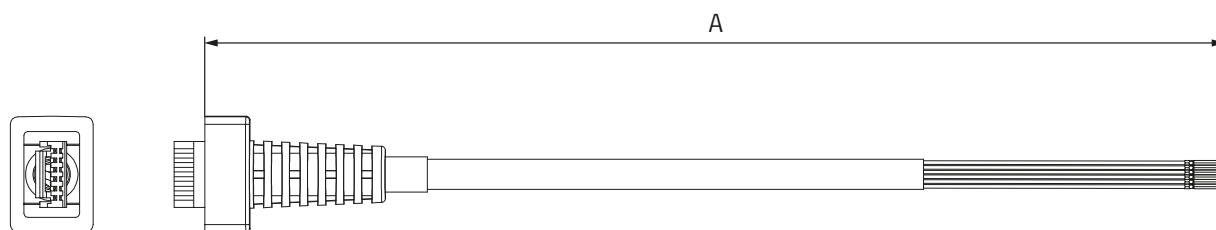

A	GM6X-2	GM6X-5
	2000mm	5000mm

# Construction

• Ø6,Ø8

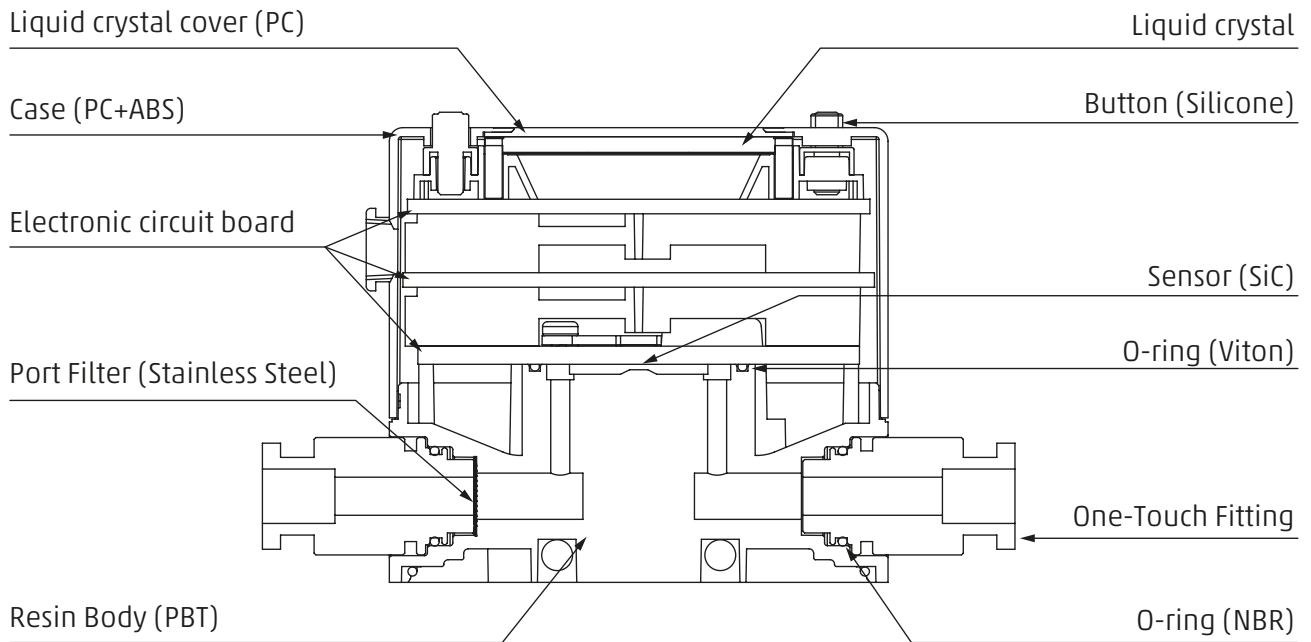



# Pressure Loss Characteristics

## • FS01-010- □ - □

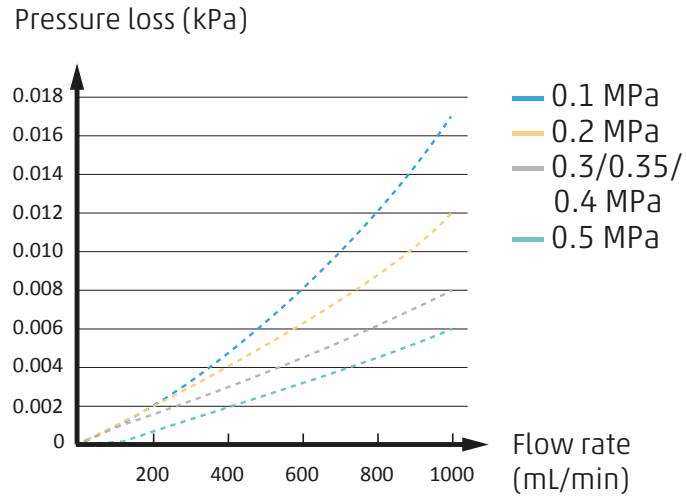

## • FS01-500- □ - □

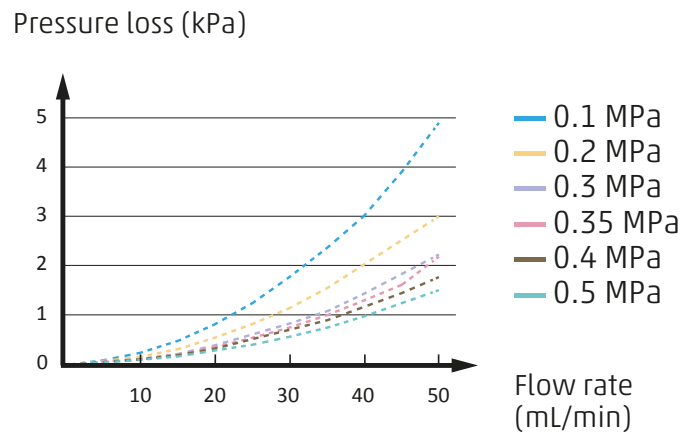

## • FS01-201- □ - □

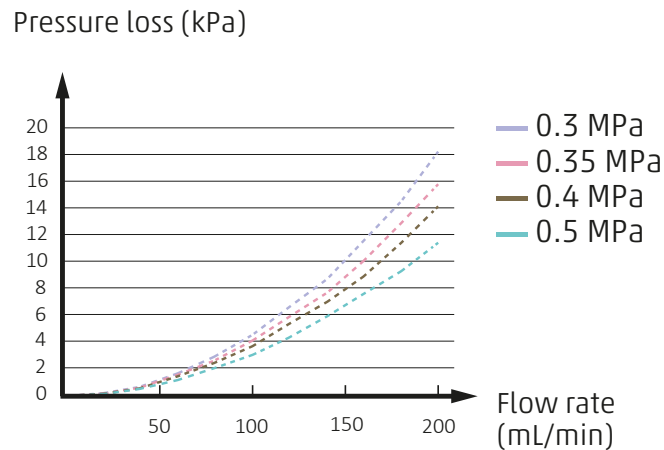

## Contacts

### **Camozzi Automation S.p.A.**

Società Unipersonale

REGISTERED OFFICE

Via R. Rubattino, 81  
20134 Milano

Italy

OPERATIONAL HEADQUARTERS

Via Eritrea, 20/I  
25126 Brescia

Italy

Tel. +39 030 37921

[www.camozzi.com](http://www.camozzi.com)

### **Customer Service**

Tel. +39 030 3792790

[service@camozzi.com](mailto:service@camozzi.com)

### **Product Certification**

Information concerning product  
certifications, EC standards,  
conformity declarations and instructions  
[productcertification@camozzi.com](mailto:productcertification@camozzi.com)



Automation

