

USE AND MAINTENANCE MANUAL



OPEN FRAME
PROPORTIONAL CONTROLLER
SERIE OF



Contents

Chapter 1 Introduction	1
1.1 General recommendations	1
1.2 Transport and storage of the product	2
1.3 Usage	2
1.4 Limitations of use	2
1.5 Maintenance	3
1.6 Environmental information	3
Chapter 2 General features	4
2.1 Product Description	4
2.2 Mechanical characteristics	5
2.3 Electrical characteristics	7
2.4 Commercial coding	8
Chapter 3 Control structure	9
3.1 General structure	9
3.2 Setpoint	9
3.3 Feedback	10
3.4 PID	11
3.5 Actuator	12
Chapter 4 Commissioning	13
4.1 Electrical connections	13
4.1.1 Pressure or flow control	13
4.1.2 Double acting position control	16
4.1.3 Single acting position control	22
4.2 Mechanical connections	24
4.3 Maximum operating pressure	26
4.4 Pressure control	27
4.5 Flow control	27
4.6 Position control	28
Chapter 5 Command signal	30
5.1 Analogic	30
5.2 CANopen	30
5.2.1 PDO	31
5.2.2 SDO	31
5.2.3 PEERs	31
5.3 IO-Link	32
5.4 RS485	33

5.5	RS232 e TTL	34
Chapter 6	Configuration and monitoring	35
6.1	UVIX Software	35
6.2	Device configuration	35
6.2.1	Internal Communication	35
6.2.2	Analog	36
6.2.3	Flow calculation	37
6.2.4	PID	37
6.2.5	Ramp	38
6.3	UVIX fast mode	38
6.4	Diagnostic	39

Introduction

1.1 General recommendations

The recommendations regarding safe use in this document should be observed at all times.

- Some hazards can only be associated with the product after it has been installed on the machine/equipment. It is the task of the final user to identify these hazards and reduce the associated risks accordingly.
- For information regarding component reliability, contact Camozzi.
- Before proceeding with use of the product, carefully read all information in this document.
- Keep this document in a safe place and close at hand for the whole of the product life cycle.
- Pass this document on to any subsequent holder or user.
- The instructions in this manual must be observed together with the instructions and additional information regarding the product in this manual, available from the following reference links:
 - Web site www.camozzi.com.
 - Camozzi general catalogue.
 - Technical assistance service.
- Assembly and start-up operations must be performed exclusively by qualified and authorised personnel on the basis of these instructions.
- It is the responsibility of the system/machine designer to ensure the correct selection of the most suitable pneumatic component according to the intended application.
- The use of appropriate personal protection is recommended to minimise the risk of injury.
- For all situations not contemplated in this manual and in situations in which there is the risk of potential damage to objects, or injury to persons or animals, contact Camozzi for advice.
- Never make unauthorised modifications to the product. In this case, any damage or injury to objects, persons or animals will be the responsibility of the user.

1.2 Transport and storage of the product

- All relevant product safety standards must be observed at all times.
- Never intervene on the machine/system before verifying that all working conditions are safe.
- Before installation and maintenance, ensure that the specific envisaged safety locks are active, and then disconnect the power supply (if necessary) and system pressure supply, discharging all residual compressed air from the circuit and deactivating residual energy stored in springs, condensers, recipients and gravity.
- After installation or maintenance, reconnect the system's pressure and power supply (where necessary) and check the proper operation and tightening of the product. In case of leaks or malfunctioning, the product must not be put into operation.
- Avoid covering the equipment with paint or other substances that may reduce heat dissipation.

1.2 Transport and storage of the product

- Adopt all measures possible to avoid accidental damage to the product during transport, and when available use the original packaging.
- Observe the specified storage temperature range of $-10 \div 50$ °C.

1.3 Usage

- Ensure that the voltage of the network and that all operating conditions remain within the admissible values.
- The product should only be put into operation if all of the Camozzi defined specifications and criteria are met. If they are not met, the product should only be put into operation after receiving approval from Camozzi.
- Observe the specifications on the identification data plate.

1.4 Limitations of use

- Never exceed the technical specifications stated in Chapter 2 "General characteristics and conditions of use" and in the Camozzi general catalogue.

1.5 Maintenance

- Do not install the product in environments where the air itself may cause hazards.
- With the exception of specific intended uses, do not use the product in environments where direct contact with corrosive gases, chemicals, salt water, water or steam may occur.

1.5 Maintenance

- Incorrectly performed maintenance operations can compromise the correct functioning of the product and may lead to injuries of surrounding persons.
- Check all conditions to prevent the sudden release of parts and disconnect the power supply to enable the discharge of residual pressure from the system before intervening.
- Check whether it is possible to have the product serviced at a technical assistance center.
- Never disassemble units when energised.
- Isolate the product electrically before starting with maintenance.
- Always remove all accessories before starting with maintenance.
- Always wear the correct safety equipment required by local authorities and according to legislative regulations in force.
- In the event of maintenance or replacement of worn parts, only use original Camozzi kits and ensure that operations are only performed by specialised and authorised personnel. Otherwise product approval will become invalid.

1.6 Environmental information

- At the end of the product's life cycle, separate the relative materials to enable recycling.
- Observe all current standards in the country of use governing waste disposal.
- The product and relative parts all comply with the ROHS and REACH standards.

General features

2.1 Product Description

The Open Frame device is a modular and configurable proportional regulator capable of making pressure, flow, or position adjustments to a pneumatic cylinder.

In its simplest configuration, the device consists of a single module called a head module, which allows you to create all 2-way versions under pressure or flow (device on the left in figure 2.1).

To make the 3-way versions (central device in figure 2.1), the above module is connected to a second type of module called expansion module; the device thus composed is also used to make the 2-way high-flow versions and the single acting positioner with non-analog control.

The single acting positioner is the only device that has two configurations based on the command signal, the version with analog control is made up of two head modules (device on the right in figure 2.1) unlike the non-analog versions which, as we have seen, are composed of a head module and an expansion module.



Figure 2.1: 2-way version on the left, 3-way version at centre and analog single acting positioner on the right

The last possible configuration is that of the double acting positioner (fig 2.2); in this case there are two pairs made up of a master module and expansion module connected together and suitably configured to simultaneously control the two chambers of the pneumatic cylinder.

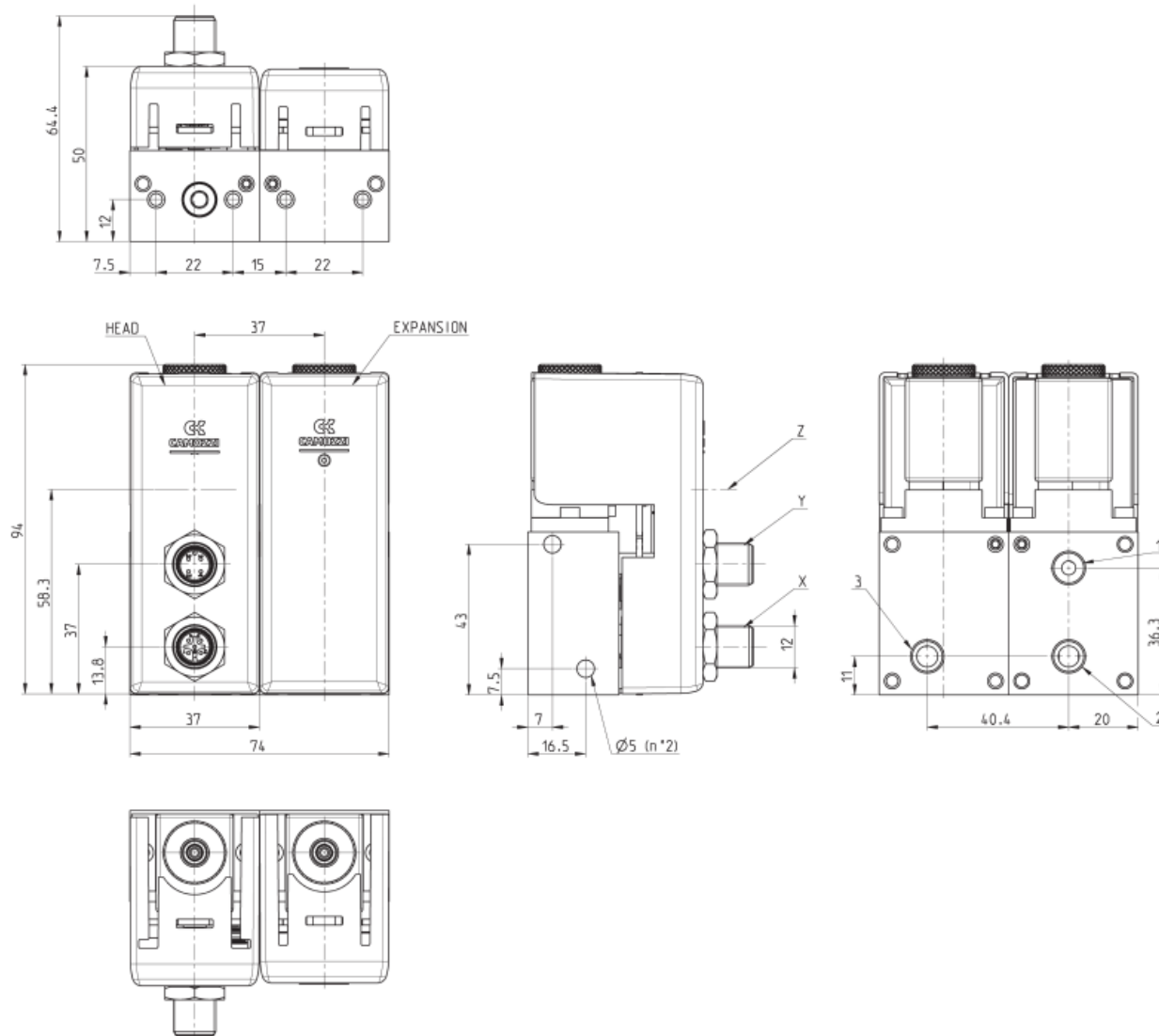

Figure 2.2: Version for the position control of a pneumatic cylinder

2.2 Mechanical characteristics

2.2 Mechanical characteristics

Below are some representative drawings for the electrical and pneumatic parts. In particular, we can see the air inlet (1), the use (2) and the outlet (3).



2.2 Mechanical characteristics

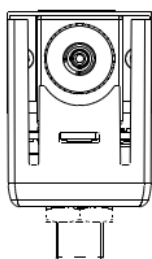
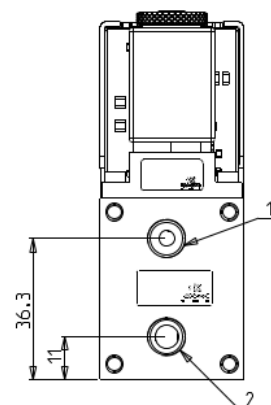
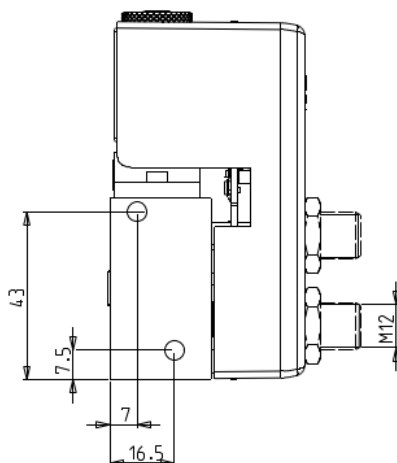
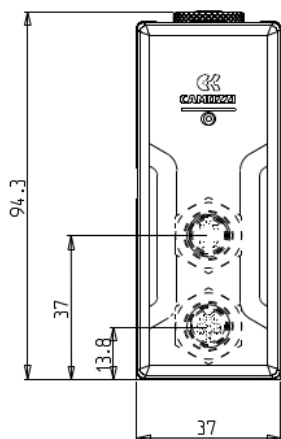
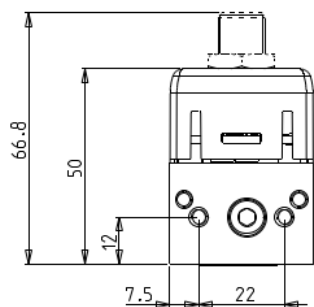

Mod.	X	Y	Z	A	B	C	M4
OF-2	M12 5 PIN (Male)	M12 5 PIN (Male)	Micro USB	G1/8	G1/8	G1/8	M4 thread for mounting

For the position regulator there is the air inlet (1), the use (2) and the outlet (3) as in figure below.

2.3 Electrical characteristics

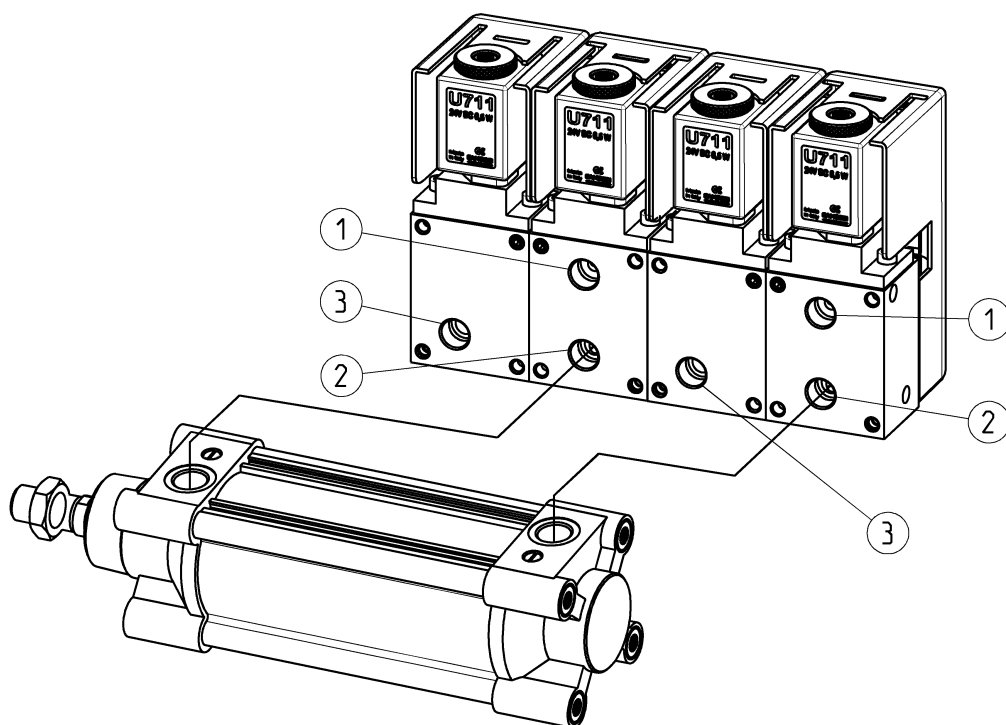

2.3 Electrical characteristics

Feature	Description	Notes
Supply voltage	24V \pm 10%	
	12V \pm 10%	
Current absorbed	0.3A	max. per master module
	CANopen	CiA301
	IO-Link	Port class B
	Analogico 0-10V	Resistenza d'ingresso 85k Ω
Command signal	Analogico 4-20mA	Resistenza d'ingresso 500 Ω
	RS232	
	RS485	
	TTL	
Analog output	0-10V	max. load current 20 mA
PID time	1ms	Elapsed time between two PID calculations

2.4 Commercial coding

2.4 Commercial coding

OF - 0 P 1 1 - L L W 2 - D - A - 04 - OX1

OF	SERIES: Open Frame
0	ELECTRICAL INTERFACE: 0 = 0 ÷ 10V analog / 24V supply 1 = CANopen / 24V supply 2 = IOLink -> CAN / 24V supply Portclass B compatible 8 = 4 ÷ 20mA analog / 24V supply 9 = no header / 24V 4 = 0 ÷ 10V analog / 12V supply 5 = CANopen / 12V supply 7 = 4 ÷ 20mA analog / 12V supply A = no header / 12V
P	CONTROL FUNCTION: A = Open Loop (flow 2-way) Master B = Open loop (flow 3-way) Master & Slave Q = Flow 2- way closed loop Master C = Flow 3 way closed loop Master & Slave H = high flow 2-way pressure control (parallel) Master & Slave J = high flow 2 way flow control with booster (parallel) Master & Slave N = pressure 2-way closed loop P = pressure 3-way closed loop Master & Slave W = position Controller single ended function Master & Slave Z = position Controller double ended function Master & Slave
1	SIZE: 1 = size 37 mm
1	PNEUMATIC PORT: 1 = G1/8
L	MASTER VALVE SIZE: F = Ø 1 mm H = Ø 1,2 mm L = Ø 1,6 mm N = Ø 2 mm Q = Ø 2,4 mm
L	SLAVE VALVE SIZE: F = Ø 1 mm H = Ø 1,2 mm L = Ø 1,6 mm N = Ø 2 mm Q = Ø 2,4 mm
W	SEALS MATERIAL: W = FKM
2	BODY MATERIAL: 2 = brass/aluminum
D	MAX. PRESSURE (RELATIVE SENSOR) ONLY FOR MASTERS: B = 0,2 bar D = 2 bar E = 7bar F = 10 bar G = +/- 1 bar
A	MAX. PRESSURE (DIFFERENTIAL SENSOR) ONLY FOR MASTER: 0 = no dp sensor B = 200 mbar C = 1 bar
04	NOZZLE SIZE FOR MASTER ONLY: 00 = no nozzle 12 = 1.2mm 14 = 1.4mm 16 = 1.6mm 18 = 1.8mm 20 = 2.0mm 23 = 2.3mm 28 = 2.8mm
OX1	CERTIFICATION: OX1

Figure 2.3: Open Frame commercial coding

Control structure

3.1 General structure

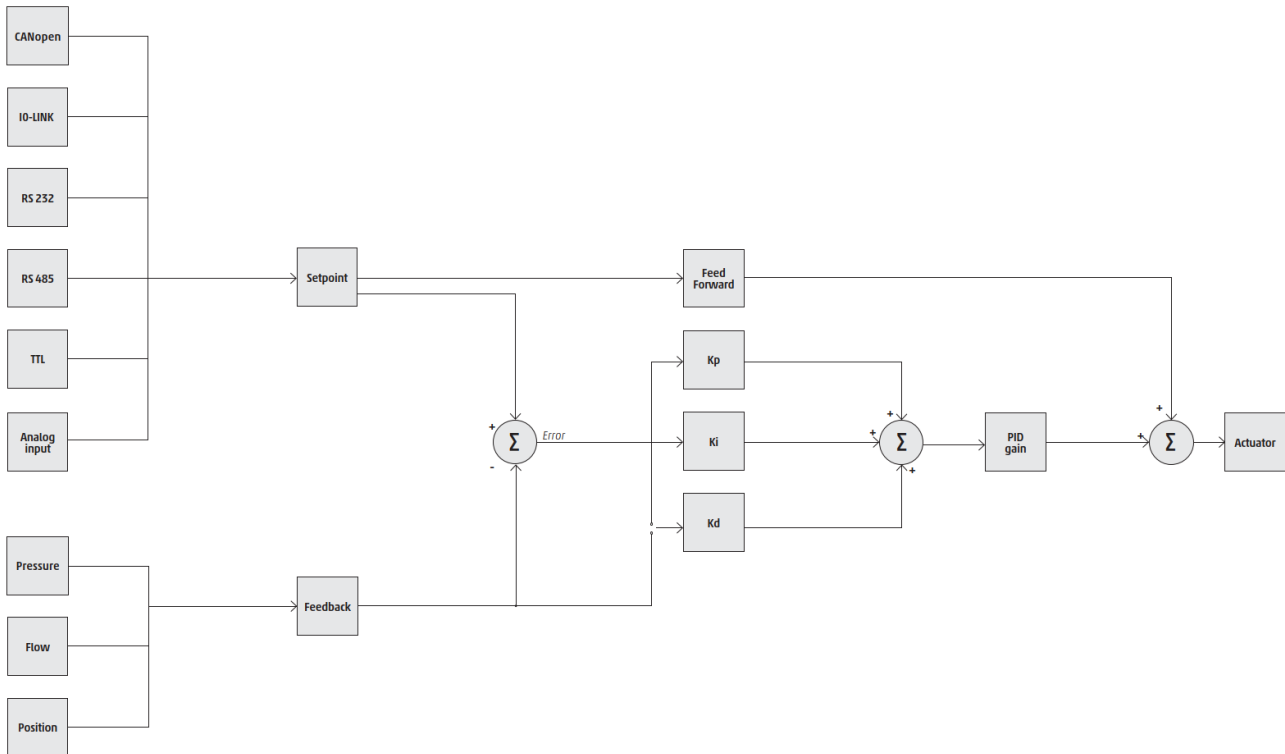

Figure 3.1: General structure

In figure 3.1 we can observe the general control structure of the Open Frame, from the reception of the setpoint and feedback essential to the PID to evaluate the action to perform to the actuation of the latter.

The Open Frame is a configurable device that allows this structure to be adapted to the application of the customer, thereby obtaining the most efficient solution. For more information on the configuration, see- chapter 6.

3.2 Setpoint

The setpoint, or command signal, is the value that the physical quantity must reach, that is regulated by the Open Frame (pressure, flow or position), expressed as a percentage in the regulating range. In figure 3.2 we can see the various electronic interfaces through which the device can receive the setpoint, depending on the one used; various configuration parameters are available which might be necessary to set during commissioning (for more details, see chapter 5).

3.3 Feedback

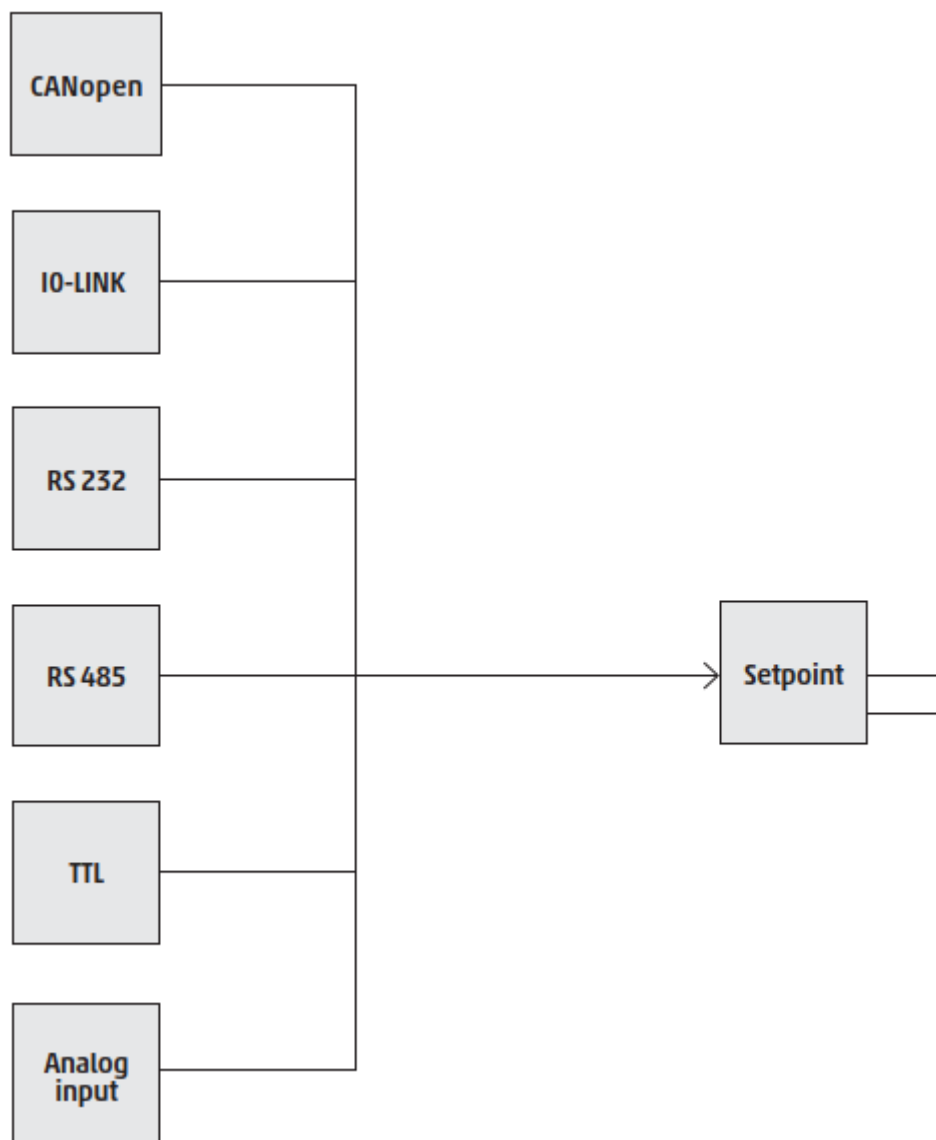

Figure 3.2: Control structure for setpoint acquisition

3.3 Feedback

The feedback is the actual value of the physical quantity that the Open Frame is regulating; reception depends on the type (see figure 3.3):

- Pressure: it is measured by the pressure sensor on the master module.
- Flow: it is calculated by an algorithm that takes into account the pressure measurements read through the two pressure sensors and the geometric dimensions of the device.
- Position: for correct operation, a position transducer must be present and connected to the pneumatic cylinder. Moreover it must be capable of providing the position of the latter through an analog signal (0-10V or 4-20mA); the position transducer must be connected to the analog input of the Open Frame and, depending on the type used, may need to be calibrated.

3.4 PID

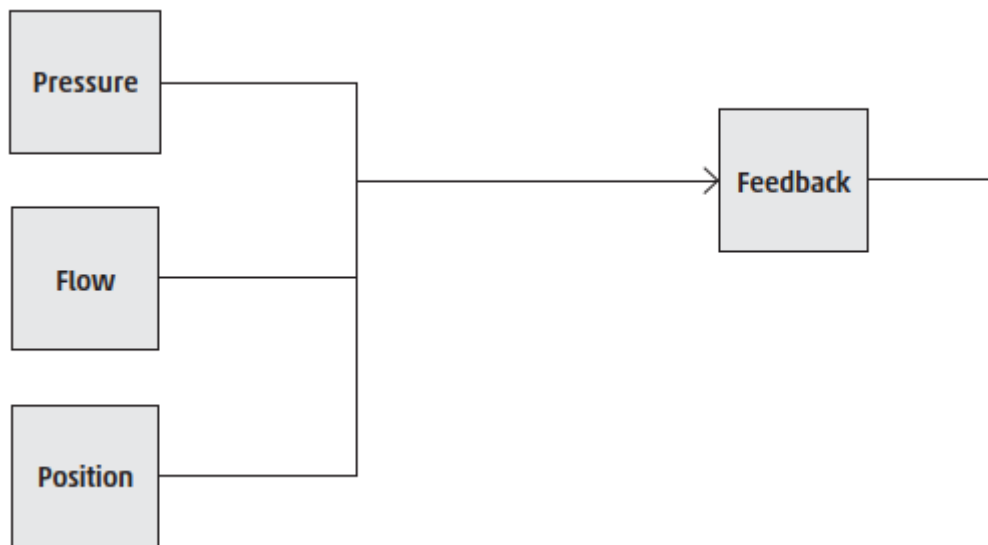

Figure 3.3: Control structure for receiving feedback

3.4 PID

The PID is the heart of the control which defines the behaviour of the device; see figure 3.4.

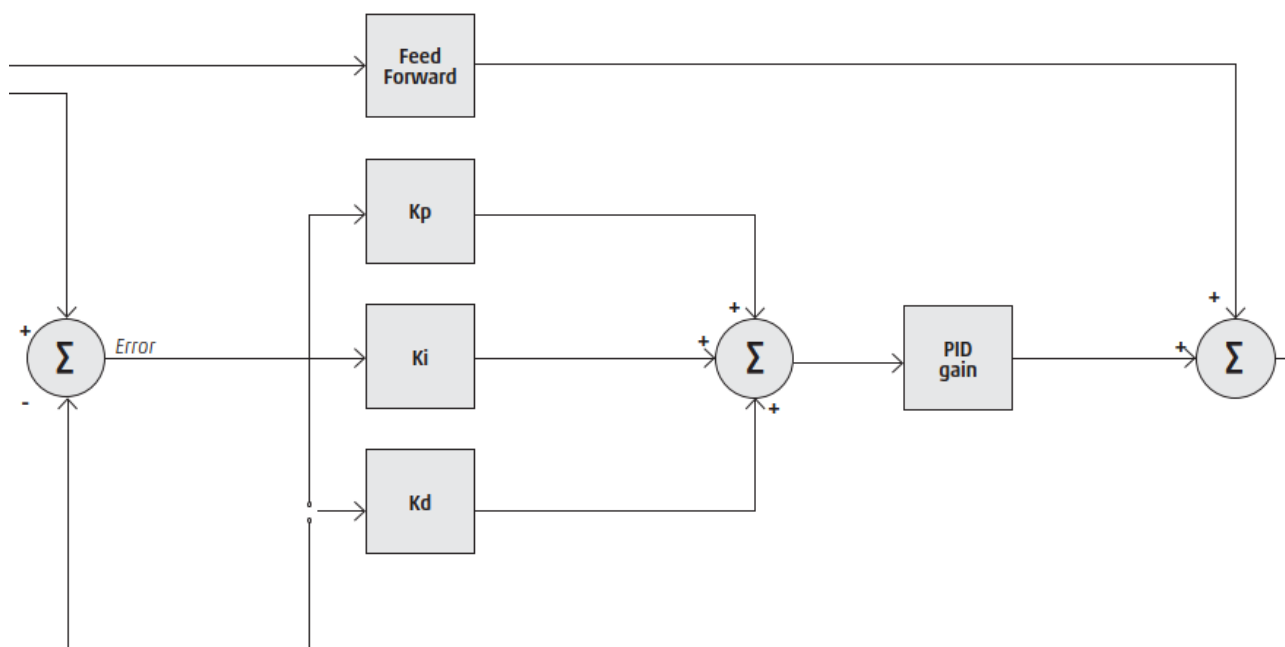

Figure 3.4: PID

The PID consists of the following elements:

3.5 Actuator

- Kp: proportional component of the PID.
- Ki: integral component of the PID.
- Kd: derivative component of the PID.
- PID gain: additional gain applied to all three components.
- Feed forward: is an add-on to the base PID, unaffected by feedback and is used to increase the responsiveness of the control.

3.5 Actuator

The actuator is the final part of the control structure that applies the action calculated from the PID; see figure 3.5.

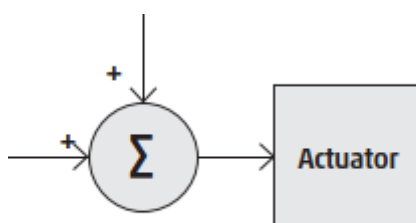

Figure 3.5: Actuator

The actuator has the task of generating the correct PWM, or the two PWMs in the case of the 3-way version, to supply to the valves.

Commissioning

4.1 Electrical connections

Il modulo master dell'Open Frame dispone di due connettori, quello inferiore è sempre un M12 5-pin chiave A mentre quello superiore in base alle versioni potrebbe essere identico al primo o un M12 5-pin chiave B.



In base alla versione utilizzata solo alcune connessioni sono necessarie, nei paragrafi seguenti sono mostrate tutte le configurazioni possibili.

The Open Frame master module has two connectors, the lower one is always an M12 5-pin, A-code while the upper one, depending on the versions, could be identical to the first or an M12 5-pin, B-code. Depending on the version used, only a few connections are required.



The following paragraphs show all possible configurations.

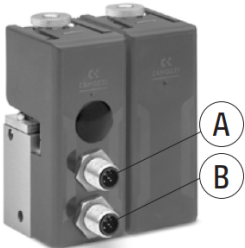

4.1.1 Pressure or flow control

Below are all the wiring diagrams in the case of pressure or flow control.

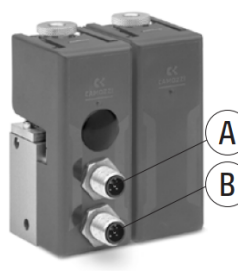
Analogue	Connector	Pin	Function	Description
	 <p>A - BUS</p>	1		Not used
		2		
		3		
		4		
		5		
	 <p>B - Power</p>	1	P24	Power Supply
		2	OUT	Analog output
		3	GND	Ground
		4	IN	Analog input
		5	EARTH	Earth connection

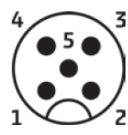

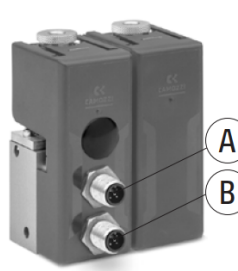
4.1 Electrical connections

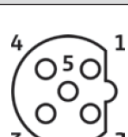
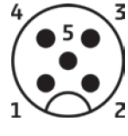

CANopen	Connector	Pin	Function	Description
	 A - BUS	1	SHIELD	Shield connection
		2		
		3	GND	Ground
		4	CAN_H	CAN-H bus line
		5	CAN_L	CAN-L bus line
	 B - Power	1	P24	Power Supply
		2	OUT	Analog output
		3	GND	Ground
		4		
		5	EARTH	Earth connection

IO-Link	Connector	Pin	Function	Description
	 A - BUS	1	L+	Power supply referred to L-
		2	P24	Additional power supply referred to N24
		3	L-	Power supply referred to L+
		4	C/Q	IO-Link communication
		5	N24	Additional power supply referred to P24
	 B - Power	1		
		2	OUT	Analog output
		3	GND	Ground
		4	IN	Analog input
		5	EARTH	Earth connection

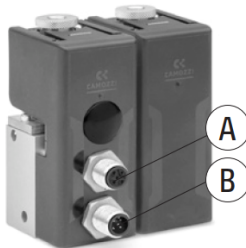
RS232	Connector	Pin	Function	Description
	 A - BUS	1	CTS	Clear to send
		2	TX	Transmit Data
		3	GND	Ground
		4	RX	Receive Data
		5	RTS	Request to send
	 B - Power	1	P24	Power Supply
		2	OUT	Analog output
		3	GND	Ground
		4		
		5	EARTH	Earth connection

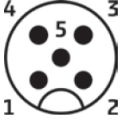
4.1 Electrical connections

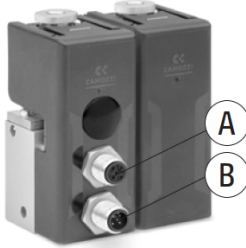
RS485	Connector	Pin	Function	Description
	 A - BUS	1		
		2	D-	Differential negative line
		3	GND	Ground
		4		
		5	D+	Differential positive line
	 B - Power	1	P24	Power Supply
		2	OUT	Analog output
		3	GND	Ground
		4		
		5	EARTH	Earth connection

TTL	Connector	Pin	Function	Description
	 A - BUS	1		
		2	TX	Transmit Data
		3	GND	Ground
		4	RX	Receive Data
		5		
	 B - Power	1	P24	Power Supply
		2	OUT	Analog output
		3	GND	Ground
		4		
		5	EARTH	Earth connection





4.1 Electrical connections

4.1.2 Double acting position control

Below are all the wiring diagrams in the case of double acting position control.

Analog







Connector	Pin	Function	Description
 A - Not Used	1		Not used
	2		
	3		
	4		
	5		
 B - Power	1	P24	Power supply
	2	OUT	Analog output
	3	GND	Ground
	4	IN	Analog input
	5	EARTH	Earth connection
 C - Not Used	1		Not used
	2		
	3		
	4		
	5		
 D - Position Feedback	1	P24	Power Supply
	2	OUT	Fixed analog output 10V
	3	GND	Ground
	4	IN	Position Feedback
	5	EARTH	Earth connection

4.1 Electrical connections

CANopen







Connector	Pin	Function	Description
 A - BUS	1	SHIELD	Shield connection
	2		
	3	GND	Ground
	4	CAN_H	CAN-H bus line
	5	CAN_L	CAN-L bus line
 B - Power	1	P24	Power Supply
	2		
	3	GND	Ground
	4		
	5	EARTH	Earth connection
 C - Not Used	1		Not used
	2		
	3		
	4		
	5		
 D - Position Feedback	1	P24	Power Supply
	2	OUT	Fixed analog output 10V
	3	GND	Ground
	4	IN	Position Feedback
	5	EARTH	Earth connection

4.1 Electrical connections

IO-Link







Connector	Pin	Function	Description
 A - BUS	1	L+	Power supply referred to L-
	2	P24E	Additional supply referred to N24
	3	L-	Power supply referred to L+
	4	C/Q	IO-Link communication
	5	N24	Additional power supply referred to P24
 B - Not used	1		
	2	OUT	Analog output
	3	GND	Ground
 C - Not Used	1		Not used
	2		
	3		
	4		
	5		
 D - Position Feedback	1		
	2	OUT	Fixed analog output 10V
	3	GND	Ground
	4	IN	Position Feedback
	5	EARTH	Earth connection

4.1 Electrical connections

RS232







Connector	Pin	Function	Description
 A - Serial	1	CTS	Clear to send
	2	TX	Transmit Data
	3	GND	Ground
	4	RX	Receive Data
	5	RTS	Request to send
 B - Power	1	P24	Power supply
	2	OUT	Analog output
	3	GND	Ground
	4		
	5	EARTH	Earth connection
 C - Not Used	1		Not used
	2		
	3		
	4		
	5		
 D - Position Feedback	1	P24	Power Supply
	2	OUT	Fixed analog output 10V
	3	GND	Ground
	4	IN	Position Feedback
	5	EARTH	Earth connection





4.1 Electrical connections

RS485



Connector	Pin	Function	Description
 <p>A - Serial</p>	1		
	2	D-	Differential negative line
	3	GND	Ground
	4		
	5	D+	Differential positive line
 <p>B - Power</p>	1	P24	Power supply
	2	OUT	Analog output
	3	GND	Ground
	4		
	5	EARTH	Earth connection
 <p>C - Not Used</p>	1		Not used
	2		
	3		
	4		
	5		
 <p>D - Position Feedback</p>	1	P24	Power Supply
	2	OUT	Fixed analog output 10V
	3	GND	Ground
	4	IN	Position Feedback
	5	EARTH	Earth connection







4.1 Electrical connections

TTL			
			
Connector	Pin	Function	Description
 A - Serial	1		
	2	TX	Transmit Data
	3	GND	Ground
	4	RX	Receive Data
	5		
 B - Power	1	P24	Power supply
	2	OUT	Analog output
	3	GND	Ground
	4		
	5	EARTH	Earth connection
 C - Not Used	1		Not used
	2		
	3		
	4		
	5		
 D - Position Feedback	1	P24	Power Supply
	2	OUT	Fixed analog output 10V
	3	GND	Ground
	4	IN	Position Feedback
	5	EARTH	Earth connection



4.1 Electrical connections

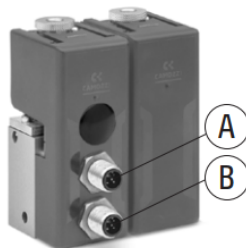

4.1.3 Single acting position control

Below are all the wiring diagrams in the case of single acting position control.

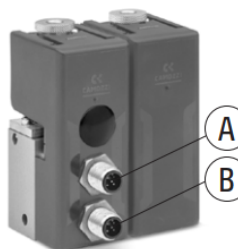
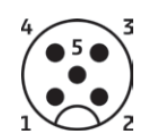
Analogue	Connector	Pin	Function	Description
	 A - Not Used	1		Not used
		2		
		3		
		4		
		5		
	 B - Power	1	P24	Power supply
		2	OUT	Analog output
		3	GND	Ground
		4	IN	Analog input
		5	EARTH	Earth connection
	 C - Not Used	1		Not used
		2		
		3		
		4		
		5		
	 D - Position Feedback	1	P24	Power Supply
2		OUT	Fixed analog output 10V	
3		GND	Ground	
4		IN	Position Feedback	
5		EARTH	Earth Connection	
CANopen	Connector	Pin	Function	Description
	 A - BUS	1	SHIELD	Shield connection
		2		
		3	GND	Ground
		4	CAN_H	CAN-H bus line
		5	CAN_L	CAN-L bus line
	 B - Power	1	P24	Power Supply
		2	OUT	Analog output
		3	GND	Ground
		4	IN	Position Feedback
		5	EARTH	Earth Connection

4.1 Electrical connections

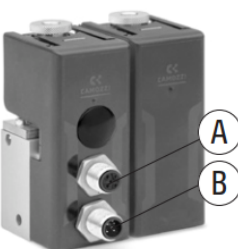
IO-Link	Connector	Pin	Function	Description
	 A - BUS	1	L+	Power supply referred to L-
		2	P24	Additional supply referred to N24
		3	L-	Power supply referred to L+
		4	C/Q	IO-Link communication
		5	N24	Additional power supply referred to P24
	 B - Power	1		
		2	OUT	Analog output
		3	GND	Ground
		4	IN	Position Feedback
		5	EARTH	Earth connection

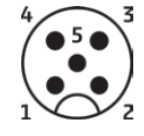
RS232	Connector	Pin	Function	Description
	 A - BUS	1	CTS	Clear to send
		2	TX	Transmit Data
		3	GND	Ground
		4	RX	Receive Data
		5	RTS	Request to send
	 B - Power	1	P24	Power Supply
		2	OUT	Analog Output
		3	GND	Ground
		4	IN	Position Feedback
		5	EARTH	Earth connection

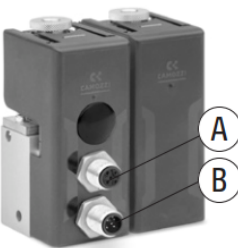
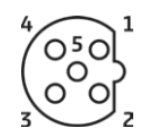
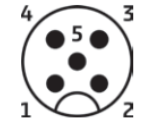
RS485	Connector	Pin	Function	Description
	 A - BUS	1		
		2	D-	Differential negative line
		3	GND	Ground
		4		
		5	D+	Differential positive line
	 B - Power	1	P24	Power Supply
		2	OUT	Analog output
		3	GND	Ground
		4	IN	Position Feedback
		5	PE	Earth connection

4.2 Mechanical connections

TTL	Connector	Pin	Function	Description
	 A - BUS	1		
		2	TX	Transmit Data
		3	GND	Ground
		4	RX	Receive Data
		5		
	 B - Power	1	P24	Power supply
		2	OUT	Analog output
		3	GND	Ground
		4	IN	Position Feedback
		5	EARTH	Earth connection

4.2 Mechanical connections

Connection of the regulator to the wall with optional bracket cod. OF-ST.
To connect two or more modules together in series, proceed as follows:

- Attach the L-bracket with screws to the underside of the Open Frame body.
- Attach the L-bracket with screws to wall or DIN brackets.

ATTENTION: Make sure that the bracket is completely resting on the wall.

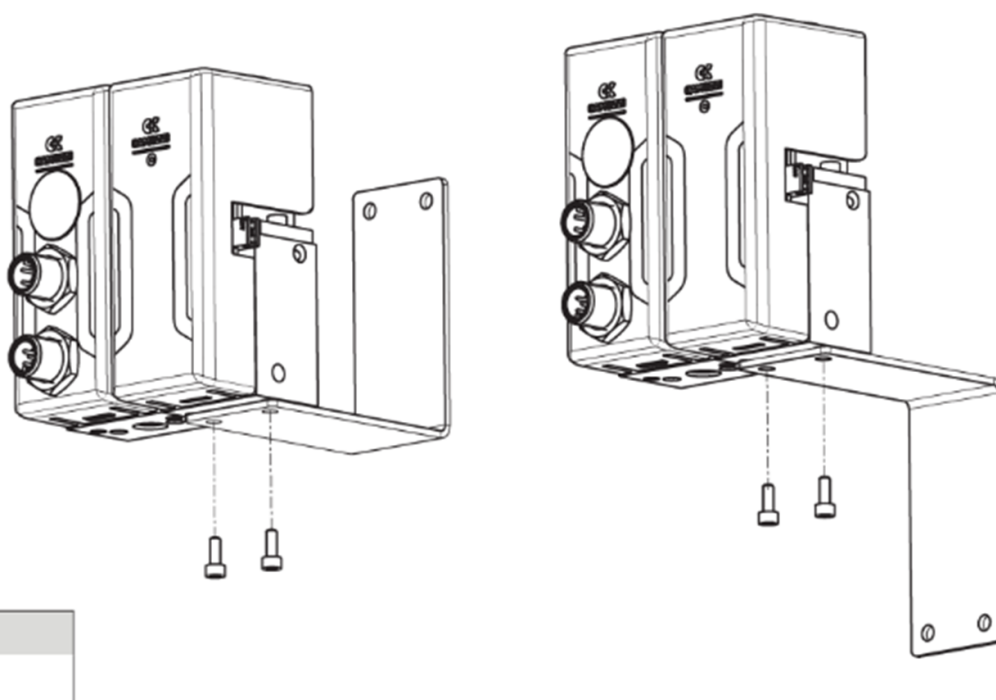

Mounting bracket for DIN rail Open Frame.

4.2 Mechanical connections

DIN EN 50022 (7.5 mm x 35 mm - thickness 1).

The supply includes a mounting bracket and M4x6 UNI 5931 screw.

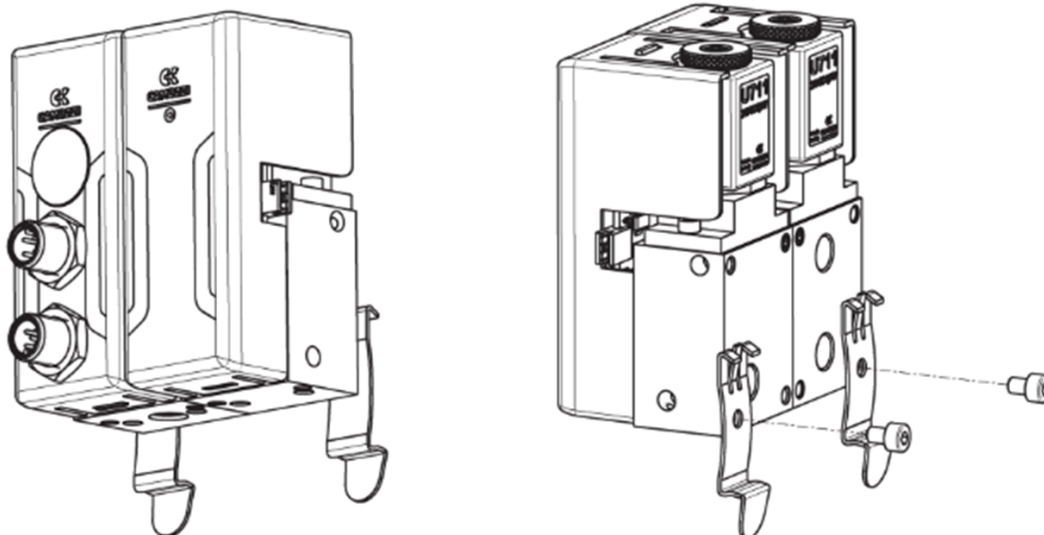

Mod.

PCF-K8P

Connection of manifold regulators with relative OF-M-PIN Kit.

To connect two or more modules together in series, proceed as follows:

1. Insert the pins (1) in the seats in the regulator body.
2. Insert the plastic connector paying attention to the direction.
3. Move the two modules laterally until they touch.
4. Screw in the four grub screws (2) until locked.

4.3 Maximum operating pressure

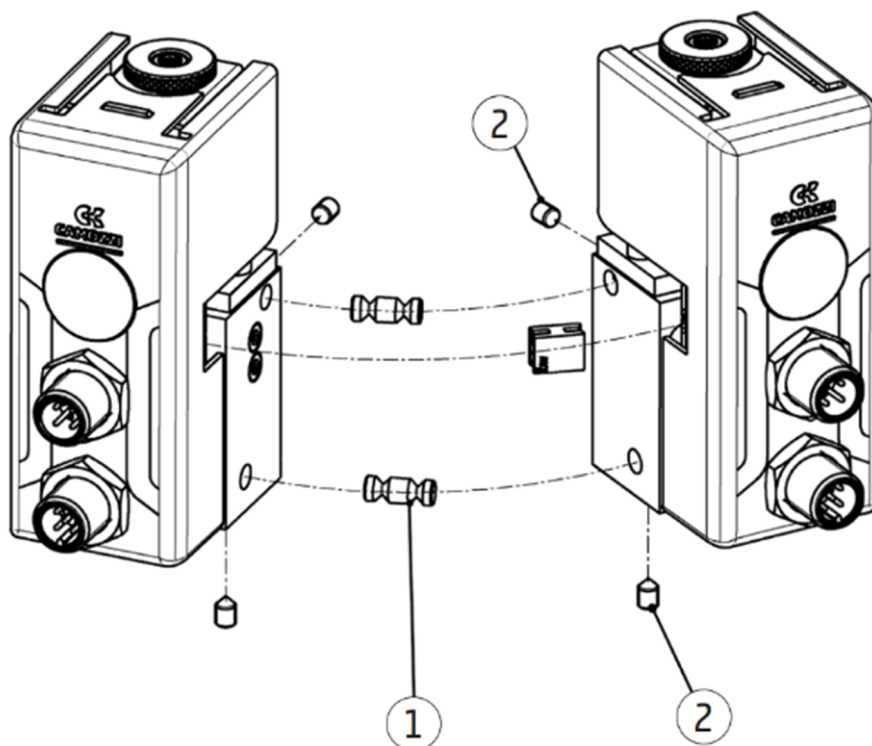

4.3 Maximum operating pressure

The maximum operating pressure is the lower between the maximum pressure of the proportional valves and the full scale of the relative pressure sensor. To find out which components are present, see commercial code (fig 2.3).

The following table shows the maximum pressures according to the mounted valve.

Commercial code	Nozzle diameter [mm]	Maximum valve pressure [bar]
F	1	10
H	1.2	8
L	1.6	6
N	2	5
Q	2.4	4

The following table however shows the full scale of the relative pressure sensors, if any.

4.4 Pressure control

Commercial coding	Sensor full scale [bar]
B	0.2
D	2
E	7
F	10
G	±1

Example: OF-0P11-LHW2-E-0-00-OX1.

In this example we have an Open Frame with 3-way pressure control, and the elements to be analysed are:

- Master valve 'L': maximum pressure 6 bar.
- Slave valve 'H': maximum pressure 8 bar.
- Relative sensor 'E': full scale 7 bar.

The operating pressure is the lowest of the three and in this example it is 6 bar.

4.4 Pressure control

During pressure control, the Open Frame interprets the setpoint received as a percentage within the range of regulation.

For proper operation, it is therefore fundamental to accurately derive the maximum operating pressure (chapter 4.3).

4.5 Flow control

The maximum flow that the device is able to control depends on the differential pressure sensor level and the calibrated nozzle used (see table below).

4.6 Position control

Differential pressure sensor	Calibrated nozzle diameter [mm]	Maximum flow [NL/min]
B	1,4	10
B	1,6	13
B	1,8	16
B	2,0	20
C	1,6	29
C	2,0	45
C	2,3	60
C	2,8	90

In addition to the maximum flow and maximum operating pressure, it is recommended to consider any back pressures introduced by the pneumatic circuit which might prevent the device from reaching the desired flow.

4.6 Position control

The Open Frame provides two ways of controlling the position of a pneumatic cylinder, single or double acting; for correct operation, a position transducer capable of providing the device with a 0-10V or 4-20mA signal is also required.

The choice and connection of the position transducer is the responsibility of the user. For this reason configurations of the analog input might be necessary (for more information, see chapter 6).

In single acting mode (fig 4.1), the device controls only one cylinder chamber and in the other chamber a pneumatic spring is applied.



Figure 4.1: Versions for single acting position control

In double acting mode (4.2), the device controls both cylinder chambers.



Figure 4.2: Version for the position control of a pneumatic cylinder

Command signal

5.1 Analogic

In the case of analog command, the setpoint is received with a 0-10V or 4-20mA signal, where 0V/4mA corresponds to a setpoint of 0% and 10V/20mA corresponds to a setpoint of 100%. The setpoint is read from the device via an ADC (analog-digital converter) which converts the analog signal in the range 0-4095; depending on the module used to provide the analog command and the machine where it is installed, it may be necessary to change the calibration values (see chapter 6).

5.2 CANopen

In the case of CANopen control, the device accepts a setpoint within the range -10000 and 10000, which corresponds to the range -100.00% and 100.00%. If the device is the last node of the network, you must enable the termination resistor of the communication line by using the switch on the head module under the plastic cover (see figure 5.1).

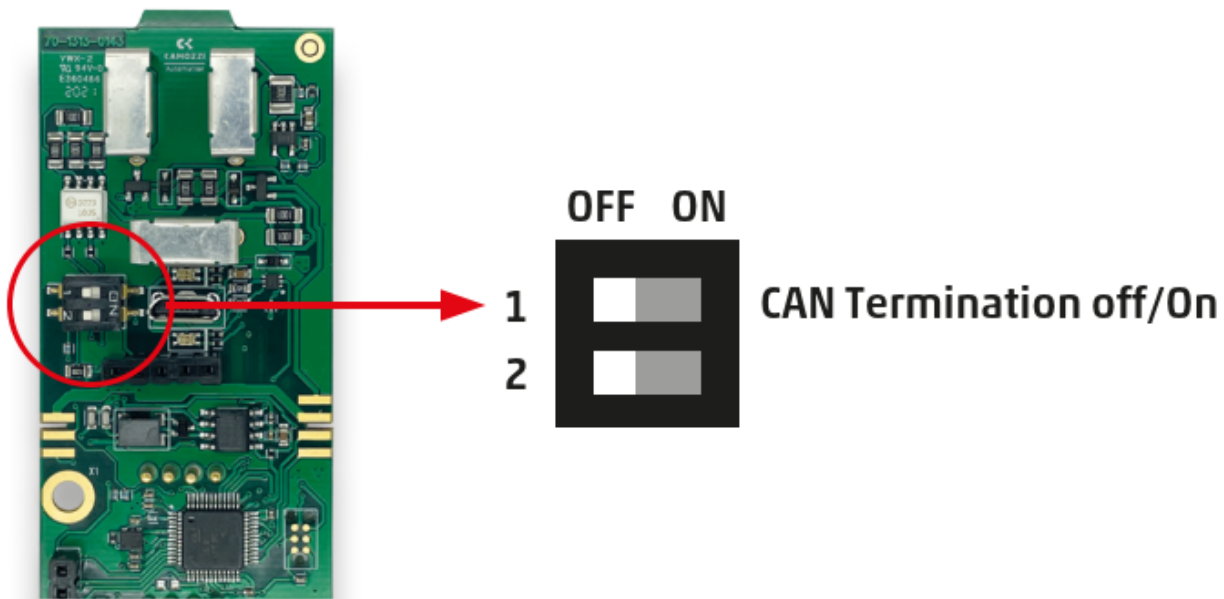

Figure 5.1: Switch to enable the CANopen termination resistor

For proper operation, please note that it is also necessary to correctly import the .eds file available on the Camozzi website and set the Node-ID and Baud Rate of the CANopen node consistently.

5.2 CANopen

5.2.1 PDO

Once the .eds file has been imported, the objects will be mapped automatically within the PDOs in the table below.

PDO	Nome	Dimensione[byte]	Descrizione
RPDO1	Setpoint	2	Command signal
	Free variable 1	2	Free variable for special applications
	Free variable 2	2	Free variable for special applications
	Free variable 3	2	Free variable for special applications
RPDO4	Reserved		Reserved for internal use
TPDO1	Feedback	2	Current value of the quantity adjusted
	Actuation value	2	Output value from the PID
	Errors	2	Device diagnostics
	Setpoint received	2	Setpoint received via RPDO1

5.2.2 SDO

The table below shows the device-specific parameters accessible via SDO.

Index	SubIndex	Descrizione
2FF2h	01h	Analog output
	02h	Relative pressure sensor reading
	03h	Differential pressure sensor reading
	04h	Calculated flow
2FF3h	01h	Master valve actuation value
	02h	Slave valve actuation value
2FF4h	01h	Proportional constant Kp
	02h	Integral constant Ki
	03h	Derivative constant Kd
	04h	Calculated value of the PID
	05h	PID value after gain
	06h	Feedback
	07h	Output value from Feed forward
	08h	Control deviation
2FF6h	01h	First ramp output value
	02h	Second ramp output value

5.2.3 PEERs

A concept related to CANopen communication that deserves further study is that of PEERs. If necessary, the OpenFrame can use the internal CANopen line to allow several head modules, from

5.3 IO-Link

two to a maximum of four, to communicate with each other.

One example is the case of the double acting positioner where, for proper operation the head modules must exchange setpoint and feedback."

For the correct operation of this internal communication, similar to a CANopen network, we have the following requirements:

- Network termination: the nodes at the ends of the network must have the terminating resistor enabled (see figure 5.1), in the example of the double acting positioner, the network consists of only two nodes. Therefore it must be enabled on both.
- Baud rate: the baud rate must be the same on all modules.
- CANopen state machine: as there is no CANopen master, you must set on each module that your state machine goes into the operational state automatically (for more details, see 6).
- Node ID: Each node on the network must have its own univocal Node ID.

After all the network nodes are configured properly, it is necessary to inform each of said nodes of the other nodes with which it must communicate; the PEERs are used for this purpose where the first one must be the Node-ID itself whereas from the second one (up to a maximum of four) must be informed of the other Node-IDs in the internal network and with which it must communicate.

Going back to the positioner example and assuming that the first node has Node-ID 1 and the second Node-ID 2, the PEERs of the first module will be PEER 1 = 1 and PEER 2 = 2 while the PEERs of the second module will be PEER 1 = 2 and PEER 2 = 1.

The internal network is not separated from any external network, assuming you have a positioner with CANopen electrical interface and which occupies Node-ID 1 and 2. It will also occupy both nodes in the CANopen network in which it will be inserted.

5.3 IO-Link

The Open Frame in IO-Link cyclically exchanges eight input bytes and eight output bytes (see table below). Available on the Camozzi website is also the IODD file which may be needed for commissioning.

5.4 RS485

Process Data	Name	Size[byte]	Description
PDIN	Setpoint	2	Setpoint
	Free variable 1	2	Free variable for special applications
	Free variable 2	2	Free variable for special applications
	Free variable 3	2	Free variable for special applications
PDOUT	Feedback	2	Current value of the quantity adjusted
	Analog input	2	Analog input value
	Relative sensor	2	Relative sensor reading of pressure
	Free variable 9	2	Free variable for special applications

5.4 RS485

In the event of RS485 communication, the baud rate is set by default at 38400 Bd and the message to be sent is composed as follows:

Data	Size[byte]
Address	1
Command	1
Data	2
Checksum	1

The address is not used in the case of point-to-point implementation. The command is composed as follows:

- Bit 7: 0 to indicate a request.
- Bits 6 e 5: 00 to indicate it is a setpoint.
- Bits 4: 0 to indicate that it is a process datum.
- Bits 3 to 0: number of bytes following the command including the checksum.

If you want to send a new setpoint, this value will be 3.

The Datum is a value between 0 and 10000 which corresponds to the range 0% to 100.00%; it must be transformed into a hexadecimal and the low part (LSB) must be sent first and then the high part (MSB). For example, if you want to send a target of 50%, the value will be 5000, converted into hexadecimal 1388h and when inverting the parts it will be 8813h.

The checksum is calculated with the formula:

$$(Command + LSB + MSB) \text{ mod } 256$$

5.5 RS232 e TTL

Resuming the previous example with a target of 50% we obtain:

$$\begin{aligned}
 \text{Comando} + \text{LSB} + \text{MSB} &= 158 = 0x9E \\
 \frac{0x9E}{0x100(256)} &= 0 \\
 0x9E - 0 &= 0x9E
 \end{aligned}$$

So the checksum is 0x9E.

The complete message will be: 0x3 0x88 0x13 0x9E.

The reply to the message is composed as follows:

Dato	Dimensione[byte]	Descrizione
0x89	1	Fixed value
Feedback	2	Feedback value
Analog input	2	Value of analog input
Relative sensor	2	Pressure read by the relative pressure sensor
Free variable 9	2	Free variable for special applications
Checksum	1	Checksum of response message

5.5 RS232 e TTL

The configurations for RS232 and TTL communications are:

Baud Rate	38400 Bd
Number of bits	8
Parity	none
Stop bit	1

The commands available are:

- SSP xxxxx: sets the setpoint to xxxxx (value between 0 and 10000 where 0 corresponds to 0% and 10000 to 100.00%), if received correctly, the device replies with the message →A!
- SAI 1000: Activates automatic sending of feedback every second, the response is 'ADR xxxxx yyyyy zzzz' where xxxxx equals xxx.xx% expressed as a percentage of the full scale.
- SAI 0: Disables the automatic sending of feedback.

Configuration and monitoring

6.1 UVIX Software

The proprietary Camozzi environment called UVIX allows the user to monitor and configure all new generation Camozzi devices (Camozzi Smart Device) that support connection to it.

The Open Frame belongs to this category of devices and is able to connect to the UVIX via USB cable.

This system has been implemented with a web-based architecture so that you can access the information through a simple browser.

For further details on the UVIX interface, refer to the specific manual (<http://catalogue.camozzi.com/Downloads.aspx?cat=205>).

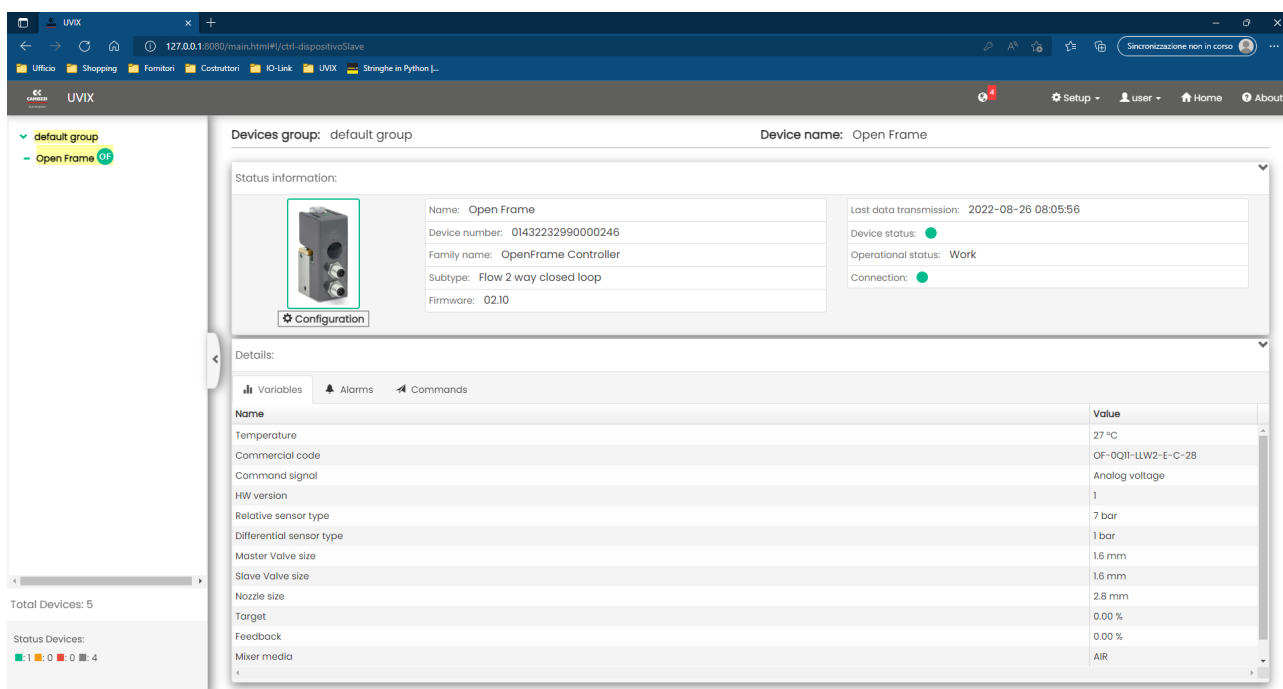

Figure 6.1: Home page of the UVIX interface

6.2 Device configuration

By clicking on the appropriate button, you can access the device configuration page (see figure 6.2), divided into the various menus where all the parameters can be modified.

6.2.1 Internal Communication

This menu contains the parameters for configuring internal communication.

6.2 Device configuration

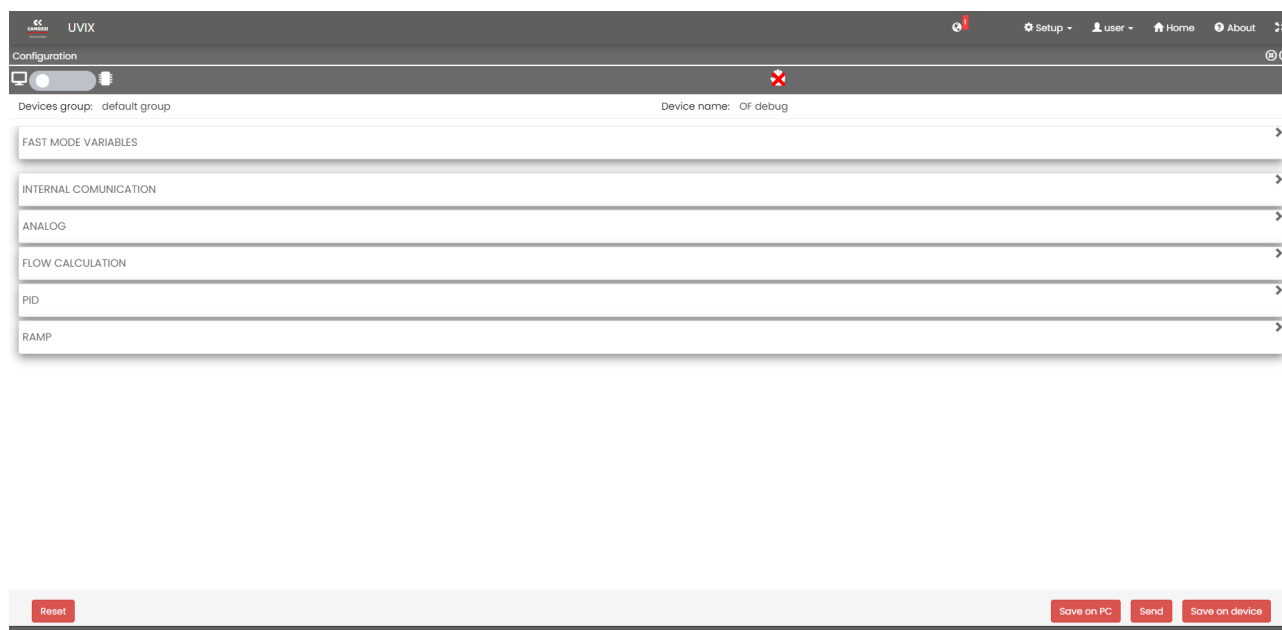

Figure 6.2: UVIX configuration page

Parameter	Range	Description
Node ID	0-127	Set the Node ID of the device
Set number of peers	0-4	Set the number of PEERs. Based on the number you entered, you can modify the parameters
Set Peer ID 1	0-127	Set the value of the first PEER
Set Peer ID 2	0-127	Set the value of the second PEER
Set Peer ID 3	0-127	Set the value of the third PEER
Set Peer ID 4	0-127	Set the value of the fourth PEER
State machine on bootup	Quiet bootup	Device does not send bootup message at startup
	OP state	Device sends bootup message at startup and automatically enters OP state
	Activate boot up message on selected node ID	Device sends bootup message and remains automatically enters OP state
Heartbeat	0-9999 ms	Set the heartbeat time

6.2.2 Analog

Dedicated menu for setting the analog input and output.

6.2 Device configuration

Parameter	Range	Description
Input mode	0-10V	Set the analog input live
	4-20mA	Set the analog input in current
Input lower calibration	0-4095	Calibration of the input at 10%
Input upper calibration	0-4095	Calibration of the input at 90%
Output lower calibration	0-4095	Output calibration at 10%
Output upper calibration	0-4095	Output calibration at 90%

6.2.3 Flow calculation

Dedicated menu for general device settings.

Parameter	Range	Description
Mixer media	Air	Set air as gas used
	O2	Set oxygen as gas used
	N2O	Set nitrous oxide as gas used
	N2	Set nitrogen as gas used
	CO2	Set carbon dioxide as gas used
	Argon	Set Argon as gas used
Flow media temperature	±100	Set temperature of the gas used

6.2.4 PID

Dedicated menu for setting the control loop.

Parameter	Range	Description
Kp	0-99999	The proportional constant value
Ki	0-99999	The integral constant value
Kd	0-99999	The derivative constant value
Differentiator mode	Off	Disable the derivative component value of the PID
	Error	Set the error as the source for the derivative component
	Feedback	Set the feedback as the source for the derivative component
Differentiator age	1-10	Set the number of samples that the derivative component must take into account
Feed forward value	0-10000	Set the feed forward value
Overall gain	0-10000	Set the additional gain value of the PID (PID gain)

6.3 UVIX fast mode

6.2.5 Ramp

Dedicated menu for setting the ramp, additional internal function useful in some applications.

Parametro	Range	Descrizione
Source	Off Analog input	Disables generation of the ramp Set analog input as the ramp
Rise time	0-10000	Set the time in ms that the ramp takes to reach 100% of the source from 0%
Fall time	0-10000	Set the time in ms that the ramp takes to reach 0% of the source from 100%
Start preset value	±10000	Set the initial value of the ramp

6.3 UVIX fast mode

Through the fast mode it is possible to configure the device in real time because the frequency of transmission of the variables is higher than the normal ones.

Accessible via the configuration command, it appears similar to the other menus. The fast variables are listed on a table where each of them indicates the current value, the minimum value and the maximum value since when the display started.

To the right of the variables are the manual commands in case you want to provide the setpoint directly from the UVIX.

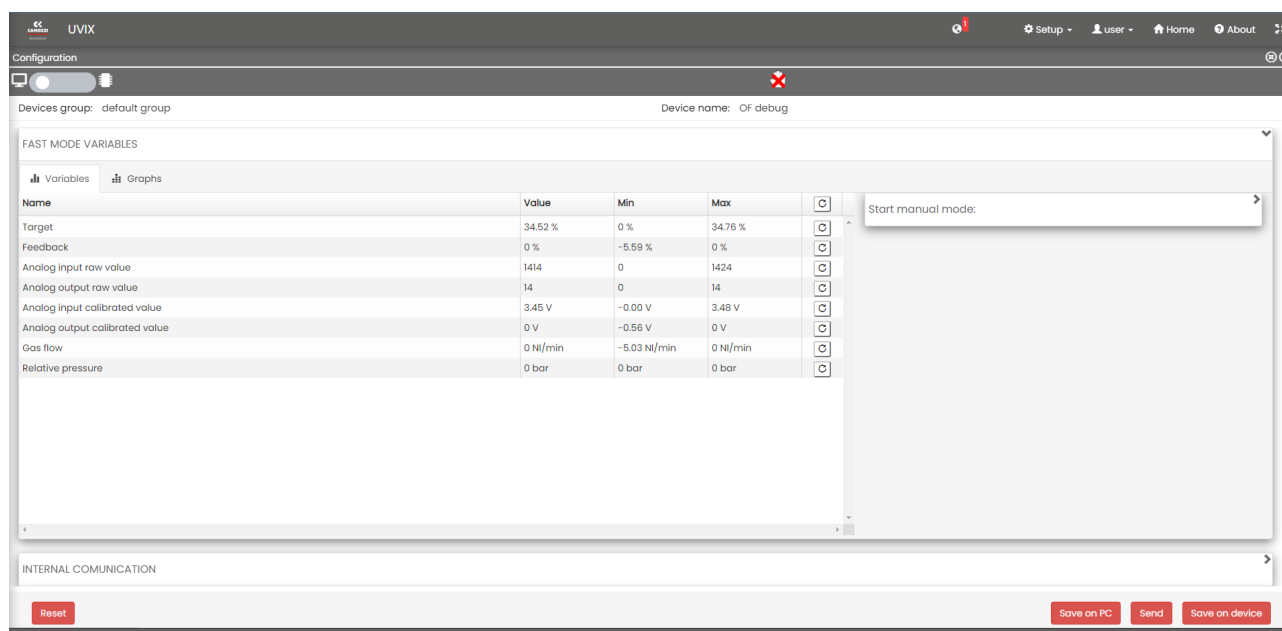

The screenshot shows the UVIX Configuration web interface. At the top, there are navigation links for Setup, user, Home, and About. The main content area is titled 'FAST MODE VARIABLES' and contains a table with the following data:

Name	Value	Min	Max	
Target	34.52 %	0 %	34.76 %	[icon]
Feedback	0 %	-5.59 %	0 %	[icon]
Analog input raw value	1414	0	1424	[icon]
Analog output raw value	14	0	14	[icon]
Analog input calibrated value	3.45 V	-0.00 V	3.48 V	[icon]
Analog output calibrated value	0 V	-0.56 V	0 V	[icon]
Gas flow	0 NI/min	-5.03 NI/min	0 NI/min	[icon]
Relative pressure	0 bar	0 bar	0 bar	[icon]

Below the table, there is a 'Start manual mode:' button. At the bottom of the interface, there are three buttons: 'Reset', 'Save on PC', and 'Send', followed by 'Save on device'.

Figure 6.3: Fast Mode

6.4 Diagnostic

The Open Frame is capable of autonomously transmitting error messages if it reveals any anomalous events; these events are divided into two types:

- Error: Critical errors that do not allow the device to work properly.
- Warning: non-critical alarms that could hinder correct operation.

The following table lists all possible error messages.

Event	Type	Description
Overheating	Error	Temperature out of the expected limits (0-60 °C)
Setpoint not reached	Warning	Setpoint not reached
Wrong input analog signal	Warning	If the command signal is analog in current, that means its value is lower than 4mA
Wrong setpoint	Warning	Indicates that the received setpoint is out of range 0-100%
Relative sensor missing	Error	The relative pressure sensor assembled does not operate properly
Differential sensor missing	Error	The differential pressure sensor assembled does not operate properly

Contatti

Camozzi Automation S.p.A.

Via Eritrea, 20/I
25126 Brescia - Italia
Tel. +39 030 37921
www.camozzi.com

Assistenza clienti

Tel. +39 030 3792790
service@camozzi.com

Certificazione di Prodotto

Informazioni relative a certificazioni
di prodotto, marcatura CE,
dichiarazioni di conformità e istruzioni
productcertification@camozzi.com



Automation

