

Operation and maintenance instructions Camozzi internal bus system



Made in Italy

The products are designed and manufactured in conformity with the following directives:

- 2004/108/CE

They also comply partially or totally with regard to the applicable parts of the following standards:

- CEI EN 61131-2

The website www.camozzi.it contains a section to download the relative CE Declarations of Conformity

1. Product identification

	Tabella di conversione della data di produzione.	86-1400-0001 Rev. D																																																																																																																																																																																																							
		Foglio 01 / 02																																																																																																																																																																																																							
<table border="1" style="width: 100%; border-collapse: collapse;"> <tr> <td align="center" colspan="4"> Posizione 1 e 2: n° della settimana. </td> <td align="center" colspan="4"> Posizione 3: Una lettera per l'anno in corso. </td> </tr> <tr> <td>01</td><td>14</td><td>27</td><td>40</td> <td>A</td><td></td><td>1996</td><td>2021</td><td>2046</td> </tr> <tr> <td>02</td><td>15</td><td>28</td><td>41</td> <td>B</td><td></td><td>1997</td><td>2022</td><td>2047</td> </tr> <tr> <td>03</td><td>16</td><td>29</td><td>42</td> <td>C</td><td></td><td>1998</td><td>2023</td><td>2048</td> </tr> <tr> <td>04</td><td>17</td><td>30</td><td>43</td> <td>D</td><td></td><td>1999</td><td>2024</td><td>2049</td> </tr> <tr> <td>05</td><td>18</td><td>31</td><td>44</td> <td>E</td><td></td><td>2000</td><td>2025</td><td>2050</td> </tr> <tr> <td>06</td><td>19</td><td>32</td><td>45</td> <td>F</td><td></td><td>2001</td><td>2026</td><td>2051</td> </tr> <tr> <td>07</td><td>20</td><td>33</td><td>46</td> <td>G</td><td></td><td>2002</td><td>2027</td><td>2052</td> </tr> <tr> <td>08</td><td>21</td><td>34</td><td>47</td> <td>H</td><td></td><td>2003</td><td>2028</td><td>2053</td> </tr> <tr> <td>09</td><td>22</td><td>35</td><td>48</td> <td>I</td><td></td><td>2004</td><td>2029</td><td>2054</td> </tr> <tr> <td>10</td><td>23</td><td>36</td><td>49</td> <td>K</td><td></td><td>2005</td><td>2030</td><td>2055</td> </tr> <tr> <td>11</td><td>24</td><td>37</td><td>50</td> <td>L</td><td></td><td>2006</td><td>2031</td><td>2056</td> </tr> <tr> <td>12</td><td>25</td><td>38</td><td>51</td> <td>M</td><td></td><td>2007</td><td>2032</td><td>2057</td> </tr> <tr> <td>13</td><td>26</td><td>39</td><td>52</td> <td>N</td><td></td><td>2008</td><td>2033</td><td>2058</td> </tr> <tr> <td colspan="4" rowspan="13"> <table border="1" style="width: 100%; border-collapse: collapse;"> <tr> <td align="center" colspan="2"> Esempio di composizione. </td> </tr> <tr> <td align="center" colspan="2"> 03P </td> </tr> <tr> <td align="center" colspan="2"> Descrizione: </td> </tr> <tr> <td>03</td><td>Settimana n° 03</td> </tr> <tr> <td>P</td><td>Anno 2010</td> </tr> </table> </td> <td>O</td><td></td><td>2009</td><td>2034</td><td>2059</td> </tr> <tr> <td>P</td><td></td><td>2010</td><td>2035</td><td>2060</td> </tr> <tr> <td>Q</td><td></td><td>2011</td><td>2036</td><td>2061</td> </tr> <tr> <td>R</td><td></td><td>2012</td><td>2037</td><td>2062</td> </tr> <tr> <td>S</td><td>1988</td><td>2013</td><td>2038</td><td>2063</td> </tr> <tr> <td>T</td><td>1989</td><td>2014</td><td>2039</td><td>2064</td> </tr> <tr> <td>U</td><td>1990</td><td>2015</td><td>2040</td><td>2065</td> </tr> <tr> <td>V</td><td>1991</td><td>2016</td><td>2041</td><td>2066</td> </tr> <tr> <td>W</td><td>1992</td><td>2017</td><td>2042</td><td>2067</td> </tr> <tr> <td>X</td><td>1993</td><td>2018</td><td>2043</td><td>2068</td> </tr> <tr> <td>Y</td><td>1994</td><td>2019</td><td>2044</td><td>2069</td> </tr> <tr> <td>Z</td><td>1995</td><td>2020</td><td>2045</td><td>2070</td> </tr> </table>			Posizione 1 e 2: n° della settimana.				Posizione 3: Una lettera per l'anno in corso.				01	14	27	40	A		1996	2021	2046	02	15	28	41	B		1997	2022	2047	03	16	29	42	C		1998	2023	2048	04	17	30	43	D		1999	2024	2049	05	18	31	44	E		2000	2025	2050	06	19	32	45	F		2001	2026	2051	07	20	33	46	G		2002	2027	2052	08	21	34	47	H		2003	2028	2053	09	22	35	48	I		2004	2029	2054	10	23	36	49	K		2005	2030	2055	11	24	37	50	L		2006	2031	2056	12	25	38	51	M		2007	2032	2057	13	26	39	52	N		2008	2033	2058	<table border="1" style="width: 100%; border-collapse: collapse;"> <tr> <td align="center" colspan="2"> Esempio di composizione. </td> </tr> <tr> <td align="center" colspan="2"> 03P </td> </tr> <tr> <td align="center" colspan="2"> Descrizione: </td> </tr> <tr> <td>03</td><td>Settimana n° 03</td> </tr> <tr> <td>P</td><td>Anno 2010</td> </tr> </table>				Esempio di composizione.		03P		Descrizione:		03	Settimana n° 03	P	Anno 2010	O		2009	2034	2059	P		2010	2035	2060	Q		2011	2036	2061	R		2012	2037	2062	S	1988	2013	2038	2063	T	1989	2014	2039	2064	U	1990	2015	2040	2065	V	1991	2016	2041	2066	W	1992	2017	2042	2067	X	1993	2018	2043	2068	Y	1994	2019	2044	2069	Z	1995	2020	2045	2070
Posizione 1 e 2: n° della settimana.				Posizione 3: Una lettera per l'anno in corso.																																																																																																																																																																																																					
01	14	27	40	A		1996	2021	2046																																																																																																																																																																																																	
02	15	28	41	B		1997	2022	2047																																																																																																																																																																																																	
03	16	29	42	C		1998	2023	2048																																																																																																																																																																																																	
04	17	30	43	D		1999	2024	2049																																																																																																																																																																																																	
05	18	31	44	E		2000	2025	2050																																																																																																																																																																																																	
06	19	32	45	F		2001	2026	2051																																																																																																																																																																																																	
07	20	33	46	G		2002	2027	2052																																																																																																																																																																																																	
08	21	34	47	H		2003	2028	2053																																																																																																																																																																																																	
09	22	35	48	I		2004	2029	2054																																																																																																																																																																																																	
10	23	36	49	K		2005	2030	2055																																																																																																																																																																																																	
11	24	37	50	L		2006	2031	2056																																																																																																																																																																																																	
12	25	38	51	M		2007	2032	2057																																																																																																																																																																																																	
13	26	39	52	N		2008	2033	2058																																																																																																																																																																																																	
<table border="1" style="width: 100%; border-collapse: collapse;"> <tr> <td align="center" colspan="2"> Esempio di composizione. </td> </tr> <tr> <td align="center" colspan="2"> 03P </td> </tr> <tr> <td align="center" colspan="2"> Descrizione: </td> </tr> <tr> <td>03</td><td>Settimana n° 03</td> </tr> <tr> <td>P</td><td>Anno 2010</td> </tr> </table>				Esempio di composizione.		03P		Descrizione:		03	Settimana n° 03	P	Anno 2010	O		2009	2034	2059																																																																																																																																																																																							
				Esempio di composizione.																																																																																																																																																																																																					
				03P																																																																																																																																																																																																					
				Descrizione:																																																																																																																																																																																																					
				03	Settimana n° 03																																																																																																																																																																																																				
				P	Anno 2010																																																																																																																																																																																																				
				P		2010	2035	2060																																																																																																																																																																																																	
				Q		2011	2036	2061																																																																																																																																																																																																	
				R		2012	2037	2062																																																																																																																																																																																																	
				S	1988	2013	2038	2063																																																																																																																																																																																																	
				T	1989	2014	2039	2064																																																																																																																																																																																																	
				U	1990	2015	2040	2065																																																																																																																																																																																																	
				V	1991	2016	2041	2066																																																																																																																																																																																																	
W	1992	2017	2042	2067																																																																																																																																																																																																					
X	1993	2018	2043	2068																																																																																																																																																																																																					
Y	1994	2019	2044	2069																																																																																																																																																																																																					
Z	1995	2020	2045	2070																																																																																																																																																																																																					
Reparto competente: Uff. Industrializzazione	Data: 9 aprile 2010	Creato da: Marco Bontempi	Approvato da: Bruno Ghizzardi																																																																																																																																																																																																						

	Operation and maintenance instructions Camozzi internal bus system	5000004823
		Versione 03

2. General recommendations

The recommendations regarding safe use in this document should be observed at all times.

- Some hazards can only be associated with the product after it has been installed on the machine/equipment. It is the task of the final user to identify these hazards and reduced the associated risks accordingly.
- The products dealt with in this manual may be used in circuits that must comply with the standard EN ISO 13849-1.
- For information regarding component reliability, contact Camozzi.
- Before proceeding with use of the product, carefully read all information in this document.
- Conserve this document in a safe place accessible to all personnel throughout the product life cycle.
- This document should accompany the product in the event of transfer to a new owner or user.
- The instructions in this manual must be observed together with the instructions and additional information regarding the product in this manual, available from the following reference links:
 - web site <http://www.camozzi.com>
 - Camozzi general catalogue
 - Technical assistance service
- Assembly and start-up operations must be performed exclusively by qualified and authorized personnel on the basis of these instructions.
- It is the responsibility of the system/machine designer to ensure the correct selection of the most suitable pneumatic component according to the intended application.
- It is recommended to use suitable protections to minimize the risk of physical injury.
- For all situations not contemplated in this manual and in situations in which there is the risk of potential damage to objects, or injury to persons or animals, contact Camozzi for advice.
- Never make unauthorized modifications to the product. In this case, any damage or injury to objects, persons or animals will be the responsibility of the user.
- All relevant product safety standards must be observed at all times.
- Never intervene on the machine/system before verifying that all working conditions are safe.
- Before installation and maintenance, ensure that the specific envisaged safety locks are active, and then disconnect the electrical mains (if necessary) and system pressure supply, discharging all residual compressed air from the circuit and deactivating residual energy stored in springs, condensers, recipients and gravity.
- After installation or maintenance, the system pressure and electrical power supply (if necessary) must be reconnected, after which the operator must check correct operation and sealing efficiency of the product. In the event of sealing failure or malfunction, the product must not be used.

	Operation and maintenance instructions Camozzi internal bus system	5000004823
		Versione 03

- The product may only be used in observance of the specifications provided; if these requirements are not met, the product may only be used on authorization by Camozzi.
- Avoid covering the equipment with paint or other substances that may reduce heat dissipation.

3. General characteristics and conditions of use

General characteristics and conditions of use

Assembly position	Any
Ambient temperature	0 ÷ 50 °C
Ambient humidity	Max 90%
IP protection rating according to EN 60529	IP65 (full system)
Vibrations	In according with CEI EN 61131-2
Continuous shock	In according with CEI EN 61131-2

	Operation and maintenance instructions Camozzi internal bus system	5000004823
		Versione 03

4. Product storage and transport

- Adopt all measures possible to avoid accidental damage to the product during transport, and when available use the original packaging.
- Observe the specified storage temperature range of -10 - 50 °C.

5. System general description

Il Sistema Bus interno (sottorete) Camozzi consente di trasferire fra il modulo CPU e gli elementi ad esso collegati lo stato delle uscite e degli ingressi.

Il sistema nel suo complesso è formato da un Modulo CPU che comunica con un Master tramite bus, da moduli ingresso ed uscita sia analogici che digitali, da moduli adattatori che consentono di collegare in modo solidale all'isola alcune serie di valvole e da moduli che permettono di remotare i moduli sopra. Grazie a questi ultimi, si possono realizzare varie configurazioni della rete: lineare, stella albero o una combinazione di queste tipologie.

Il numero massimo di moduli collegabili è limitato dall'assorbimento massimo di corrente e dal numero massimo di dati che il sistema può gestire: 1024 uscite e 1024 ingressi.

I parametri previsti per i vari moduli sono modificabili tramite il software di configurazione **CX-Configurator** (per maggiori dettagli sull'utilizzo del configuratore e in particolare di questa funzionalità, fare riferimento al manuale "Istruzioni d'uso e manutenzione – CX Configurator").

Per conoscere gli accessori disponibili per questi moduli, fare riferimento al Catalogo Generale Camozzi o contattare la rete vendita Camozzi.

6. Installation and start-up

- check whether there are any fault caused by product transport or storage.
- Separate all packaging material to enable the recovery or disposal in accordance with current standards in the country of use.
- Before operating the component, ensure that the stated specifications and performance correspond to requirements.
- During component installation, ensure suitable voltage overload protection devices are fitted.
- During component installation, ensure that no hazards are generated due to mechanical movements.
- Install the component in an area where the set-up and maintenance phases are easily performed without generating hazards for the operator.
- Close off any connections with suitable safety caps/covers.
- The components must be fixed correctly using, where possible, the specific anchors and ensuring that the fixture remains efficient even when the actuator is repeatedly used at a high frequency and in the presence of strong vibrations.

	Operation and maintenance instructions Camozzi internal bus system	5000004823
		Versione 03

- In the case of strong vibrations envisage suitable devices/systems able to dampen the effect on the component.
- Envisage the installation of dehumidifiers to avoid the formation of humidity or condensation on internal components.
- If the device is used to activate an actuator on which any accidental movement can generate a hazard, envisage suitable locking devices on the mobile section of the actuator.
- Ensure that the connectors are correctly connected and secured.
- To connect both input or output, digital and analog signal, use not shielded cables with maximum length 3 mt.
- Use only power able to ensure a reliable electrical isolation of the supply voltage according to IEC 742 / EN 60742 / VDE 0551 with a minimum strength of 4 kV isolation Protected Extra Low Voltage, PELV.
- The user must take the necessary measures to prevent damage to the system caused by non-periodic overvoltage spikes on the power lines produced by power break to high-energy equipment.
- The voltage interruptions are permitted according to the severity level PS2.
- About electromagnetic compatibility, the modules is designed to work in area A.
- About modules with a power supply connector (POWER) refer to the recommendation listed on the CPU module manual: electrical protection, nominal tension and tolerance, maximum cable length in order to avoid too big voltage drop.
- To improve immunity to disturbance and prevent damage, it is recommended to connect the device to the circuit earthing system using any one of the holes on the aluminium body.
- For configuration of the CPU module and the connected modules, download the set-up file of the software **CX-Configurator** from the web site <http://www.camozzi.com> and proceed with installation according to the instructions on screen displayed during the process. For more details, please refer to the "**Operating and Maintenance Instructions - CX Configurator**".
- Before starting up the configuration software **CX-Configurator**, connect the module to the PC using a standard USB cable (is available the accessory G11W-G12W-2), then connect the electrical power supply via connector M12. The CPU module is fitted with a Micro USB connector under the transparent panel. To access the connector, remove the transparent panel by loosening the screw securing it to the cover of the module. After completing all settings, exit the software **CX-Configurator**, remove the USB cable and re-fit the transparent panel to restore the specified IP protection rating. During the normal use of this products, disconnect cables or devices from the USB port. Use the USB port only for setting or service.
- On start-up of the software **CX-Configurator** the system verifies communication between the device and the PC where the configuration software is installed. In the event of communication failure, an error message is displayed.

	Operation and maintenance instructions Camozzi internal bus system	5000004823
		Versione 03

Type of fault	Causes	Remedy
Communication failure between CPU module and PC	Electrical power supply not connected	Connect the Electrical power supply by means of the M12 connector POWER.
	USB cable not connected	Connect the USB cable to one of the ports available on the PC and to the Micro USB connector under the transparent panel on the device.
	USB drivers not installed	Contact the Camozzi technical assistance service.

7. ME3-0800-DC: 8 PNP digital input I/O module



- **Electrical circuit**

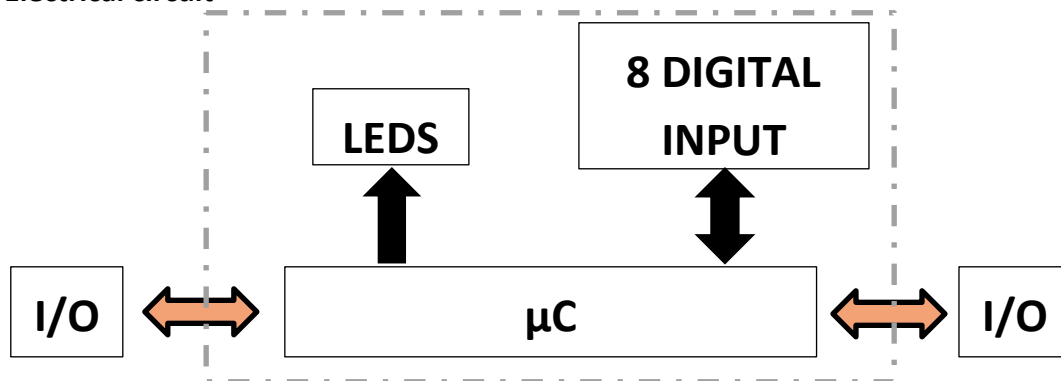

- **Pinout:** each of the 8 connectors M8 3 poles female have the same pinout:

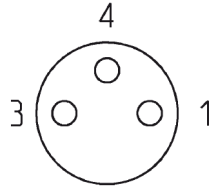
INPUT connector			
Pin	Signal	Description	
1	VCC	24Vdc power supply provided from the module outside	
3	GND	Reference	
4	Input	Input (max 100mA each input)	

The VCC signals are connected together for the inputs 1, 3, 5 and 7 and for the inputs 2, 4, 6 and 8.

The GND signals are connected together for all inputs.

The VCC and GND signals must not be connected to each other's: the card may damage.

In the case of 2-wire sensors, connect the brown wire (positive) to pin 1 and the blue wire (load) to pin 4.

In the case of 3-wire sensors, connect the brown wire (positive) to pin 1, the blue wire (negative) to pin 3 and the black wire (load) to pin 4.

- **Characteristics**

Characteristics

Weight	Approximately 120 gr
Input polarity	PNP
N° of input	8 digital optoisolated
Electrical connection	M8 3 poles female for each input
Dimensions	L = 122 mm; W = 25 mm
Signalling Led	Yellow Led for each input
Overload protection	Overall 400 mA for inputs 1, 3, 5 e 7 Overall 400 mA for inputs 2, 4, 6 e 8
Current consumption without load	Approximately 30 mA
Material	Alluminium
Operating range	Type 1 (related to CEI EN 61131-2 article 5.2.1.2)

- **Data exchange:** each module, with factory settings, send 8 bits (1 byte) input data. This number of bits may be decreased (up to 0 bit) via the software configurator **CX-Configurator** (for more details on using the configurator and especially about this feature, refer to the manual **“Operation and maintenance instructions – CX Configurator”**).

According to the following table, each input matches with a bit. Is not possible to change this correspondence:

Byte 0							
Bit 7	Bit 6	Bit 4	Bit 4	Bit 3	Bit 2	Bit 1	Bit 0
Input n° 8	Input n° 7	Input n° 6	Input n° 5	Input n° 4	Input n° 3	Input n° 2	Input n° 1

- **Parameters:**

It is possible to modify the following parameters via the software configurator **CX-Configurator** (for more details on using the configurator and especially about this feature, refer to the manual **“Operation and maintenance instructions – CX Configurator”**).

Debounce time [ms]: it represents the minimum duration of the signal to be valid. If the signal is shorten than this value, the value of associated bit do not change. Factory setting: 5 ms.

Extension time [ms]: it represent the minimum duration of the signal. If the signal is valid (period greather than debounce time) but shorten than extended time value, its period is extended to this value. Factory setting: 50 ms.

8. ME3-0400-DC: 4 PNP digital input I/O module

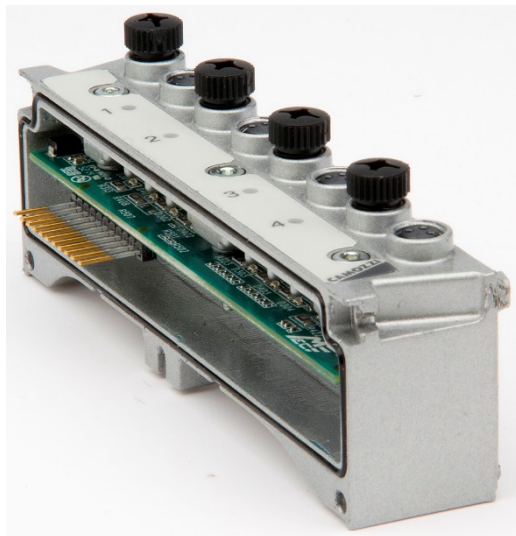

- **Electrical circuit**

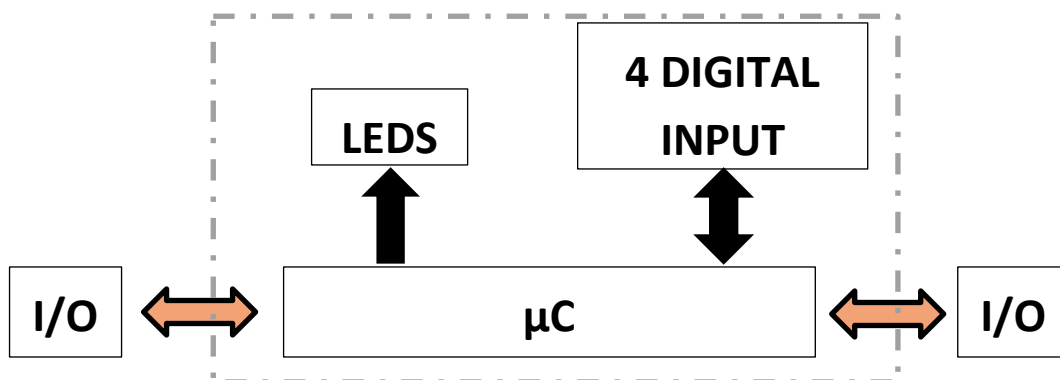

- **Pinout:** each of the 4 connectors M8 3 poles female have the same pinout:

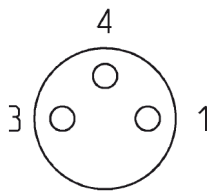
INPUT connector			
Signal	Signal	Descrizione	
VCC	VCC	Alimentazione 24Vdc fornita dal modulo all'esterno	
GND	GND	Riferimento	
Input	Input	Ingresso (max 100mA per ogni ingresso)	

The VCC signals are connected together for for all inputs.

The GND signals are connected together for all inputs.

The VCC and GND signals must not be connected to each other's: the card may damage.

In the case of 2-wire sensors, connect the brown wire (positive) to pin 1 and the blue wire (load) to pin 4.

In the case of 3-wire sensors, connect the brown wire (positive) to pin 1, the blue wire (negative) to pin 3 and the black wire (load) to pin 4.

	Operation and maintenance instructions Camozzi internal bus system	5000004823
		Versione 03

- **Characteristics**

Characteristics

Weight	Approximately 120 gr
Input polarity	PNP
N° of input	4 digital optoisolated
Electrical connection	M8 3 poles female for each input
Dimensions	L = 122 mm; W = 25 mm
Signalling Led	Yellow Led for each input
Overload protection	Overall 400 mA
Current consumption without load	Approximately 25 mA
Material	Alluminium
Operating range	Type 2 (related to CEI EN 61131-2 article 5.2.1.2)

- **Data exchange:** each module, with factory settings, send 8 bits (1 byte) input data. This number of bits may be decreased (up to 0 bit) via the software configurator **CX-Configurator** (for more details on using the configurator and especially about this feature, refer to the manual “**Operation and maintenance instructions – CX Configurator**”).
According to the following table, only the 4 Less Significant Bits matches with an input and is not possible to change this correspondence; the others 4 bits do not matches with inputs:

Byte 0							
Bit 7	Bit 6	Bit 5	Bit 4	Bit 3	Bit 2	Bit 1	Bit 0
N.U.	N.U.	N.U.	N.U.	Input n° 4	Input n° 3	Input n° 2	Input n° 1

- **Parameters:**

It is possible to modify the following parameters via the software configurator **CX-Configurator** (for more details on using the configurator and especially about this feature, refer to the manual “**Operation and maintenance instructions – CX Configurator**”).

Debounce time [ms]: it represents the minimum duration of the signal to be valid. If the signal is shorten than this value, the value of associated bit do not change. Factory setting: 5 ms.

Extension time [ms]: it represent the minimum duration of the signal. If the signal is valid (period greater than debounce time) but shorten than extended time value, its period is extended to this value. Factory setting: 50 ms.

9. ME3-0004-DL: 4 NPN digital output I/O module

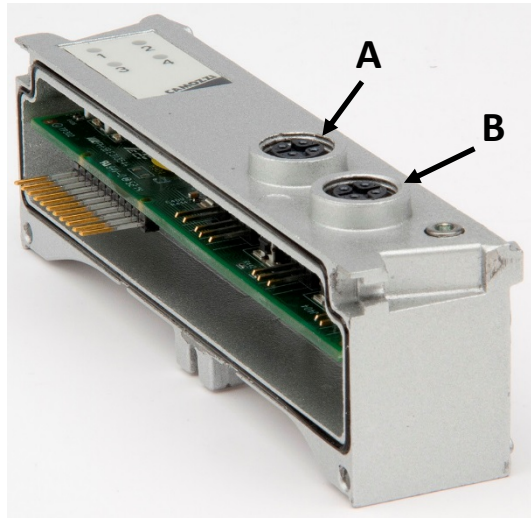

- Electrical circuit

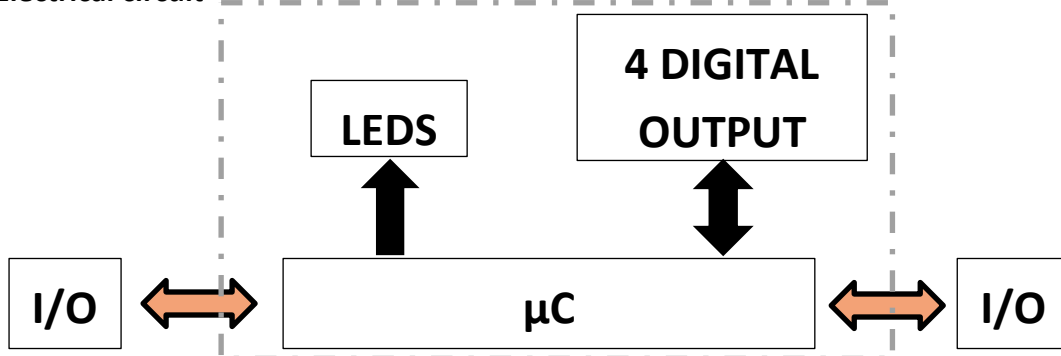

- Pinout:** each of the 2 connectors M12 5 poles female have the following pinout:

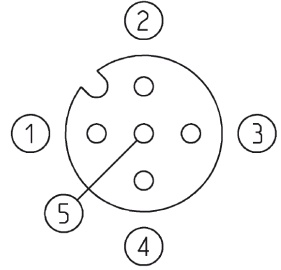
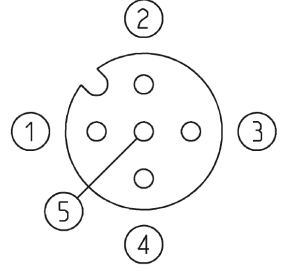
OUTPUT A connector			
Pin	Signal	Description	
1	VCC	24Vdc power supply provided from the module outside	
2	Output +1	Output 2 (reference pin 1)	
3	GND	Common (reference pin 1)	
4	Output	Output 1 (reference pin 1)	
5	EARTH	Earth connection	
OUTPUT B connector			
Pin	Signal	Description	
1	VCC	24Vdc power supply provided from the module outside	
2	Output +1	Output 4 (reference pin 1)	
3	GND	Common (reference pin 1)	
4	Output	Output 3 (reference pin 1)	
5	EARTH	Earth connection	

	Operation and maintenance instructions Camozzi internal bus system	5000004823
		Versione 03

The VCC signals are connected together.

Don't connect the VCC signal with the GND signal and don't connect them with the signals Output and Output+1: the card may be damaged.

If the load has a polarity but doesn't require a power supply, connect the positive pole to pin 1 and connect the negative pole to pin 2 or 4.

If the load requires a power supply, connect also the positive pole of power supply to pin 1 and connect the negative pole of power supply to pin 3.

- **Characteristics**

Characteristics	
Weight	Approximately 100 gr
Input polarity	NPN
N° of input	4 digital NO (semiconductors)
Electrical connection	M12 5 poles female (2 outputs each connector)
Dimensions	L = 122 mm; W = 25 mm
Signalling Led	Yellow Led for each output. Fixed when the output is ON, blinking when a short-circuit is present.
Overload protection	10W each output or 20W each connector
Current consumption without load	Approximately 10 mA
Material	Alluminium

- **Data exchange:** each module, with factory settings, sends 8 bits (1 byte) of output data. This number of bits may be decreased (up to 0 bits) via the software configurator **CX-Configurator** (for more details on using the configurator and especially about this feature, refer to the manual "**Operation and maintenance instructions – CX Configurator**").

According to the following table, only the 4 Least Significant Bits match with an output, the other 4 bits do not match with outputs.

It is possible to modify the correspondence bit-output via the software configurator **CX-Configurator** (for more details on using the configurator and especially about this feature, refer to the manual "**Operation and maintenance instructions – CX Configurator**").

Byte 0							
Bit 7	Bit 6	Bit 5	Bit 4	Bit 3	Bit 2	Bit 1	Bit 0
N.U.	N.U.	N.U.	N.U.	Output n° 4	Output n° 3	Output n° 2	Output n° 1

	Operation and maintenance instructions Camozzi internal bus system	5000004823
		Versione 03

- **Parameters:**

It is possible to modify the following parameters via the software configurator **CX-Configurator** (for more details on using the configurator and especially about this feature, refer to the manual “**Operation and maintenance instructions – CX Configurator**”).

PWM activation: it is possible to activate the PWM modulation for the digital output. If this parameter is set, the 4 output of the module work in this mode with the same PWM value: PWM inrush time, PWM frequency and PWM duty cycle. Factory setting: OFF.

PWM inrush time: if the PWM activation parameter is set, it is possible to set the inrush time (initial period time with the output value fixed to ON). The value is selectable from a list [ms]: 0, 3, 5, 10, 15, 20, 30, 50, 80, 110, 140, 170, 200, 230, 260 e 300. Factory setting: 0 ms.

PWM duty cycle and frequency: if the PWM activation parameter is set, it is possible to set the output duty cycle and frequency. The value of duty cycle is selectable in the following table, the value of frequency isn't modifiable by the user but is automatically set in according to the following table.

Duty cycle [%]	0	12,5	25	37,5	50	62,5	75	87,5
Frequency [kHz]	0		12,5		25		50	

Factory setting: duty cycle 0% (frequency 0 kHz)..

Failsafe: it is possible to set the output value (ON/OFF) in case of communication error. Factory setting: the output value don't change.

10. 2 channel analog I/O module

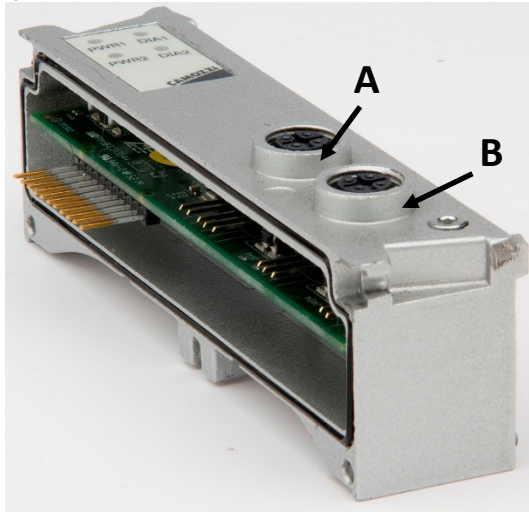

- Electrical circuit

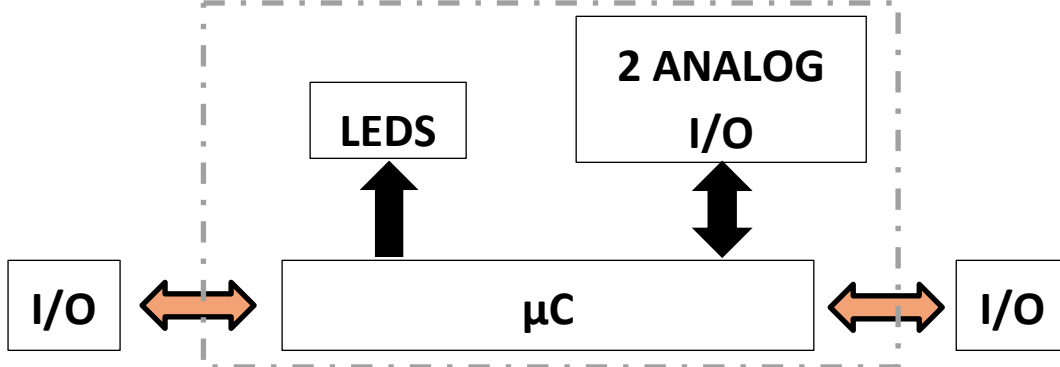

- Pinout:** each of the 2 connectors M12 5 poles female have the following pinout:

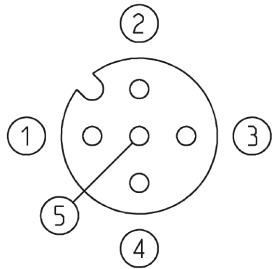
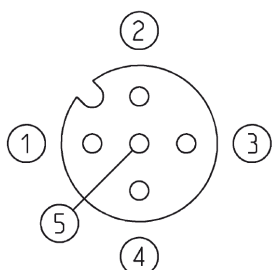
ANALOG A connector			
Pin	Signal	Description	
1	VCC	24Vdc power supply provided from the module outside	
2	IN/OUT	Input/Output 1 (see coding table)	
3	GND_VCC	Common power supply (reference pin 1)	
4	GND_Output	Reference pin 2. If the channel is set as OUT, pins 3 and 4 are internally connected to each other's.	
5	EARTH	Earth connection	
ANALOG B connector			
Pin	Signal	Description	
1	VCC	24Vdc power supply provided from the module outside	
2	IN/OUT	Input/Output 2 (see coding table)	
3	GND_VCC	Common power supply (reference pin 1)	
4	GND_Output	Reference pin 2. If the channel is set as OUT, pins 3 and 4 are internally connected to each other's.	
	EARTH	Earth connection	

- **Collegamento con sensori passivi**

In caso di sensori passivi, cortocircuitare fra di loro i pin 3 e 4 e collegare i pin 1 e 2 al sensore rispettando le polarità.

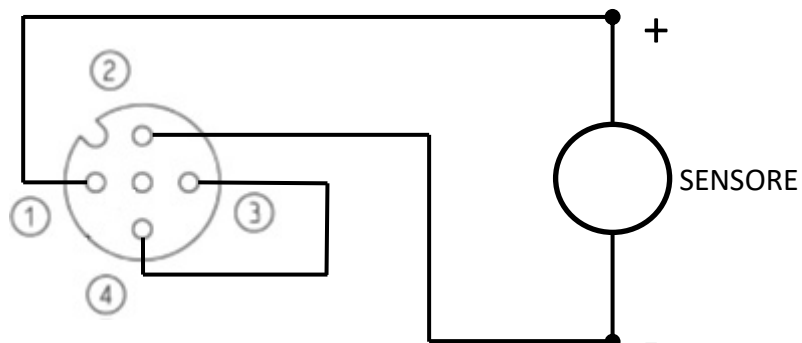

- **Collegamento con sensori attivi**

In caso di sensori attivi, che necessitano di ricevere un'alimentazione elettrica esterna, e collegare i pin 2 e 4 al sensore rispettando le polarità. Per alimentare il sensore attraverso il modulo, collegare anche i pin 1 e 3 al sensore rispettando le polarità; se invece si vuole usare un alimentatore esterno, lasciare i pin 1 e 3 scollegati.

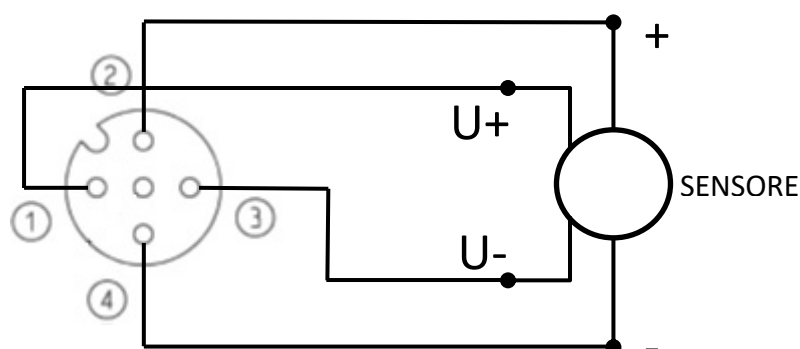

- **NOTE:** Pin 1 (VCC) and pin 2 (Analog IN or OUT) are connected to the logic power supply (L24) of the CPU module (or of the CX99-0-0 expansion module) to which this module is connected. By removing only the power supply (P24) from the CPU module (or from the CX99-0-0 expansion module), the 24V voltage remains present on pin 1 (VCC) of the analog module and also the analog value (pin 2 analog IN or OUT) doesn't change.







- **Characteristics**

Characteristics

Weight	Approximately 100 gr
Input polarity	-
N° of I/O	2 analog
Electrical connection	M12 5 poles female
Ingombri	L = 122 mm; W = 25 mm
Signalling Led	Red Led DIA each I/O Green Led PWR each I/O
Overload protection	500 mA each I/O
Current consumption without load	Approximately 20 mA
Material	Alluminium
Maximum resolution	12 bit on the range 0-10V and 0-20mA
Signal range	0-10V 4-20 mA
Input impedance	10KΩ voltage input; 35Ω current input
Output impedance	780KΩ voltage output; <600Ω current output
Analog input and analog error in relation to the temperature	±0, 0,0126%/°C voltage input; ±0,0004%/°C voltage output ±0,0016%/°C current input; ±0,003%/°C current output
Interference between the analog channels	0,1%
Analog input non-linearity	0,27% for current; 0,57% for voltage
Analog input ripetibility	0,45% for current; 0,2% for voltage
Analog output non-linearity	0,15% for current; 0,6% for voltage
Analog output ripetibility	0,00015% for current; 0,00003% for voltage
Analog output stabilization time	240μs
Analog output overshoot	0

	Operation and maintenance instructions Camozzi internal bus system	5000004823
		Versione 03

- **Signalling LED:**

PWR	Problem	Solution
 Fixed	The voltage Vcc is present.	
 Off	The voltage Vcc is not present.	Verify if is present a short circuit.
DIA	Problem	Solution
 75% ON - 25% OFF	The voltage Vcc have a value less than 19,5V.	Verify the value of L24V voltage on the power connector of the island.
 50% ON - 50% OFF	The voltage P24V is not present.	Verify the connection on the the power connector of the island.
 25% ON - 75% OFF	The voltage P24V have a value less than 19,5V.	Verify the value of P24V voltage on the power connector of the island
 Off	No error.	

- **Versions:** the following version are available relating the function of the two I/O channel.

CODICE	CHANNEL 1 FUNCTION (CONNECTOR "A")	CHANNEL 2 FUNCTION (CONNECTOR "B")
ME3-00R0-AL	OUT 4-20 mA	OUT 4-20 mA
ME3-00T0-AL	OUT 0-10 V	OUT 0-10 V
ME3-C000-AL	IN 4-20 mA	IN 4-20 mA
ME3-D000-AL	IN 0-10 V	IN 0-10 V
ME3-00U0-AL	OUT 4-20 mA	OUT 0-10 V
ME3-E000-AL	IN 4-20 mA	IN 0-10 V
ME3-00V0-AL	IN 0-10 V	OUT 4-20 mA
ME3-00Z0-AL	IN 4-20 mA	OUT 4-20 mA
ME3-00K0-AL	IN 0-10 V	OUT 0-10 V
ME3-00Y0-AL	IN 4-20 mA	OUT 0-10 V

	Operation and maintenance instructions Camozzi internal bus system	5000004823
		Versione 03

- **Data exchange:** refer the resolution parameter.
- **Parameters:**

It is possible to modify the following parameters via the software configurator **CX-Configurator** (for more details on using the configurator and especially about this feature, refer to the manual “**Operation and maintenance instructions – CX Configurator**”).

Activation channel: it is possible enable/disable every analog channel. If a channel is disable, its output is zero. Factory setting: enable.

Filter: if the channel is set as analog input, it is possible to use a digital filter in order to remove any noises. Attention: to use a too strong filter reduce the signal dynamic. The filter range for every channel is 0 -255 and the value can be different for each channel. Factory setting: 128.

Resolution: for each analog channel it is possible to set a different value of resolution: 12 bit or 8 bit. If the resolution is set to **12 bit**, the analog module send 16 bits (2 bytes) of input data if the channel is set as input or receive 16 bits (2 bytes) of output data if the channel is set as output.

Only the 12 most significant bits are used, the other 4 bits are fixed to 0. The range of every channel with 12-bit resolution is 0 e 65.520 and the step is 16.

BYTE 1								BYTE 0							
BIT 7	BIT 6	BIT 5	BIT 4	BIT 3	BIT 2	BIT 1	BIT 0	BIT 7	BIT 6	BIT 5	BIT 4	BIT 3	BIT 2	BIT 1	BIT 0
MSB											LSB	0	0	0	0
WORD															

NOTE: in the case of controllers using LITTLE-ENDIAN memory, BYTE 0 is read as the most significant and vice versa BYTE 1 is the least significant: to correctly read the data you need to reverse the order of the two bytes (typically the PLCs available for SWAP functions).

BIG ENDIAN	BYTE 1	BYTE 0
LITTLE ENDIAN	BYTE 0	BYTE 1

If the resolution is set to **8 bit**, the analog module send 8 bits (1 byte) of input data if the channel is set as input or receive 8 bits (1 byte) of output data if the channel is set as output. The range of every channel with 8-bit resolution is 0 e 255 and the step is 1.

BYTE 0							
BIT 7	BIT 6	BIT 5	BIT 4	BIT 3	BIT 2	BIT 1	BIT 0
MSB							LSB
BYTE							

	Operation and maintenance instructions Camozzi internal bus system	5000004823
		Versione 03

For each analog channel it is possible to set a different value of resolution. Factory setting: 12 bits.

Failsafe: for each channel set as analog output, it is possible to set the output value in case of communication error. Factory setting: the output value doesn't change.

11.ME3-003P-DI: Valve island series 3 direct interface module

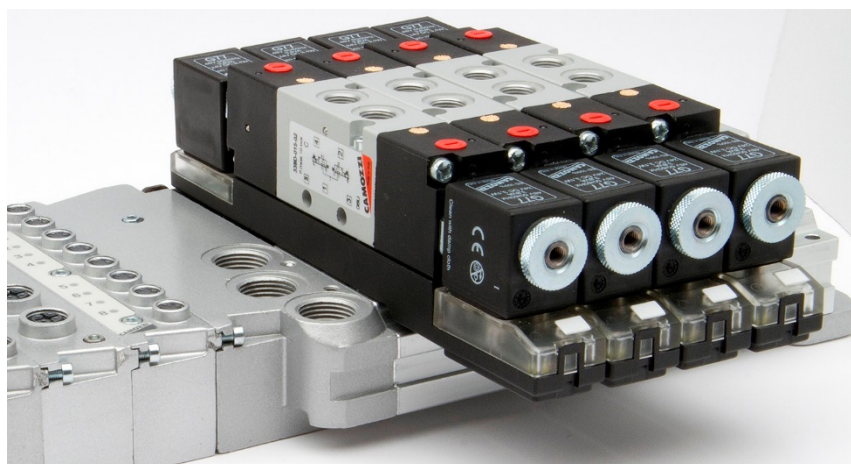

- Electrical circuit

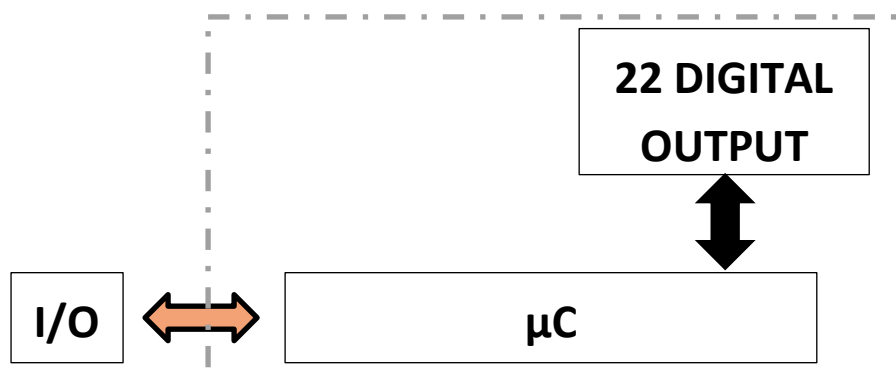

- Characteristics

Characteristics	
Weight	Approximately 245 gr
Output polarity	PNP
Number of output	22 digital NA (semiconductors)
Electrical connection	-
Dimensions	L = 140 mm; W = 45 mm
Signalling Led	-
Overload protection	Shortcircuit protection
Current consumption without load	Approximately 10 mA
Material	Aluminium

	Operation and maintenance instructions Camozzi internal bus system	5000004823
		Versione 03

- The device can be connected to DIN rails using the relative elements PCF-E520 fitted on the rear of the body.
- **Data exchange:** each module, with factory settings, send 24 bits (3 bytes) output data. This number of bits may be decreased (up to 0 bit) via the software configurator **CX-Configurator** (for more details on using the configurator and especially about this feature, refer to the manual “**Operation and maintenance instructions – CX Configurator**”).

According to the following table, only the 22 Less Significant Bits matches with an output, the others 2 bits do not matches with outputs.

It is possible to modify the correspondence bit-output via the software configurator **CX-Configurator** (for more details on using the configurator and especially about this feature, refer to the manual “**Operation and maintenance instructions – CX Configurator**”):

Byte 0							
Bit 7	Bit 6	Bit 5	Bit 4	Bit 3	Bit 2	Bit 1	Bit 0
Out n° 8	Out n° 7	Out n° 6	Out n° 5	Out n° 4	Out n° 3	Out n° 2	Out n° 1
Byte 1							
Bit 7	Bit 6	Bit 5	Bit 4	Bit 3	Bit 2	Bit 1	Bit 0
Out n° 16	Out n° 15	Out n° 14	Out n° 13	Out n° 12	Out n° 11	Out n° 10	Out n° 9
Byte 2							
Bit 7	Bit 6	Bit 5	Bit 4	Bit 3	Bit 2	Bit 1	Bit 0
N.U.	N.U.	Out n° 22	Out n° 21	Out n° 20	Out n° 19	Out n° 18	Out n° 17

- **Parameters:**
It is possible to modify the following parameters via the software configurator **CX-Configurator** (for more details on using the configurator and especially about this feature, refer to the manual “**Operation and maintenance instructions – CX Configurator**”).

Failsafe: it is possible to set the output value (ON/OFF) in case of communication error.
Factory setting: the output value don't change.

- **Correspondence bit versus coils**

The following figures show the various sub-bases and the relative bits (the first number is the byte and the second is the bit) that control the coils.

Sub-bases code	Description	N° of bit busy
A	Intermediate bistable module 2 positions	4
B	Intermediate bistable module 3 positions	6
C	Intermediate monostable module 2 positions	2
D	Intermediate monostable module 3 positions	3

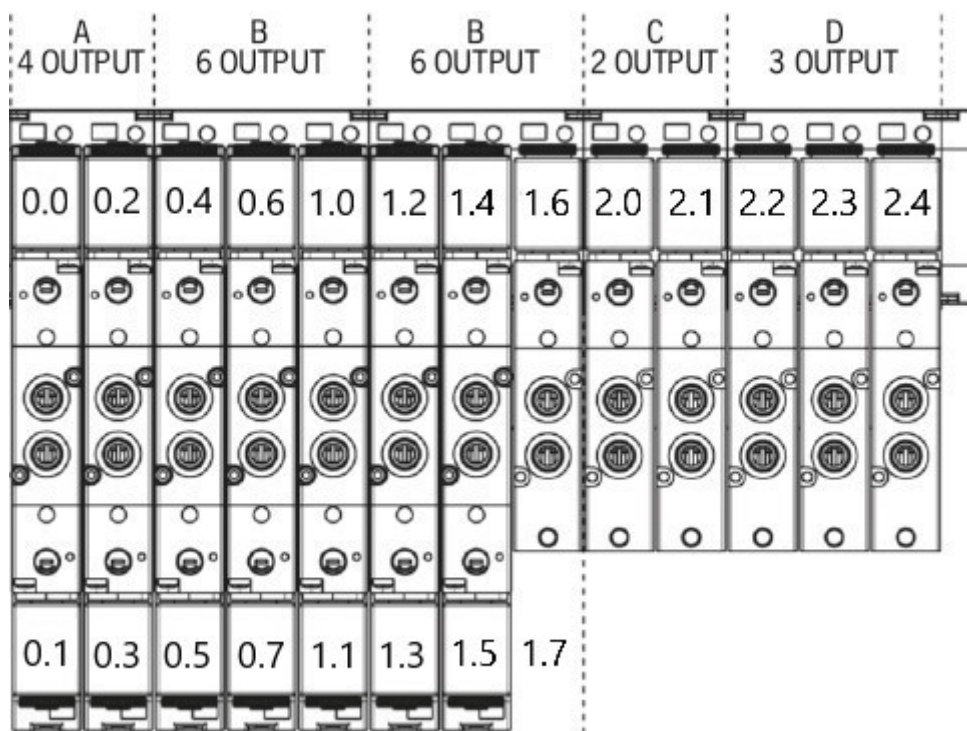

The sub-bases A and B, being bistable modules, always occupy 2 bits for each valve position regardless if the valve mounted above it is monostable or bistable. Instead the sub-bases C and D, being monostable modules, always occupy 1 bit for each valve position.

12.ME3-00F0-DI: Valve island series F1 and F2 direct interface module

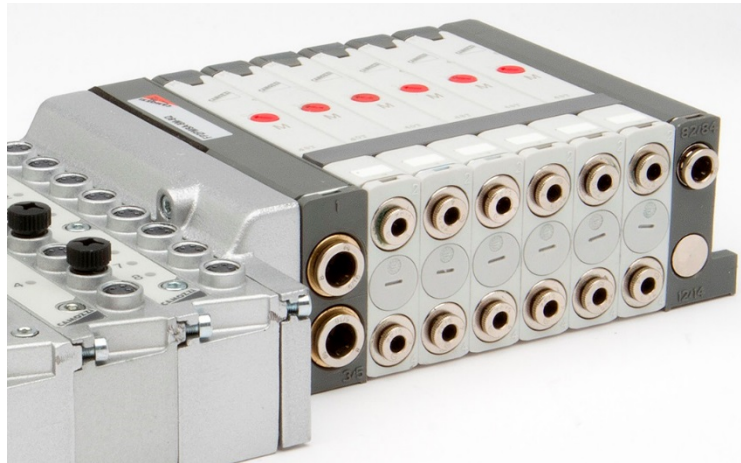

- Electrical circuit

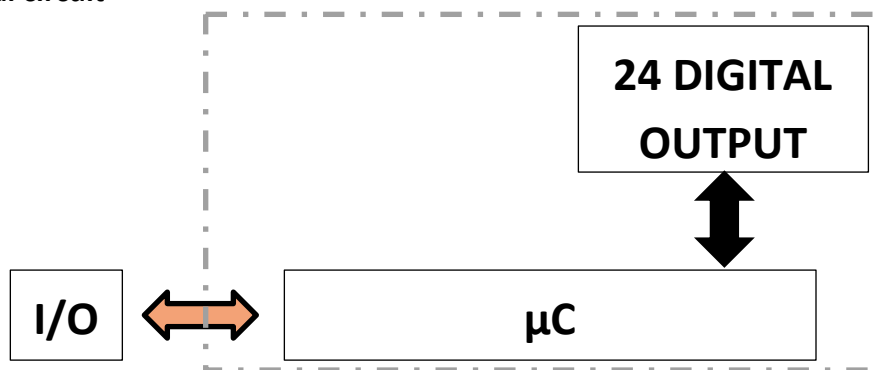

- Characteristics

Characteristics

Weight	Approximately 120 gr
Output polarity	PNP
Number of output	24 digital NA (semiconductors)
Electrical connection	-
Dimensions	L = 122 mm; W = 20 mm
Signalling Led	-
Overload protection	Shortcircuit protection
Current consumption without load	Approximately 10 mA
Material	Aluminium

	Operation and maintenance instructions Camozzi internal bus system	5000004823
		Versione 03

- **Data exchange:** each module, with factory settings, send 24 bits (3 bytes) output data. This number of bits may be decreased (up to 0 bit) via the software configurator **CX-Configurator** (for more details on using the configurator and especially about this feature, refer to the manual “**Operation and maintenance instructions – CX Configurator**”).

According to the following table, each bits matches with an output.

It is possible to modify the correspondence bit-output via the software configurator **CX-Configurator** (for more details on using the configurator and especially about this feature, refer to the manual “**Operation and maintenance instructions – CX Configurator**”):

Byte 0							
Bit 7	Bit 6	Bit 5	Bit 4	Bit 3	Bit 2	Bit 1	Bit 0
Out n° 8	Out n° 7	Out n° 6	Out n° 5	Out n° 4	Out n° 3	Out n° 2	Out n° 1
Byte 1							
Bit 7	Bit 6	Bit 5	Bit 4	Bit 3	Bit 2	Bit 1	Bit 0
Out n° 16	Out n° 15	Out n° 14	Out n° 13	Out n° 12	Out n° 11	Out n° 10	Out n° 9
Byte 2							
Bit 7	Bit 6	Bit 5	Bit 4	Bit 3	Bit 2	Bit 1	Bit 0
Out n° 24	Out n° 23	Out n° 22	Out n° 21	Out n° 20	Out n° 19	Out n° 18	Out n° 17

- **Parameters:**

It is possible to modify the following parameters via the software configurator **CX-Configurator** (for more details on using the configurator and especially about this feature, refer to the manual “**Operation and maintenance instructions – CX Configurator**”).

Failsafe: it is possible to set the output value (ON/OFF) in case of communication error. Factory setting: the output value don't change.

- **Correspondence bit versus coils**

Tipo di valvola	Descrizione	N° bit occupati
M	5/2 Monostable	1
D	5/2 Monostable	2
B	5/2 Bistable	2
C	2 x 3/2 NC	2
A	2 x 3/2 NO	2
G	3/2 NC + 3/2 NO	2
E	2 x 2/2 NC	2
F	2 x 2/2 NO	2
I	2/2 NC + 2/2 NO	2
V	5/3 CC	2
L	Free position	0
W	Free position	2
Z	Free position	1

The following figures show the various valves and the relative bits (the first number is the byte and the second is the bit) that control the coils.

Byte.Bit														
0.0	0.2	0.4		0.6	1.0	1.2	1.3	1.5	1.7	2.1	2.3	2.4	2.5	2.7
0.1	0.3	0.5		0.7	1.1		1.4	1.6	2.0	2.2			2.6	

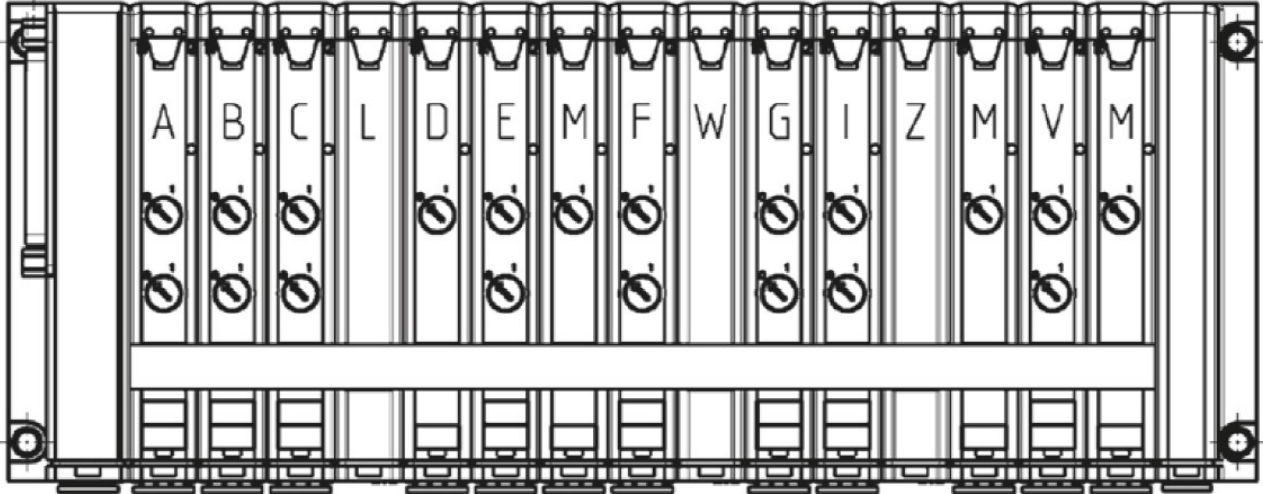

13.Valve island series HN direct interface module

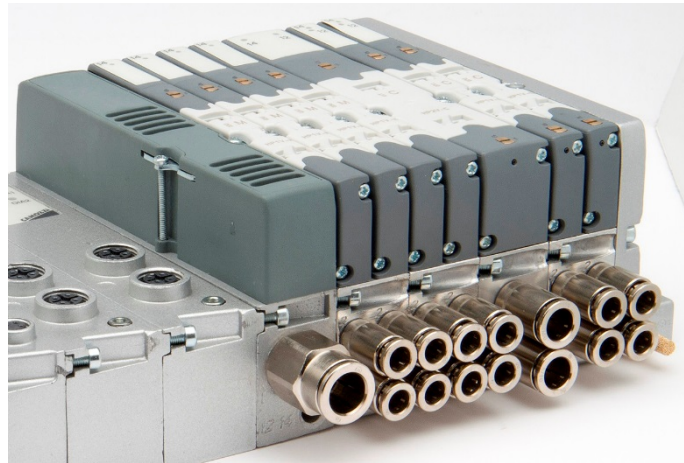

- Electrical circuit

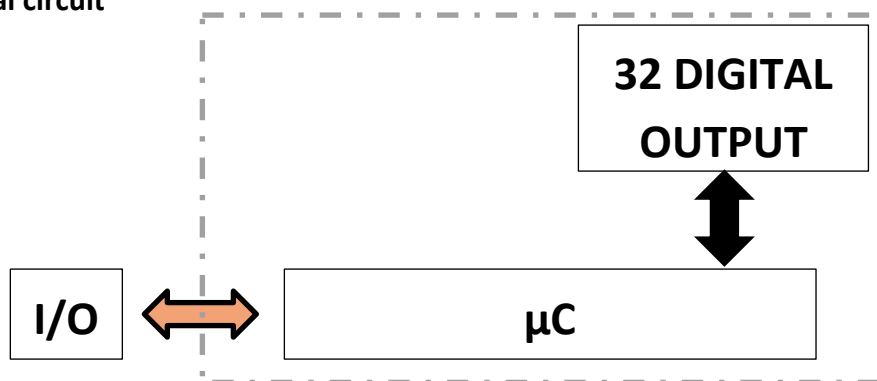

- Characteristics

Characteristics

Weight	Approximately 145 gr
Output polarity	NPN
Number of output	32 digital NA (semiconductors)
Electrical connection	-
Dimensions	L = 122 mm; W = 23 mm
Signalling Led	-
Overload protection	Shortcircuit protection
Current consumption without load	Approximately 15 mA
Material	Aluminium

	Operation and maintenance instructions Camozzi internal bus system	5000004823
		Versione 03

- **Versions:** the following version are available relating the pilot air supply.

CODE	
HA01-000	Series H direct interface module with 12/14 connected
HA02-000	Series H direct interface module with 12/14 separated

- **Dara exchange:** each module, with factory settings, send 32 bits (4 bytes) output data. This number of bits may be decreased (up to 0 bit) via the software configurator **CX-Configurator** (for more details on using the configurator and especially about this feature, refer to the manual “**Operation and maintenance instructions – CX Configurator**”).

According to the following table, each bits matches with an output.

It is possible to modify the correspondence bit-output via the software configurator **CX-Configurator** (for more details on using the configurator and especially about this feature, refer to the manual “**Operation and maintenance instructions – CX Configurator**”):

Byte 0							
Bit 7	Bit 6	Bit 5	Bit 4	Bit 3	Bit 2	Bit 1	Bit 0
Out n° 8	Out n° 7	Out n° 6	Out n° 5	Out n° 4	Out n° 3	Out n° 2	Out n° 1
Byte 1							
Bit 7	Bit 6	Bit 5	Bit 4	Bit 3	Bit 2	Bit 1	Bit 0
Out n° 16	Out n° 15	Out n° 14	Out n° 13	Out n° 12	Out n° 11	Out n° 10	Out n° 9
Byte 2							
Bit 7	Bit 6	Bit 5	Bit 4	Bit 3	Bit 2	Bit 1	Bit 0
Out n° 24	Out n° 23	Out n° 22	Out n° 21	Out n° 20	Out n° 19	Out n° 18	Out n° 17
Byte 3							
Bit 7	Bit 6	Bit 5	Bit 4	Bit 3	Bit 2	Bit 1	Bit 0
Out n° 32	Out n° 31	Out n° 30	Out n° 29	Out n° 28	Out n° 27	Out n° 26	Out n° 25

- **Parameters:**

It is possible to modify the following parameters via the software configurator **CX-Configurator** (for more details on using the configurator and especially about this feature, refer to the manual “**Operation and maintenance instructions – CX Configurator**”).

Failsafe: it is possible to set the output value (ON/OFF) in case of communication error. Factory setting: the output value don't change.

- **Correspondence bit versus coils**

The following figures show the various sub-bases and the relative bits (the first number is the byte and the second is the bit) that control the coils.

SIZE 21 mm (HN2H):

The first two valves use always 4 bit each, the following valves use always 2 bit each, regardless if the valve mounted above it is monostable or bistable.

HN2H-000-14S-MV4MCM4BM-D

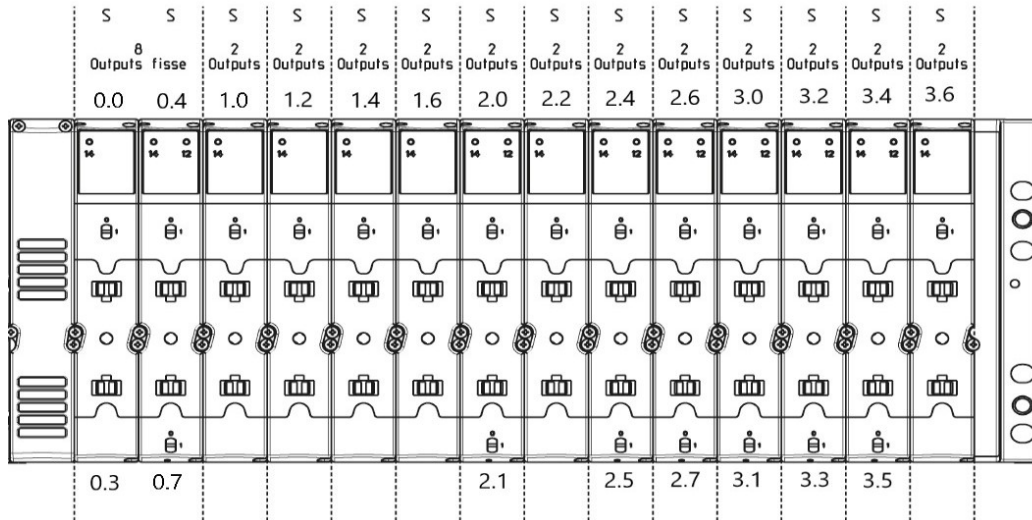

SIZE 10 mm (HN1H):

The first four valves use always 2 bit each, regardless if the valve mounted above it is monostable or bistable.

The following valves use 2 bit each if the sub-base is bistable or 1 bit each if the sub-base is monostable (the name of monostable sub-base finish with Z char, for example AZ, BZ, CZ, ...).

HN1H-000-7C2CZ-2M2B5M5C4M-D

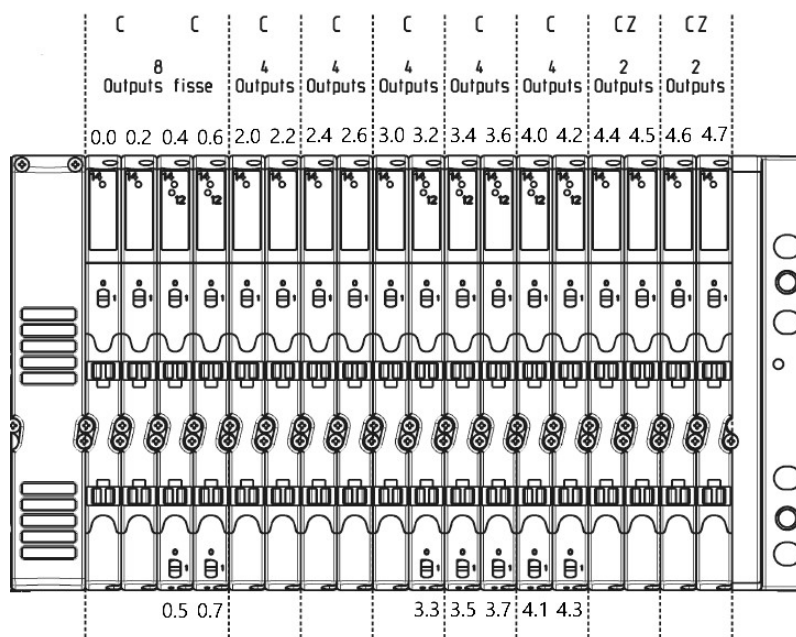

SIZE mixed (HN5H):

On the first two sub-base, the valves size 21 mm use always 4 bit each and the valves size 10 mm use always 2 bit each, regardless if the valve mounted above it is monostable or bistable. On the following sub-bases, the valves size 21 mm use always 2 bit each, the valves size 10 mm use 2 bit each if the sub-base is bistable or 1 bit each if the sub-base is monostable (the name of monostable sub-base finish with Z char, for example AZ, BZ, CZ, ...)

HN5M-000-SC2SC2CZ2S-2M2BMC5M2B-D

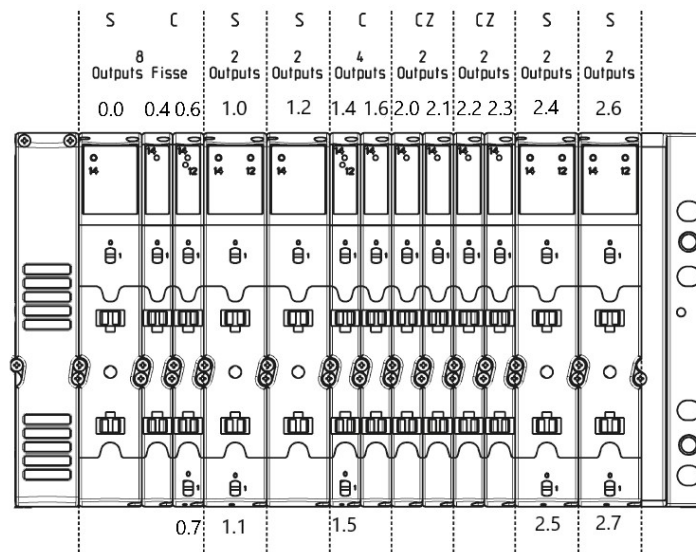

POWER SUPPLY SEPARATOR MODULE

By inserting one or more MSA power supply separation modules (code HA0R-K for the version with terminal block; HA0R-KZ for the version with M12A male connector) between the intermediate modules of the Series HN, it is possible to create separate power supply zones on the valve island, in order to interrupt the operation of a part of the valves on the island, while the rest of the valves operate normally.

It is possible to insert an MSA module only after the second pneumatic sub-base, for both size 10 and 21.

The MSA modules interrupt the + 24VDC positive pole line inside the valve island you need to connect them all to a + 24VDC positive pole of the power supply, which must come from the same source of power supply that supplies the CPU module or the expansion module CX99-0-0 of the valve island to which they are connected. The initial module or the CX99-0-0 expansion module and all MSA modules must therefore be supplied by the same power supply (or by multiple power supplies with the negative poles connected).

In order for the MSA modules to work properly, the power supply (P24) must not be disconnected from the CPU module or the CX99-0-0 expansion module of the valve island to which they are connected. Therefore, it is not possible to turn off the valves (V1) positioned

on the island between the CPU module or the CX99 expansion module and the first MSA module (switch A in OFF position) and at the same time keep other valves (V2 and/or V3) on through an MSA of the same valve island (switches B and/or C in ON position).

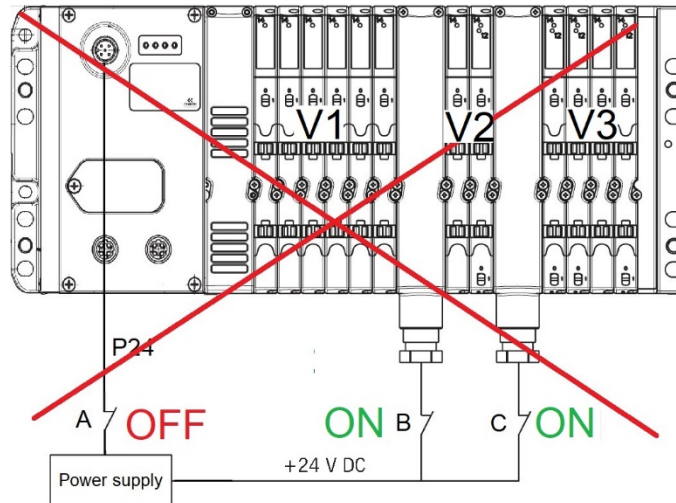

By interrupting the positive pole of an MSA (switch B in OFF position) and maintaining the power supply (P24) of the CPU module (switch A in ON position), the valves positioned between this MSA module and the next one on the valve island will turn off (V2), while those that precede it (V1) and those of any other MSA that follow it from which the + 24V power supply has not been disconnected (V3) will remain on.

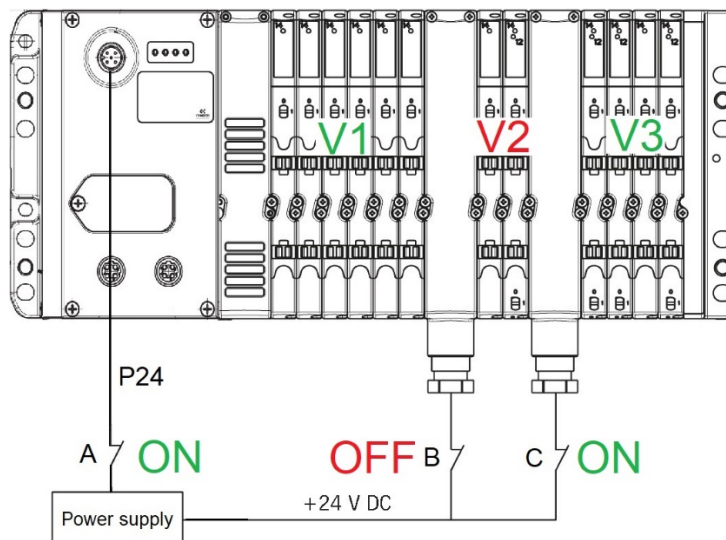

By interrupting the negative pole of all the MSAs and also disconnecting the power supply (P24) from the CPU module, all valves on the island turn off.

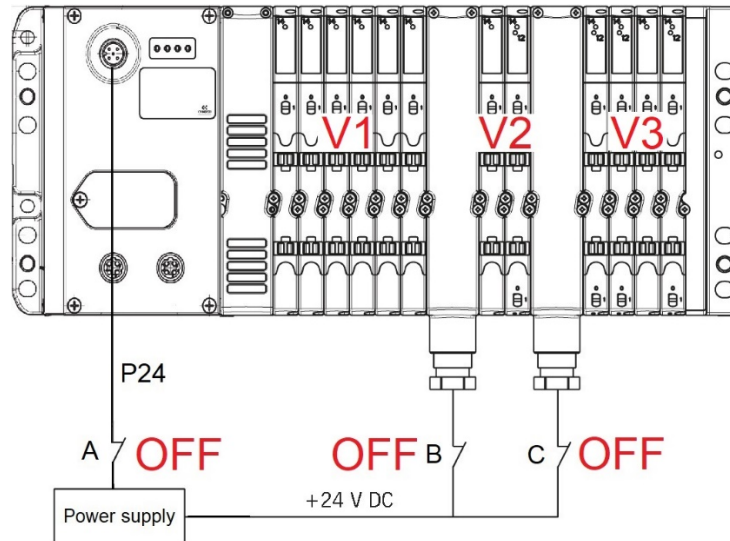

By restoring the connection of the negative pole of the MSA, the valves will immediately resume their normal operation.

14.CXA-25P: Sub-D 25 adapter module



- **Electrical circuit**

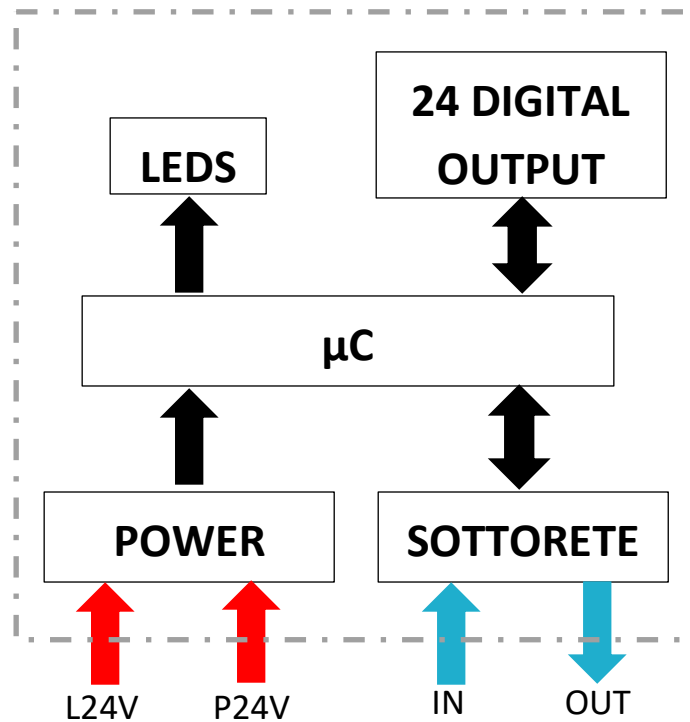

• **Pinout:**

POWER Connector M12A 5 poles male		
Pin	Signal	Description
1	L24V	24Vdc power supply (logic, digital input, analog I/O): connect to the positive pole of the 24Vdc power supply (ref. GND).
2	P24V	24Vdc power supply (digital output): connect to the positive pole of the 24Vdc power supply (ref. GND).
3	GND	Common (reference pin 1 and 2): connect to the negative pole of the 24Vdc power supply (compulsory).
4	EARTH	Earth connection
5	NC	Not connected
Subnet IN connector		
Pin	Signal	Description
1	RD+	Transmit data +
2	TD+	Receive data +
3	RD-	Transmit data -
4	TD-	Receive data -
Subnet OUT connector		
Pin	Signal	Description
1	TD+	Transmit data +
2	RD+	Receive data +
3	TD-	Transmit data -
4	RD-	Receive data -

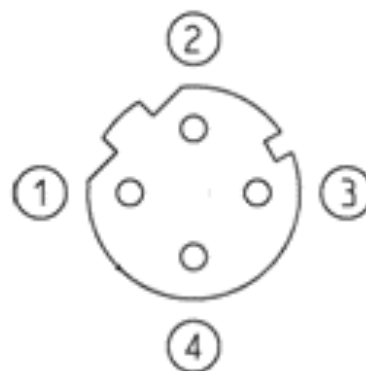
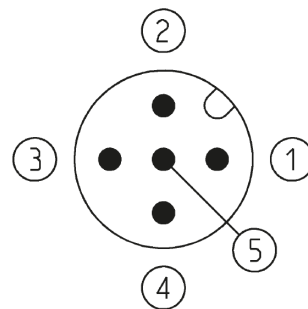

The TD+ signal of subnet IN connector and the RD+ signal of subnet OUT connector are connected together; The TD- signal of subnet IN connector and the RD- signal of subnet OUT connector are connected together.

Don't connect the VCC signal with the GND signal: the card may damage.

Connect the subnet IN connector to a subnet OUT connector of another subnet module; connect the subnet OUT connector to a subnet IN connector of another subnet module or to the subnet tap connector.









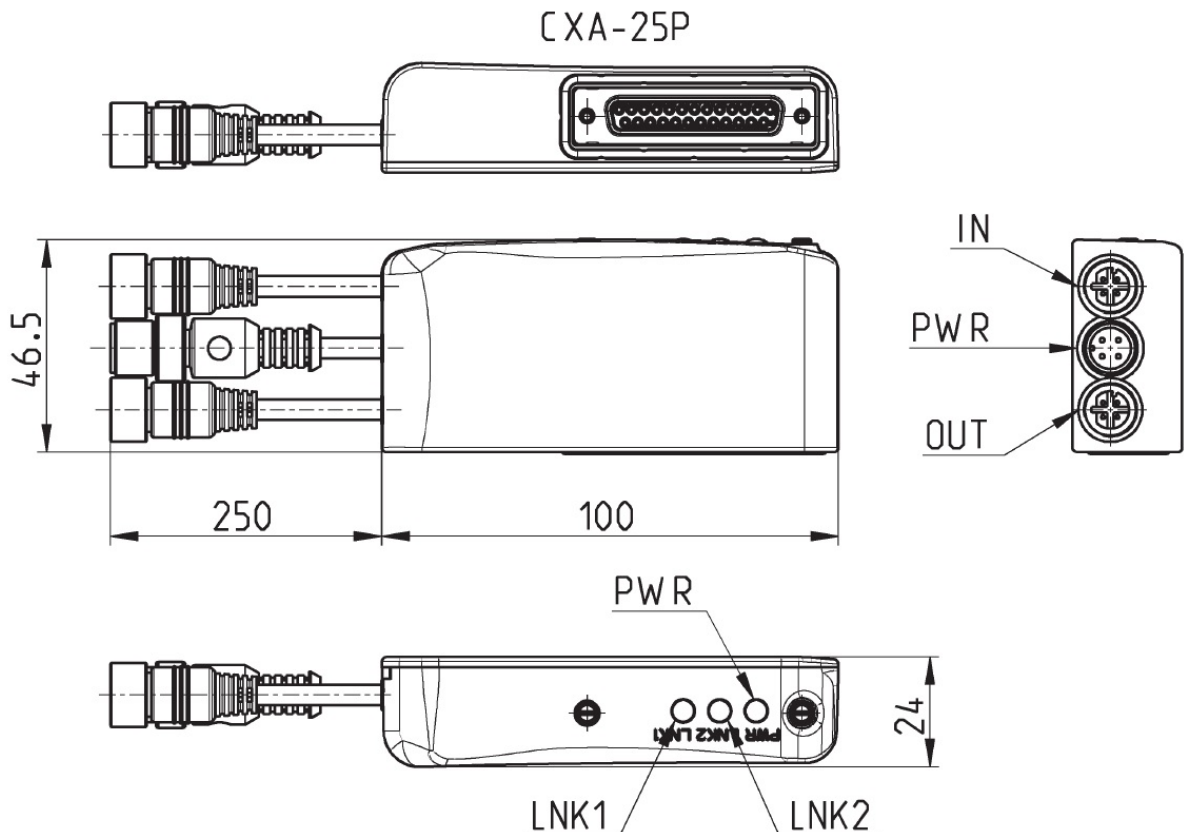

- **Characteristics**

Characteristics

Weight	Approximately 140 gr
Input polarity	PNP
N° of output	24 digital NA (semiconductor) with PWM modulation (Duty Cycle 80%, Frequency 1500HZ)
Electrical connection	Sub-D 25 poles female for the outputs
Overload protection	0,9A every 4 group outputs (1, 2, 3, 4; 5, 6, 7, 8; 9, 10, 11, 12; 13, 14, 15, 16; 17, 18, 19, 20; 21, 22, 23, 24)
Overload protection	24Vdc -15%/+20%
Digital output current consumption	Max 4,5A (limited by resettable fuse)
Logic, digital input, analog I/O current consumption	Max 2,0A (limited by resettable fuse)
Total current consumption	Max 4,8A @ 20°C (not limited by fuse)
Current consumption without load	Approximately 30 mA
Material	Plastic

- **Description**



PWR	Problem		Solution
 Fixed	The module is ON and no subnet communication error are present.		
 Short blink	The output power supply have a value less than 18,5V.		Verify the value of the output power supply.
 Medium blink	The output power supply is not present.		Verify the power connector connections and verify the value of the output power supply.
 Long blink	An output have a short circuit.		Verify the load connected.
 Off	The logic power supply is not present or have a value less than 5V.		Verify the power connector connections and verify the value of the logic power supply.
LNK1	LNK2	Problem	Solution
 Fast blink	 Fast blink	The autoaddressing subnet procedure is working.	Await the conclusion of the procedure.
 Slow blink	 Slow blink	The subnet port IN don't communicate.	Verify if the subnet IN port is correctly connected to the previous block on the subnet. Verify if the module has been recognized by subnet and, if necessary, run the autoaddressing subnet procedure.
 Fixed	 Fixed	No error in the subnet configuration.	

- **Data exchange:** each module, with factory settings, send 24 bits (3 byte) output data. This number of bits may be decreased (up to 0 bit) via the software configurator **CX-Configurator** (for more details on using the configurator and especially about this feature, refer to the manual **“Operation and maintenance instructions – CX Configurator”**).

	Operation and maintenance instructions Camozzi internal bus system	5000004823
		Versione 03

According to the following table, each bits matches with an output, the others 4 bits do not matches with outputs.

It is possible to modify the correspondence bit-output via the software configurator **CX-Configurator** (for more details on using the configurator and especially about this feature, refer to the manual “**Operation and maintenance instructions – CX Configurator**”).

Byte 0							
Bit 7	Bit 6	Bit 5	Bit 4	Bit 3	Bit 2	Bit 1	Bit 0
Out n° 8	Out n° 7	Out n° 6	Out n° 5	Out n° 4	Out n° 3	Out n° 2	Out n° 1
Byte 1							
Bit 7	Bit 6	Bit 5	Bit 4	Bit 3	Bit 2	Bit 1	Bit 0
Out n° 16	Out n° 15	Out n° 14	Out n° 13	Out n° 12	Out n° 11	Out n° 10	Out n° 9
Byte 2							
Bit 7	Bit 6	Bit 5	Bit 4	Bit 3	Bit 2	Bit 1	Bit 0
Out n° 24	Out n° 23	Out n° 22	Out n° 21	Out n° 20	Out n° 19	Out n° 18	Out n° 17

If the module is used with valve island series 3, F and H, for the correspondence bits versus coils see the previous chapters (chapter 11 for series 3, 12 for series F and 13 for series H).

- **Parameters:**

It is possible to modify the following parameters via the software configurator **CX-Configurator** (for more details on using the configurator and especially about this feature, refer to the manual “**Operation and maintenance instructions – CX Configurator**”).

Failsafe: it is possible to set the output value (ON/OFF) in case of communication error. Factory setting: the output value don't change.

15.CXA-37P: Sub-D 37 adapter module



- **Electrical circuit**

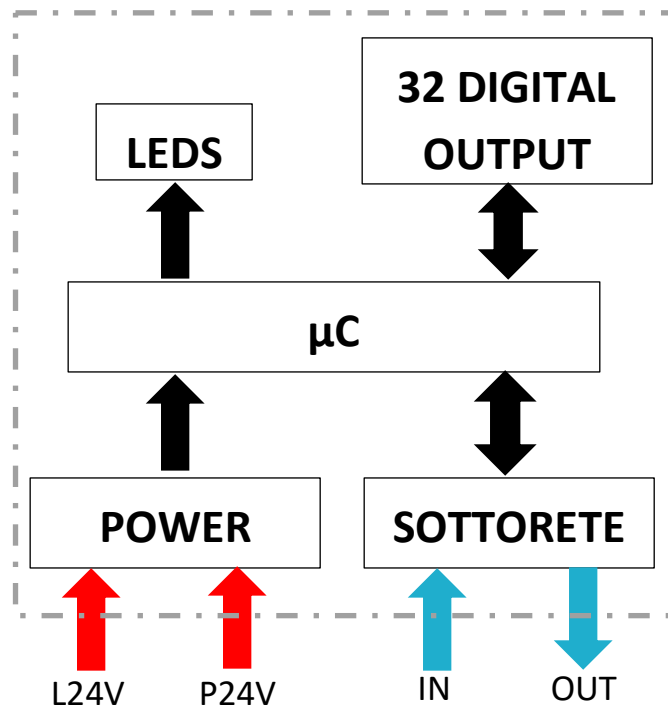

• **Pinout:**

POWER Connector M12A 5 poles male		
Pin	Signal	Description
1	L24V	24Vdc power supply (logic, digital input, analog I/O): connect to the positive pole of the 24Vdc power supply (ref. GND).
2	P24V	24Vdc power supply (digital output): connect to the positive pole of the 24Vdc power supply (ref. GND).
3	GND	Common (reference pin 1 and 2): connect to the negative pole of the 24Vdc power supply (compulsory).
4	EARTH	Earth connection
5	NC	Not connected
Subnet IN connector		
Pin	Signal	Description
1	RD+	Transmit data +
2	TD+	Receive data +
3	RD-	Transmit data -
4	TD-	Receive data -
Subnet OUT connector		
Pin	Signal	Description
1	TD+	Transmit data +
2	RD+	Receive data +
3	TD-	Transmit data -
4	RD-	Receive data -

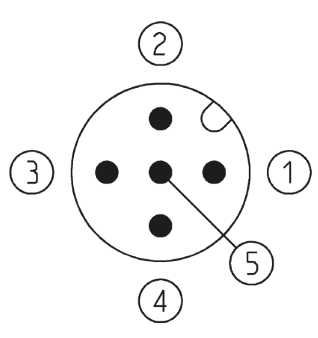
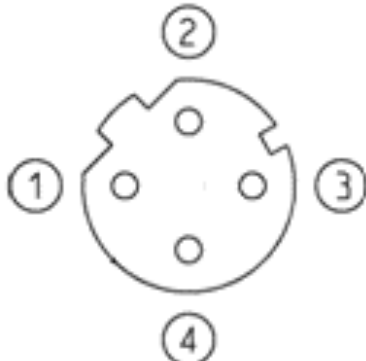
The TD+ signal of subnet IN connector and the RD+ signal of subnet OUT connector are connected together; The TD- signal of subnet IN connector and the RD- signal of subnet OUT connector are connected together.

Don't connect the VCC signal with the GND signal: the card may damage.

Connect the subnet IN connector to a subnet OUT connector of another subnet module; connect the subnet OUT connector to a subnet IN connector of another subnet module or to the subnet tap connector.









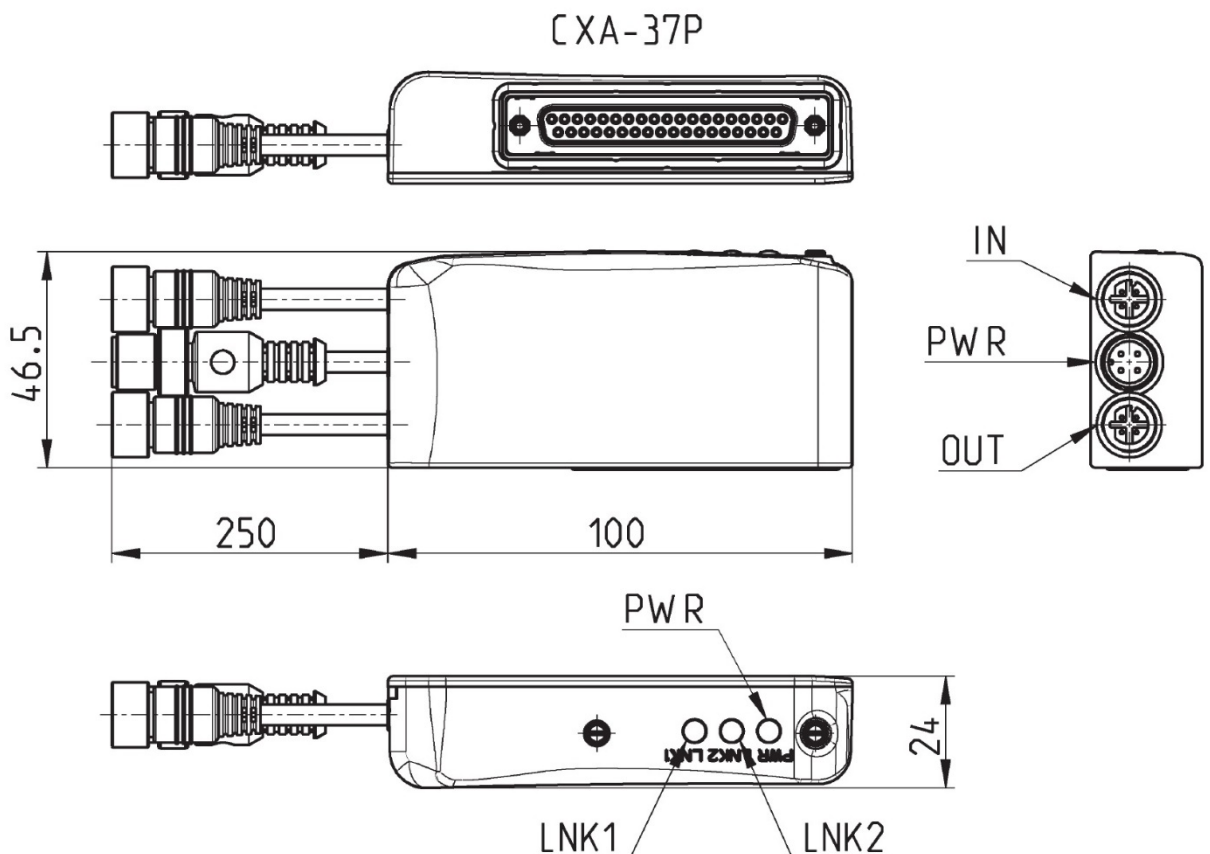

- **Characteristics**

Characteristics

Weight	Approximately 140 gr
Input polarity	PNP
N° of output	32 digital NA (semiconductor) with PWM modulation (Duty Cycle 80%, Frequency 1500HZ)
Electrical connection	Sub-D 25 poles female for the outputs
Overload protection	0,9A every 4 group outputs (1, 2, 3, 4; 5, 6, 7, 8; 9, 10, 11, 12; 13, 14, 15, 16; 17, 18, 19, 20; 21, 22, 23, 24; 25, 26, 27, 28; 29, 30, 31, 32)
Overload protection	24Vdc -15%/+20%
Digital output current consumption	Max 4,5A (limited by resettable fuse)
Logic, digital input, analog I/O current consumption	Max 2,0A (limited by resettable fuse)
Total current consumption	Max 4,8A @ 20°C (not limited by fuse)
Current consumption without load	Approximately 30 mA
Material	Plastic

- **Description**



PWR		Problem		Solution
	Fixed	The module is ON and no subnet communication error are present.		
	Short blink	The output power supply have a value less than 18,5V.		Verify the value of the output power supply.
	Medium blink	The output power supply is not present.		Verify the power connector connections and verify the value of the output power supply.
	Long blink	An output have a short circuit.		Verify the load connected.
	Off	The logic power supply is not present or have a value less than 5V.		Verify the power connector connections and verify the value of the logic power supply.
LNK1	LNK2	Problem		Solution
		The autoaddressing subnet procedure is working.		Await the conclusion of the procedure.
		The subnet port IN don't communicate.		Verify if the subnet IN port is correctly connected to the previous block on the subnet. Verify if the module has been recognized by subnet and, if necessary, run the autoaddressing subnet procedure.
		No error in the subnet configuration.		

- **Data exchange:** each module, with factory settings, send 32 bits (4 byte) output data. This number of bits may be decreased (up to 0 bit) via the software configurator **CX-Configurator** (for more details on using the configurator and especially about this feature, refer to the manual **“Operation and maintenance instructions – CX Configurator”**).

	Operation and maintenance instructions Camozzi internal bus system	5000004823
		Versione 03

According to the following table, each bits matches with an output, the others 4 bits do not matches with outputs.

It is possible to modify the correspondence bit-output via the software configurator **CX-Configurator** (for more details on using the configurator and especially about this feature, refer to the manual “**Operation and maintenance instructions – CX Configurator**”):

Byte 0							
Bit 7	Bit 6	Bit 5	Bit 4	Bit 3	Bit 2	Bit 1	Bit 0
Out n° 8	Out n° 7	Out n° 6	Out n° 5	Out n° 4	Out n° 3	Out n° 2	Out n° 1
Byte 1							
Bit 7	Bit 6	Bit 5	Bit 4	Bit 3	Bit 2	Bit 1	Bit 0
Out n° 16	Out n° 15	Out n° 14	Out n° 13	Out n° 12	Out n° 11	Out n° 10	Out n° 9
Byte 2							
Bit 7	Bit 6	Bit 5	Bit 4	Bit 3	Bit 2	Bit 1	Bit 0
Out n° 24	Out n° 23	Out n° 22	Out n° 21	Out n° 20	Out n° 19	Out n° 18	Out n° 17
Byte 3							
Bit 7	Bit 6	Bit 5	Bit 4	Bit 3	Bit 2	Bit 1	Bit 0
Out n° 32	Out n° 31	Out n° 30	Out n° 29	Out n° 28	Out n° 27	Out n° 26	Out n° 25

If the module is used with valve island series 3, F and H, for the correspondence bits versus coils see the previous chapters (chapter 11 for series 3, 12 for series F and 13 for series H).

- **Parameters:**

It is possible to modify the following parameters via the software configurator **CX-Configurator** (for more details on using the configurator and especially about this feature, refer to the manual “**Operation and maintenance instructions – CX Configurator**”).

Failsafe: it is possible to set the output value (ON/OFF) in case of communication error. Factory setting: the output value don't change.

16.CX99-0-0: Expansion subnet module



- Electrical circuit

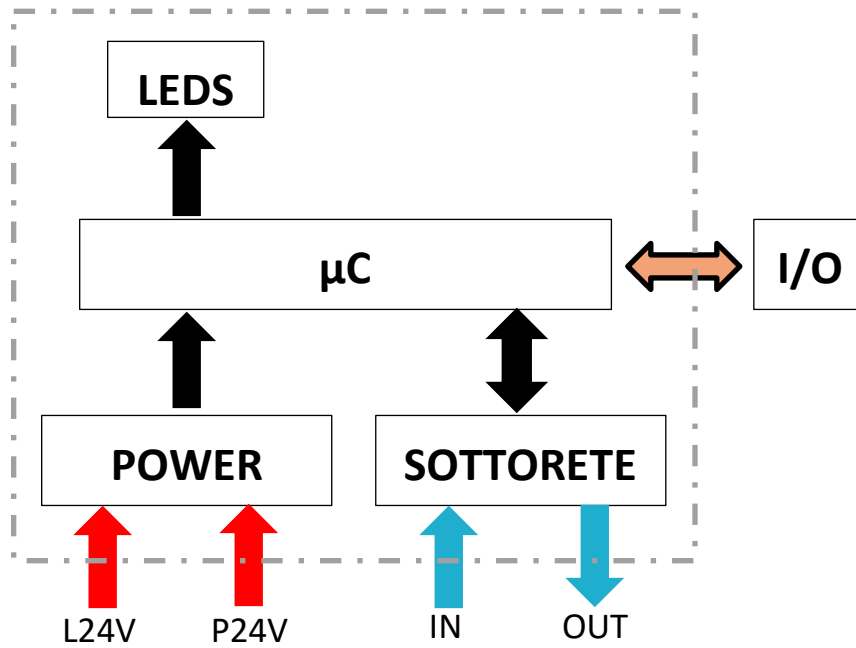

• **Pinout:**

POWER Connector M12A 5 poles male		
Pin	Signal	Description
1	L24V	24Vdc power supply (logic, digital input, analog I/O): connect to the positive pole of the 24Vdc power supply (ref. GND).
2	P24V	24Vdc power supply (digital output): connect to the positive pole of the 24Vdc power supply (ref. GND).
3	GND	Common (reference pin 1 and 2): connect to the negative pole of the 24Vdc power supply (compulsory).
4	EARTH	Earth connection
5	NC	Not connected
Subnet IN connector		
Pin	Signal	Description
1	RD+	Transmit data +
2	TD+	Receive data +
3	RD-	Transmit data -
4	TD-	Receive data -
Subnet OUT connector		
Pin	Signal	Description
1	TD+	Transmit data +
2	RD+	Receive data +
3	TD-	Transmit data -
4	RD-	Receive data -

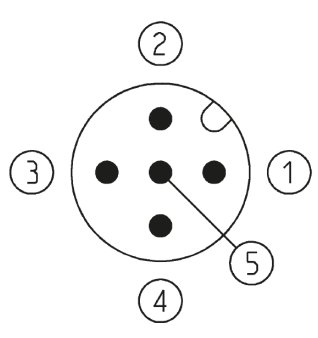
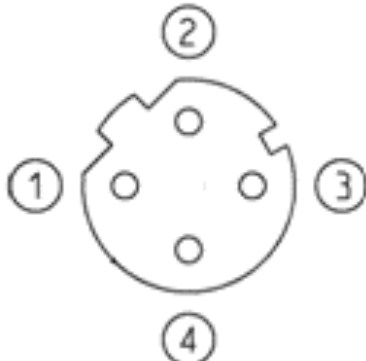
The TD+ signal of subnet IN connector and the RD+ signal of subnet OUT connector are connected together; The TD- signal of subnet IN connector and the RD- signal of subnet OUT connector are connected together.

Don't connect the VCC signal with the GND signal: the card may damage.

Connect the subnet IN connector to a subnet OUT connector of another subnet module; connect the subnet OUT connector to a subnet IN connector of another subnet module or to the subnet tap connector.

- Caratteristiche







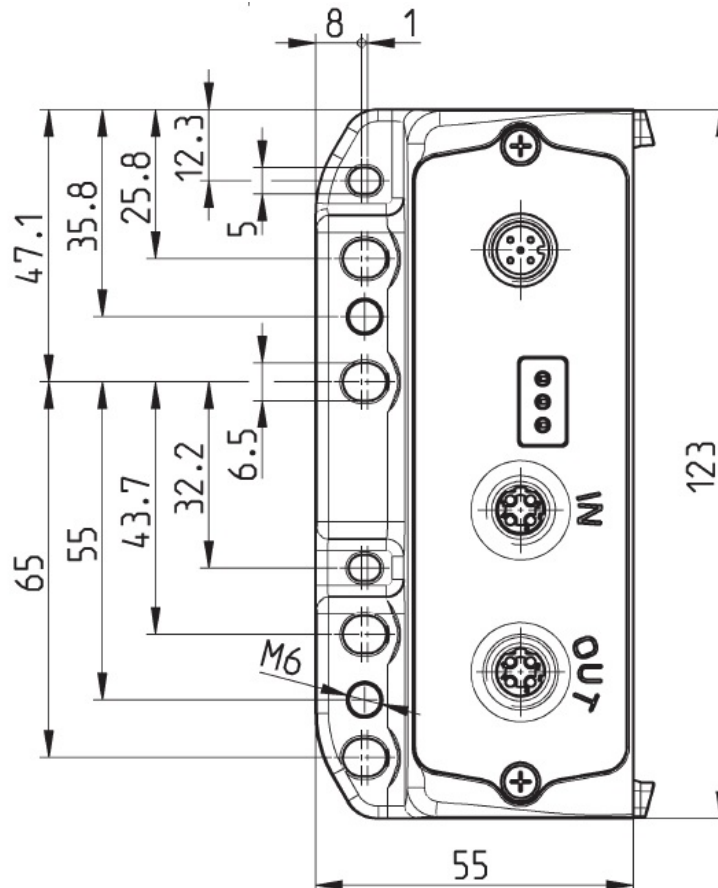



Caratteristiche

Fixing	By screw or DIN rail
Dimensions	L = 123 mm; W = 55 mm
Weight	Approximately 260 gr
Electrical connection	M12
Electrical power supply	24Vdc -15%/+20%
Digital Output Current consumption	Max 4,5A (limited by resettable fuse)
Logic, Digital Input and Analog I/O Current consumption	Max 2,0A (limited by resettable fuse)
Total Current consumption	Max 4,8A @ 20°C (not limited by fuse)
Output maximum number	1024
Input maximum number	1024
Current consumption without load	Approximately 25 mA
Material	Alluminium

- Fixang



- The device can be connected to DIN rails using the relative elements PCF-E520 fitted on the rear of the body.
- The component can be directly fixed to a support using the 8 holes (of which 2 threaded M6) present on the side of the body
- **Signalling LED**

PWR		Problem		Solution
	Fixed	The module is ON and no subnet communication error are present.		
	Short blink	The output power supply have a value less than 18,5V.		Verify the value of the output power supply.
	Medium blink	The output power supply is not present.		Verify the power connector connections and verify the value of the output power supply.
	Long blink	An output have a short circuit.		Verify the load connected.
LNK1	LNK2	Problem		Solution
		The autoaddressing subnet procedure is working.		Await the conclusion of the procedure.
		The subnet port IN don't communicate.		Verify if the subnet IN port is correctly connected to the previous block on the subnet. Verify if the module has been recognized by subnet and, if necessary, run the autoaddressing subnet procedure.
		No error in the subnet configuration.		

17.ME3-0000-SL: Initial subnet module



- Electrical circuit

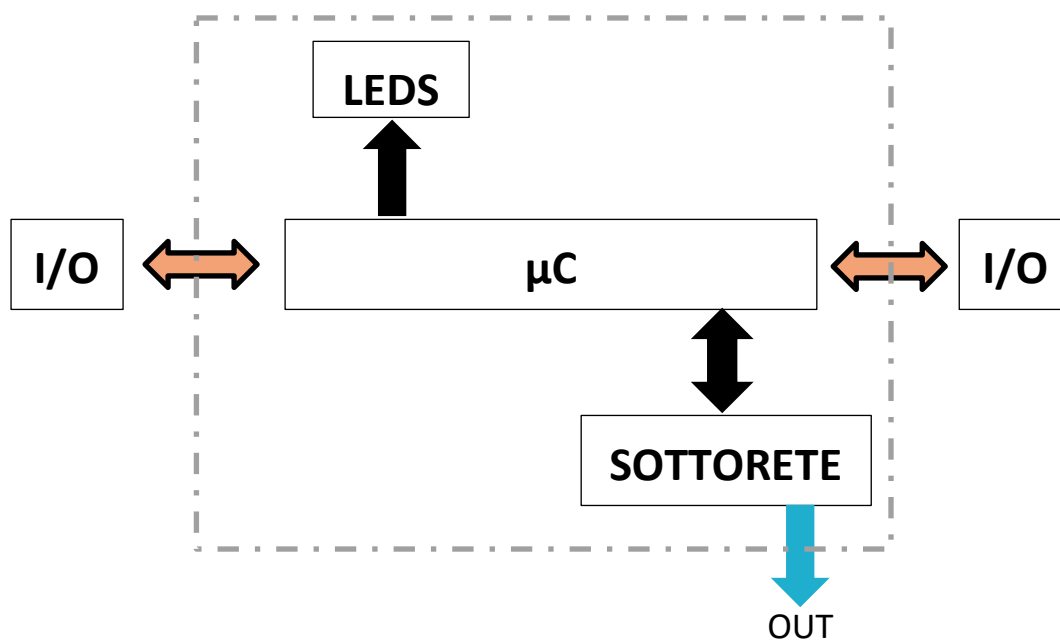

• **Pinout:**

Subnet OUT connector		
Pin	Signal	Description
1	TD+	Transmit data +
2	RD+	Receive data +
3	TD-	Transmit data -
4	RD-	Receive data -

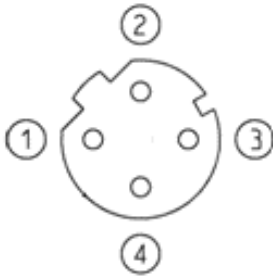

Collegare il connettore OUT della sottorete a un connettore IN della sottorete di un altro modulo oppure alla resistenza di terminazione della sottorete.

Connect the subnet OUT connector to a subnet IN connector of another subnet module or to the subnet tap conn

• **Characteristics**

Characteristics

Weight Approximately 110 gr



Electrical connection M12D 4 poles female

Dimensions L = 122 mm; W = 26 mm

Current consumption without load Approximately 20 mA

Material Alluminium

• **Signalling LED**

LNK	Problem	Solution
 Fast blink	The autoaddressing subnet procedure is working.	Await the conclusion of the procedure.
 Slow blink	The subnet port IN don't communicate.	Verify if the subnet IN port is correctly connected to the previous block on the subnet. Verify if the module has been recognized by subnet and, if necessary, run the autoaddressing subnet procedure.
 Fixed	No error in the subnet configuration.	

	Operation and maintenance instructions Camozzi internal bus system	5000004823
		Versione 03

18. Configurations

All modules “I/O” listed below (digitals, analogs, interface) and the module “Initial subnet”, could be connected only on the right of one “CPU” or “expansion” module, without constraints about order and number but is required to respect the maximum load admitted, and this group of modules produce a block in the Camozzi subnet.

In every block is possible to connect only one from the type modules “Valve island direct interface”. The “adapter” modules are similar to a block in the Camozzi network.

Connecting to each other's more blocks (by using Ethernet cable M12 preassembled provided by Camozzi) it is possible to create a subnet that communicate with the master (PLC) via the alone CPU module in the subnet: all Camozzi subnet are recognized from the master as only one slave of the communication system.

It is possible to connect the blocks to each other's using the IN e OUT port of the “Initial subnet”, “Expansion subnet” and “Adapter”.

The branches in the subnet Camozzi start from the OUT port of a “Initial subnet” module and end with a tap (code CS-SU04H0) connected to the OUT port of an “Expansion subnet” or “Adapter” module. Is mandatory to connect the OUT port to the IN port of the following module or to connect the tap if this is the last module in the branch.

Using this system, very flexible, it is possible to realize a lot of different configurations. We list some of these below:

LINEAR

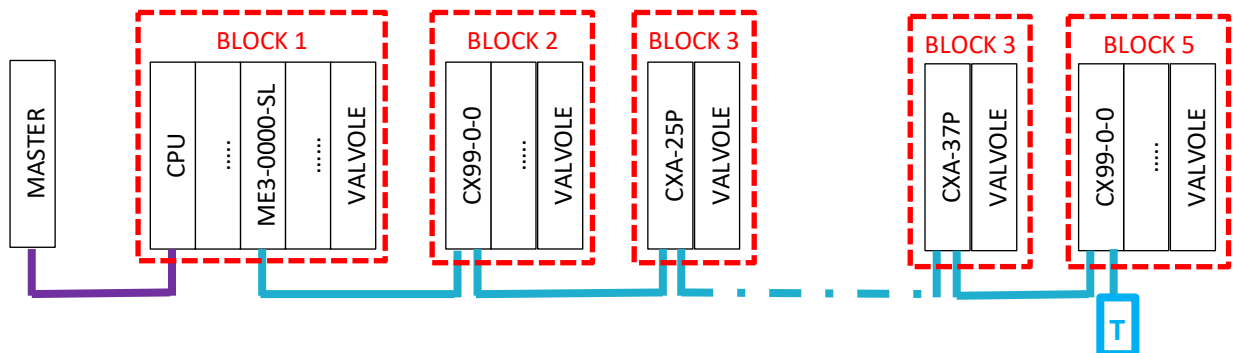

This configuration has only one “Initial subnet” module added in the block with the “CPU” module. The OUT port of this “Initial subnet” is linked to the IN port of the following block. The connection is repeated until the last block, where in the OUT port is connected the tap. More blocks (highlighted by red dashed square) and only one branch compose this configuration.

STAR

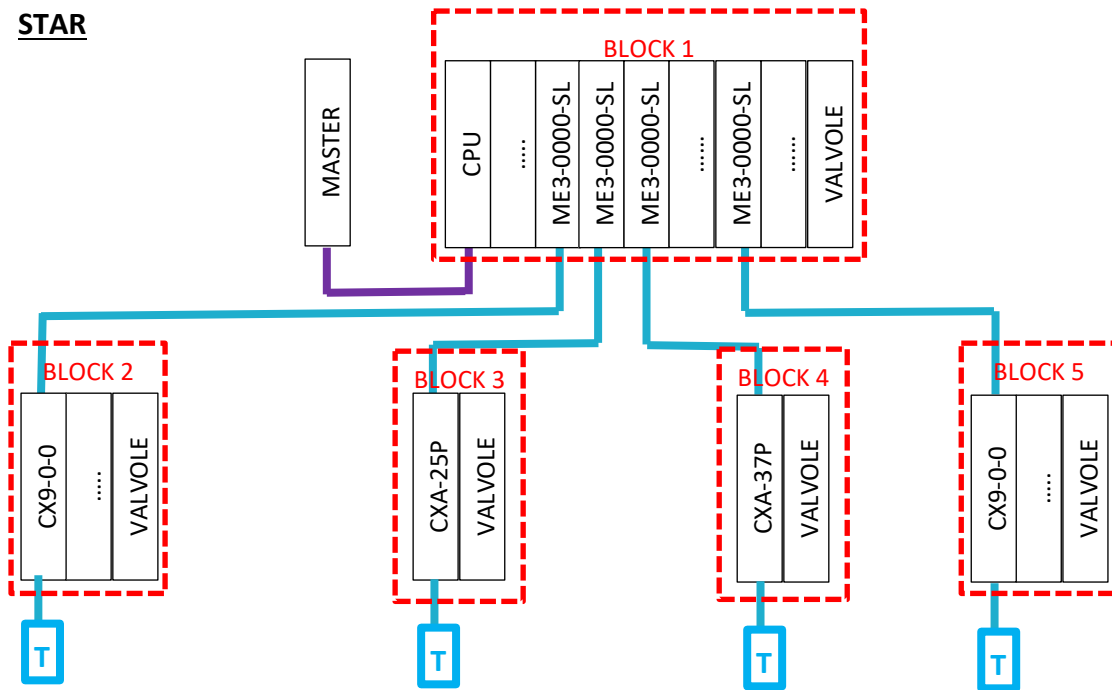

This configuration has more “Initial subnet” module added in the block with the “CPU” module. Every OUT port of these “Initial subnet” is linked to the IN port of the different block, where in the OUT port is connected the tap.

More blocks (highlighted by red dashed square) and more branches (with only one block) compose this configuration.

TREE

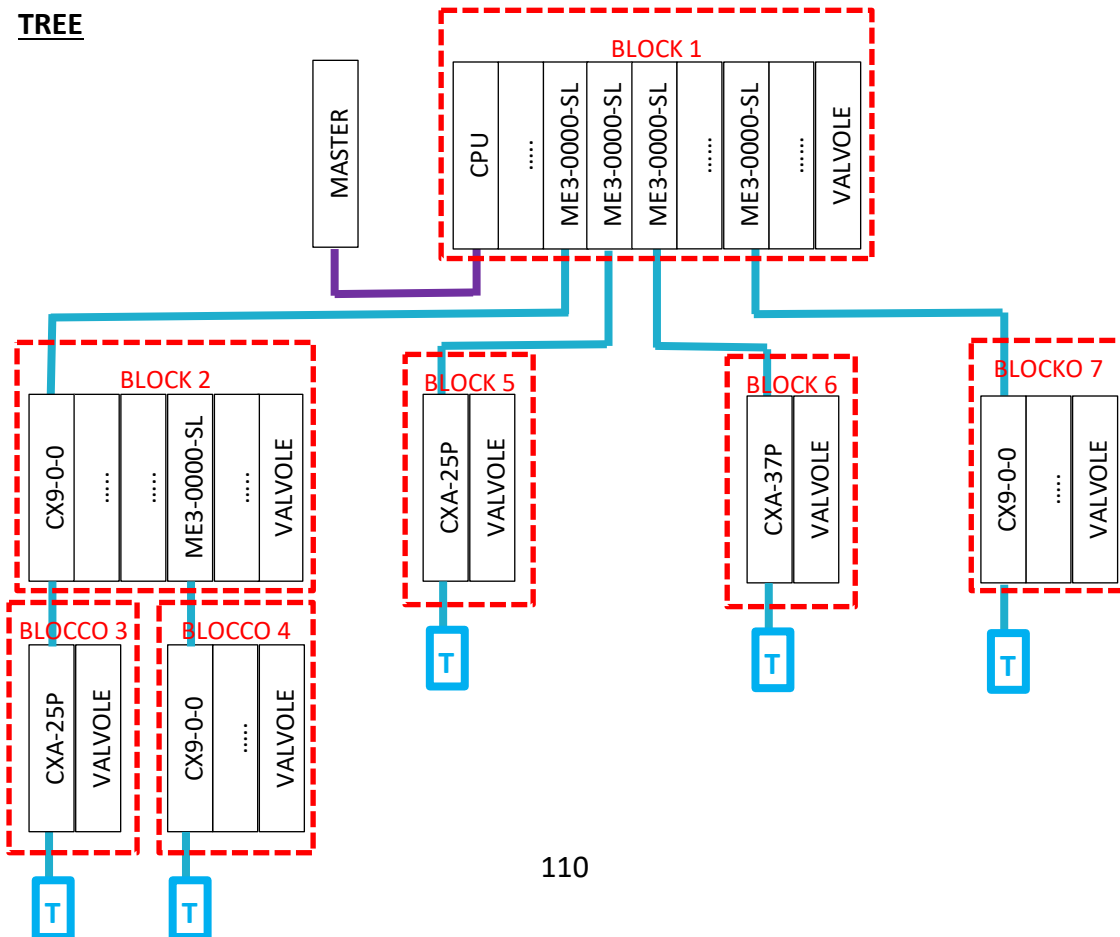

	Operation and maintenance instructions Camozzi internal bus system	5000004823
		Versione 03

This configuration has one or more “Initial subnet” module added in the block 1 with the “CPU” module and one or more “Initial subnet” module added in the blocks with the “Expansion” module. Every OUT port of these “Initial subnet” is linked to the IN port of another block, where in the OUT port is connected another block or the tap.

More blocks (highlighted by red dashed square) and more branches (with more than one block) compose this configuration. The branch length and the number of block in the branch are measured from the “Initial subnet” module added in the block 1 to the associated tap.

19. Topological limits

The subnet Camozzi must to comply with some topological rules in order to properly work. By the flexibility of the subnet is difficult to define detailed rules, but if the subnet is comply with the following rules the subnet will works properly; in order to evaluate topology that aren't comply with this rules contact the Camozzi service.

- Each branch can have up to 8 blocks.
- The maximum branch length is 100 meters.
- Each Camozzi subnet can have up to 6 branches.

20. Addressing

Every module in the Camozzi subnet require an address in order to manage it. It's possible to assign an address with an automatic auto addressing procedure.

The addressing will be sequential in order as the subnet are connected. In detail, the addresses are assigned sequentially from left to right inside the block, from to the first block to the last in the first branch.

When all blocks in the first branch are processed, the procedure assign the address to the modules in the next branch of the subnet.

The input and output are mapped in the master memory sequentially based the address assigned and use several bits based the modules features.

ATTENTION: the subnet auto addressing procedure reassign the address to all modules in the subnet and so modify the sequence of input and output. The procedure doesn't modify the parameters assigned to the modules. Pay attention and use carefully this procedure.

The steps in order to perform the auto addressing procedure are listed:

- Turn-off the module; check if all modules of Camozzi subnet are properly connected and powered and if the subnet terminator are connected; remove the transparent cover from the CPU module and press the Reset button.

Reset button



- Hold on the Reset button, power on the CPU module. Wait some seconds and release the Reset button
- In order to activate the auto addressing routine, press the Reset button.
The yellow LNK leds on the modules “Initial Subnet”, “Expansion” and “Adapter” start to blink quickly and became fixed on when the routine finished.
- It’s possible to verify if all module in the Camozzi subnet are recognized and check the addresses assigned via the software configurator **CX-Configurator** (for more details on using the configurator and especially about this feature, refer to the manual “**Operation and maintenance instructions – CX Configurator**”).
- After reassemble the transparent cover to the CPU module in order to obtain the right IP protection degree.
- It’s also possible to perform the auto addressing procedure via the software configurator **CX-Configurator** (for more details on using the configurator and especially about this feature, refer to the manual “**Operation and maintenance instructions – CX Configurator**”).

21.Diagnostic

In addition to error’s signaling with led. The subnet Camozzi provide to the master at least 13 diagnostic bytes. These bytes, if mapped in the master memory, are automatically added at the end of input bytes reserved for the input modules. The 13 (or more) diagnostic bytes uses a part of 128 bytes managed by the subnet. It’s possible don’t send these bytes to the master (in this case is necessary to reserve only the memory space for the input modules in the subnet), send these byte but don’t manage them or send these byte and manage them (in these cases is necessary to reserve the memory space for the input modules in the subnet added to the diagnostic bytes space).

Below is the meaning of the various diagnostic bits.

BYTE 0

bit 0 (modules presence in the Camozzi subnet)

= 0: at least one of addressed modules is absent (disconnected or/and turn off)

= 1: all addressed modules are present (connected and turn on)

bit 1 (modules communication in the Camozzi subnet)

	Operation and maintenance instructions Camozzi internal bus system	5000004823
		Versione 03

= 0: at least one of addressed modules have communication problems

= 1: all addressed modules communicate properly

bit 2 (modules errors in the Camozzi subnet)

= 0: at least one of addressed modules generates an error

= 1: no one of addressed modules generates an error

Bit 3, 4, 5, 6, 7: reserved (= 0)

The following diagnostic bytes are divided into 3 different group with the same dimension, where each bit represents a single module according to the assigned address. The minimum dimension of these 3 groups is 4 bytes, so it's possible to have at most 32 modules in the subnet. If the subnet has more than 32 modules, the number of diagnostic bytes is increased: every byte added to the 3 groups represent 8 further modules.

The bits in the byte 1 are the summary of the corresponding bytes group: if at least 1 bit of the group have value 1 also the corresponding bit in the byte 1 will have value 1, if all bits in the group have value 0 also the corresponding bit in the byte 1 will have value 0.

FIRST GROUP: (modules presence in the Camozzi subnet) each bit indicates the presence (bit = 1) or the absence (bit = 0) of the associated module.

SECOND GROUP: (modules communication in the Camozzi subnet) each bit indicates the presence (bit = 1) or the absence (bit = 0) of communication errors of associated module.

THIRD GROUP: (modules errors in the Camozzi subnet) each bit indicates the presence (bit = 1) or the absence (bit = 0) of error in the associated module.

	Operation and maintenance instructions Camozzi internal bus system	5000004823
		Versione 03

22. Use

- Ensure that the electrical power supply and all other operating conditions remain within the admissible values.
- The product may only be used in observance of the specifications provided; if these requirements are not met, the product may only be used on authorisation by Camozzi.
- Observe the specifications on the identification data plate.

23. Limitations on use

- Never exceed the technical specifications stated in the paragraph "General characteristics" and the Camozzi general catalogue.
- Do not install the product in environments where the air itself may generate hazards.
- With the exception of specific intended applications, do not use the product in environments where there is the risk of direct contact with corrosive gas, chemical products, salt water, water or steam.

24. Maintenance

- If performed incorrectly, maintenance may impair efficient operation of the product and harm persons in the vicinity.
- Check all conditions to prevent the inadvertent release of parts, and disconnect the power supply to enable the discharge of residual pressure from the system before performing work.
- Check whether it is possible to have the product serviced at a technical assistance centre.
- Never disassemble units when electrically powered.
- Shut off electric supplies before maintenance.
- Always remove accessories before maintenance.
- Always wear the correct personal protective equipment as envisaged by local authorities and in compliance with current legislation.
- In the event of maintenance, replacement of worn parts, use exclusively the original Camozzi kits and ensure that operations are only performed by specialised and authorised personnel. Otherwise product approval will be rendered invalid.

25. Environmental notes

- At the end of the product's life cycle, separate the relative materials to enable recycling.
- Observe all current standards in the country of use governing waste disposal.
- The product and relative parts all comply with the standards ROHS and REACH.

	Operation and maintenance instructions	5000004823
	Camozzi internal bus system	Versione 03

26.Contatti

Camozzi spa

Società Unipersonale

Via Eritrea, 20/I

25126 Brescia - Italy

Tel. +39 030 37921

info@camozzi.com

www.camozzi.com

Product Certification

National and International Directives, Regulations and Standards

productcertification@camozzi.com

Technical assistance

Technical information

Product information

Special products

Tel.+39 030 3792790

service@camozzi.com